



WILDERNESS LAKE

P R E S E R V E

Advanced Meeting Package

Regular Meeting

Wednesday

July 1, 2026

9:30 a.m.

Location:

*The Preserve at Wilderness Lake,
located in the Activities Center at
21320 Wilderness Lake Boulevard,
Land O' Lakes, FL 34637*

*Note: The Advanced Meeting Package is a working document and thus all materials are considered **DRAFTS** prior to presentation and Board acceptance, approval, or adoption.*

The Preserve at Wilderness Lake Community Development District

250 International Parkway, Suite 208
Lake Mary, FL 32746
321-263-0132

Board of Supervisors
The Preserve at Wilderness Lake Community Development District

Dear Board Members:

The Regular Meeting of the Board of Supervisors of The Preserve at Wilderness Lake Community Development District is scheduled for **Wednesday, July 1, 2026, at 9:30 a.m.** at **The Preserve at Wilderness Lake, located in the Activities Center at 21320 Wilderness Lake Boulevard, Land O' Lakes, FL 34637.**

An advanced copy of the agenda for the meeting is attached along with associated documentation for your review and consideration. Any additional support material will be distributed at the meeting.

Should you have any questions regarding the agenda, please contact me at (321) 263-0132 X-285 or tdobson@vestapropertyservices.com. We look forward to seeing you at the meeting.

Sincerely,

Tish Dobson

Tish Dobson
District Manager



WILDERNESS LAKE

P R E S E R V E

Meeting Date: Wednesday, July 1, 2026 Call-in Number: +1 (929) 205-6099
Time: 9:30 AM Meeting ID: 913 989 9080#
Location: The Preserve at Wilderness Passcode: 842235
Lake Lodge, 21320 Link: [Zoom Link](#)
Wilderness Lake Blvd., Land
O' Lakes, FL 34637

Revised Agenda

- I. Call to Order/Roll Call**
- II. Pledge of Allegiance**
- III. Audience Comments** – *(limited to 3 minutes per individual for agenda items)*
- IV. Presentation of Proof of Publication(s)** [Exhibit 1](#)
[Pg. 7](#)
- V. Supervisor Comments**
- VI. Staff Reports**
 - A. Aquatic Services
 - 1. GHS Environmental Report [Exhibit 2](#)
[Pgs. 9-10](#)
 - B. District Engineer [Exhibit 3](#)
[Pgs. 12-13](#)
 - C. District Counsel
 - D. Community & District Manager, & Field Operations Report [Exhibit 4](#)
[Pgs. 15-62](#)
 - E. Landscaping & Irrigation
 - 2. **RedTree Report – June Irrigation Report** [Exhibit 5](#)
[Pgs. 64-142](#)
 - 3. RedTree Landscape Inspection Report – June 2026 [Exhibit 6](#)
[Pgs. 145-157](#)
 - 4. RedTree Proposals (if any)

VII. Consent Agenda

- A. Consideration for Approval – The Minutes of the Board of Supervisors Regular Meeting Held on June 10, 2026 [Exhibit 7](#)
[Pgs. 159-163](#)
- B. Consideration for Acceptance – The May 2026 Unaudited Financial Statements [Exhibit 8](#)
[Pgs. 165-211](#)
- C. Consideration for Acceptance – The May 2026 Operations & Maintenance Expenditures [Exhibit 9](#)
[Pgs. 213-443](#)
- D. Ratification of Cooper Pools Proposals [Exhibit 10](#)
[Pgs. 445-446](#)
 - 1. Quote #1039 - \$302.22
 - 2. Quote #1054 - \$3,050.00

VIII. Business Items

- A. Consideration & Adoption of **Resolution 2026-05**, Designating Officers [Exhibit 11](#)
[Pg. 448](#)
- B. Consideration & Adoption of **Resolution 2026-06**, Designating Signatories [Exhibit 12](#)
[Pgs. 450-451](#)
- C. CDD/HOA Shared Irrigation Agreement Communication [Exhibit 13](#)
[Pgs. 453-454](#)
- D. Consideration of Specialty Surfaces Rubber Repairs Proposal - \$1,350.00 [Exhibit 14](#)
[Pg. 456](#)
- E. Consideration of Oakhurst/Woodsmere Park Shade Structure Replacement Proposal Options [Exhibit 15](#)
 - 1. ARC - \$53,815.00 [Exhibit 15A](#)
[Pgs. 459-466](#)
 - 2. Project Innovations Inc. - \$50,500.00 [Exhibit 15B](#)
[Pgs. 468-472](#)
- F. Consideration of Site Masters Oakhurst Pavilion Slab Removal & Replacement Proposal - \$6,520.00 [Exhibit 16](#)
[Pg. 474](#)
- G. **Consideration of Basketball & Tennis Court Repairs & Repainting Proposal Options** [Exhibit 17](#)
 - 1. **Coastal Courts (Basketball) - \$6,343.00** [Exhibit 17A](#)
[Pgs. 477-479](#)
 - 2. **Florida Courts (Basketball) - \$4,800.00** [Exhibit 17B](#)
[Pgs. 481-483](#)
 - 3. **FDC (Both) - \$22,970.00** [Exhibit 17C](#)
[Pgs. 485-486](#)
 - 4. **Coastal Courts (Tennis) - \$19,736.00** [Exhibit 17D](#)
[Pgs. 488-491](#)
 - 5. **Florida Courts (Tennis) - \$46,000.00** [Exhibit 17E](#)
[Pgs. 493-495](#)

IX. Supervisors' Requests

X. Audience Comments – New Business - *(limited to 3 minutes per individual for non-agenda items)*

XI. Next Meeting Quorum Check: August 5 at 6:30 PM + Budget Public Hearing

Beth Edwards	<input type="checkbox"/> IN PERSON	<input type="checkbox"/> REMOTE	<input type="checkbox"/> NO
Agnieszka Fisher	<input type="checkbox"/> IN PERSON	<input type="checkbox"/> REMOTE	<input type="checkbox"/> NO
John Staples	<input type="checkbox"/> IN PERSON	<input type="checkbox"/> REMOTE	<input type="checkbox"/> NO
Holly Ruhlig	<input type="checkbox"/> IN PERSON	<input type="checkbox"/> REMOTE	<input type="checkbox"/> NO
Heather Hepner	<input type="checkbox"/> IN PERSON	<input type="checkbox"/> REMOTE	<input type="checkbox"/> NO

XII. Adjournment

EXHIBIT 1

**THE PRESERVE AT WILDERNESS LAKE
COMMUNITY DEVELOPMENT DISTRICT
NOTICE OF BOARD OF SUPERVISORS REGULAR MEETING**

Notice is hereby given that a regular meeting of the Board of Supervisors of The Preserve at Wilderness Lake Community Development District (the "District") will be held on Wednesday, July 1, 2026, at 9:30 a.m. at The Preserve at Wilderness Lake Lodge, located at 21320 Wilderness Lake Boulevard, Land O' Lakes, FL 34637. The purpose of the meeting is to discuss any topics presented to the board for consideration.

Copies of the agenda may be obtained from the District Manager, Vesta District Services, 250 International Parkway, Suite 208, Lake Mary, Florida 32746, Telephone (321) 263-0132, Ext. 285.

The meeting is open to the public and will be conducted in accordance with the provisions of Florida law for community development districts. The meeting may be continued in progress without additional notice of a date, time, and place to be specified on the record at the meeting. There may be occasions when Staff and/or Supervisors may participate by speaker telephone.

Pursuant to provisions of the Americans with Disabilities Act, any person requiring special accommodations to participate in the meeting is asked to advise the District Manager's office at least forty-eight (48) hours before the meeting by contacting the District Manager at (321) 263-0132, Ext. 285. If you are hearing or speech impaired, please contact the Florida Relay Service at 711, for assistance in contacting the District Manager's office.

A person who decides to appeal any decision made at the meeting, with respect to any matter considered at the meeting, is advised that a record of the proceedings is needed and that accordingly, the person may need to ensure that a verbatim record of the proceedings is made, including the testimony and evidence upon which the appeal is to be based.

The Preserve at Wilderness Lake Community Development District
Tish Dobson, District Manager
(321) 263-0132, Ext. 285
June 24, 2026

93710

EXHIBIT 2



GHS Environmental

PO Box 55802

St. Petersburg, FL 33732-5802

727-667-6786

June 23, 2026

The Preserve at Wilderness Lake CDD
c/o Mrs. Tish Dobson
21320 Wilderness Lake Boulevard
Land O' Lakes, Florida 34637

**Re: The Preserve at Wilderness Lake Community Development District (CDD)
June 2026 Summary Report**

Dear Mrs. Dobson,

GHS Environmental (GHS) submits this report to summarize the work completed during June 2026 at the Wilderness Lake Preserve (WLP) community in Land O' Lakes, Florida.

Service Dates: June 4, 11, 12 and 18

Summary of Monthly Objectives/Goals Achieved:

1. Performed monthly inspections and maintenance of vegetation/algae in stormwater ponds.
2. Removed trash from stormwater ponds.
3. Reviewed DM Meeting Notes and Action Items prepared by T. Dobson.
4. Field checked control structures CS-P1 and CS-P2 located in Wetland P to ensure there are no blockages.
5. Treated vegetation in the 5 feet clearance zone behind Pond 39 weir.
6. Coordination with T. Dobson on the status of the maintenance areas and finishing the Brazilian pepper area on Maintenance Area No. 6.
7. Applied EutroSorb in Pond No. 24 to remove phosphorus from the water column to help with algae control.
8. Phone and email correspondence with WLP staff.
9. Prepared and submitted monthly summary report.

We appreciate the opportunity to assist you with this project. Please call us on (727) 432-2820 with any questions or if you need more information.

Sincerely,

GHS Environmental

A handwritten signature in black ink, appearing to read 'Chuck Burnite'.

Chuck Burnite
Senior Environmental Scientist

THE PRESERVE AT WILDERNESS LAKES CDD

Map of Stormwater Ponds, Natural Wetlands and Wood Line Trimming Areas

Legend

- Stormwater Ponds
- Natural Wetland Systems
- Natural Lake (Open Water)
- Property Boundary
- Cul-De-Sac Maintenance
- Weir
- Bubbler Box
- Control Structure
- Drainage Flow

Wood Line Trimming Areas

- Maintenance Area No. 1
- Maintenance Area No. 2
- Maintenance Area No. 3
- Maintenance Area No. 4
- Maintenance Area No. 5
- Maintenance Area No. 6
- Maintenance Area No. 7
- Maintenance Area No. 8
- Maintenance Area No. 9
- Maintenance Area No. 10
- Maintenance Area No. 11
- Maintenance Area No. 12

Note: Natural Lake "E" was previously identified as Stormwater Pond No. 23 on maps prepared by others. Since this area is natural, it has been moved into the wetland lettering system. There is no Stormwater Pond No. 23.

Date: September 18, 2020



Not to Scale



GHS Environmental
 PO Box 55802
 St. Petersburg, FL 33732-5582
 Phone: 727-432-2820
 Chuck@GHSEnvironmental.com
 www.GHSEnvironmental.com

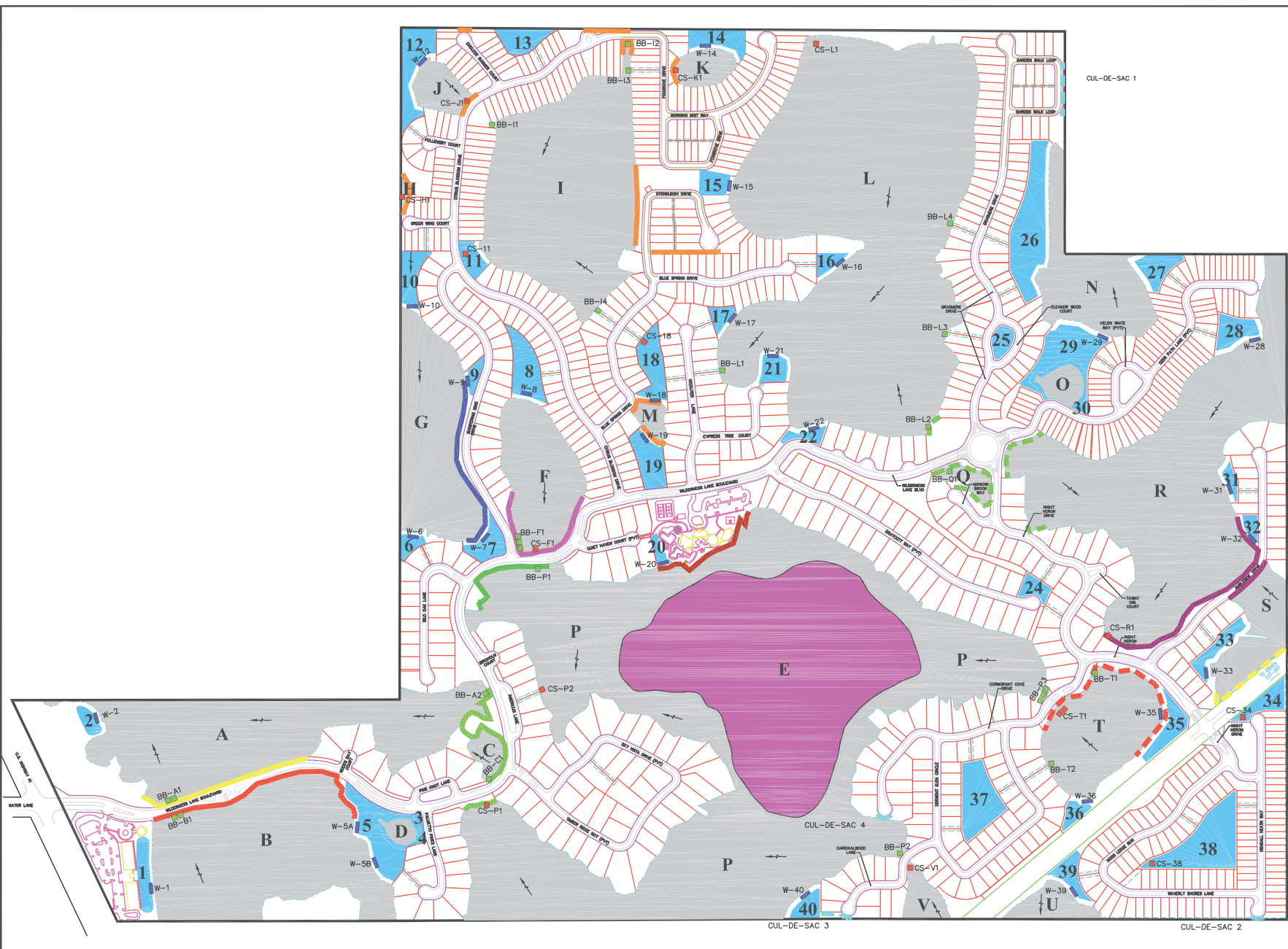

EXHIBIT 3

**Preserve at Wilderness Lake CDD
ENGINEER'S REPORT FOR July 1, 2026 BOARD MEETING**

Ongoing Projects Report and Updates:

Lodge Gutter Project

District Management has requested BDi review the ongoing project to replace/add gutters to the lodge facilities. BDi met onsite and has had correspondence with the contractor to remedy the issues with the ongoing installation on 5/26 and 5/27. Bdi will be following up as requested by the District Manager to insure the scope of the project is being followed. Further updates will be communicated/coordinated to the District Manager as received. As of 6/23, the project is still in process with anticipated completion within the next few weeks.

Shade Structure Replacement

As requested by the District Manager, BDi has reviewed the shade structure at the Oakhurst, helped solicit bids for demolition of the existing structure, and provided contact info for vendors that could provide options for replacement. BDi and the District Manager will continue to coordinate proposals for board consideration with vendors. As of this report, coordination of additional proposals and options for the board based on board feedback at the last meeting is still in process.

Parcel 35-25-18-0040-00100-000 Potential Development - (Northeast corner of US41 and Wilderness Lake Blvd)

The CDD board requested BDi to help track the permitting process of a potential development reported by the District Manager located at the entrance to the community (northeast corner of US41 and Wilderness Lake Blvd). The following is the information gathered and updates as of this report:

- SWFWMD Environmental Resource Permitting – According to the SWFWMD WMIS (Water Management Information System) which is the portal used by SWFWMD for permitting shows the most recent activity as follows:



- ERP Permit 46945.000 – Wetland Delineation Approval – This permit establishes a formal delineation of the wetland lines on the property only. It was applied for by and issued to the owner of the property, Arbor Capital Developments, LLC.
- There are records of past attempts to submit plans for various developments prior to the 2023 which show permit denials.

Update as of 6/23/26: An application to SWFWMD for an applicable ERP permit to the project was made on 6/22/26.

- Pasco County – According to the Pasco County Accela which is the portal used by the county for permitting the most recent activity is as follows:

Update as of 6/23/26: Found records of a resubmittal to Pasco County on 5/11/26. Most departments still mark the review as revisions are required. No final approval has been given yet. BDi will request/download records found.

EXHIBIT 4



Wilderness Lake Preserve Community Development District (CDD)

Wilderness Lake Preserve

21320 Wilderness Lake Blvd • Land O' Lakes, FL • 34637

Phone: 813-995-2437 • Fax: 813-995-2436

June 2026 – District/Clubhouse Operations and Maintenance Updates:

- Reported one street light outage to Duke Energy.
- Assisted with the removal of fecal contamination from the Lagoon Pool.
- Assisted with the removal of two treadmills from the Fitness Center.
- Sanitized the Men's Sauna and replaced the sauna rocks due to urine contamination.
- Deep-cleaned the Ranger Station.
- Replaced and reinforced the wooden fence at the end of Grasmere Drive.
- Installed three new poolside umbrellas.
- Removed the broken garden swing from the Stoneleigh/Foxgrove Park.
- Assisted DCSI, Inc. with configuring the new security cameras.
- Cleaned all the community benches.
- Pressure-washed the poolside pavers.
- Deep-cleaned the Fitness Center equipment.
- Tightened windscreens on the Tennis Courts.
- Installed a new water cooler in the Staff Room.
- Replaced the ADA toilet seat in the Men's Locker Room.
- Deep cleaned the Men's Locker Room.
- Replaced two tiles in the Women's Locker Room.
- Replaced two floor fans in the Fitness Center.
- Replaced three hand soap dispensers in various restrooms.
- Deep-cleaned the breezeways and patios.
- Repainted the firepit.
- Removed several wasp nests from the playgrounds.
- Rehung a mirror in the Men's Locker Room.
- Filled a hole in the embankment of the Stoneleigh pond.
- Removed an abandoned bike at the Neighborhood Park.
- Removed a dead rat from Stoneleigh Park.
- Cleaned the Nature Center carpets.
- Cleaned the maintenance shed and yard.
- Secured the camera box on the Cormorant Cove dock.
- Added a support rod to the Tennis Court observation fence.
- Repainted the Men's Locker Room ADA stall.
- Repaired several light fixtures in the Men's Locker Room.
- Removed graffiti from the Oakhurst/Woodsmere picnic table.

Prepared the facilities for scheduled events and meetings: CDD and HOA meetings, Movie Matinees, Soccer Shootout, Pool Party, Pickleball Pickups, Kid's Art Class, Bohemian Wall Art, Foot Beer Floats, Mario Kart Madness, Singles Pickleball Tournament, Water Sports, Watermelon Wednesday, Sand & Splash, Fishing Derby, Chalk Art, Kid's Class, Comedy Show, Sand Art, Pickleball Tournament, E-Sports, and numerous private events.



Wilderness Lake Preserve Community Development District (CDD)

1st, 2nd & 3rd Quarter 2025/2026 Projects:

- Repair and install additional gutters:
 - 2nd Day Custom Carpentry and General Contracting: **Repairs and installation commenced in the second week of May.**
- Reupholster the Lodge sofa and armchairs: **Fireplace and Manager's office chairs were picked up for reupholstering.**
- Reseal the parking lot.
 - Superior Sealers LLC: **Completed.**
- Create Safety Zones around all the electrical panels in the buildings: **Completed.**
- Assess the CDD-owned sidewalks: **Assessment completed. Grinding is in progress.**
- Replace the lanai lighting on the front of the Activities Center: **Completed.**
- Add additional electrical outlets in the Nature Center: **Completed.**
- Replace twelve poolside chairs: **Completed.**
- Prune the Crape Myrtle trees throughout the community: **Completed.**
- Replace poolside umbrellas: **Completed.**
- Replace Pickleball equipment: **Replaced two systems.**
- Replace windscreens on the Tennis Courts: **Replaced three panels.**
- Replace the Kubota: **Completed.**
- Replace two garden swings: **Quotes are forthcoming from Leaders Furniture and Patio Land.**
- Repair and resurface the Tennis Courts and Basketball Court.
 - **Reserves: Basketball Court: FY 2026 - \$2,801.00**
 - **Reserves: Tennis Court: FY 2029 - \$19,442.00**
 - Proposals received:
 - Florida Courts – Tennis Courts: \$46,000.00
 - Florida Courts – Basketball Court: \$9,600.00 or \$4,480.00, dependent on inclusion of Tennis Court project.
 - FDC – Tennis Court: \$22,970.00. Additional base coat: \$4,900.00
 - FDC – Basketball Court: \$5,700.00. Additional coating of fiberglass: \$1,600.00
 - FDC – Basketball Court Backboard: \$2,995.00
- Replace the Oakhurst/Woodsmere shade structure:
 - **Reserves: FY 2033 - \$10,307.00**
 - Site Masters of Florida removed the compromised structure.
 - Site Masters of Florida is submitting a proposal to remove and replace the concrete slab.
 - Proposals received:
 - Advanced Recreational Concepts: \$53,815.00 – **All inclusive.**
 - Project Innovations: \$50,500.00 – **All inclusive.**
 - Creative Shade Structures: **Forthcoming.**

Contractor & Community Updates:

2nd Day Custom Carpentry & General Contracting:

- The gutter repairs and replacements are underway.

A Total Solution:

- Requested a proposal to install an access card reader at the entrance of the Men's Sauna.



Wilderness Lake Preserve Community Development District (CDD)

Arrow Exterminators:

Treated the exterior and interior Lodge facilities with insecticide.

Cool Coast Heating and Cooling, Inc:

- Completed the quarterly maintenance on all the HVAC systems.

Cooper Pools:

- Replaced the following items:
 - Three photo sensors.
 - Replaced the grid filters on the pools.
 - Installed the electronic thermometer on the Lap Pool.

DCSI, Inc:

- Completed the installation of two security cameras and programming of the DVR.

Egis Insurance & Risk Advisors:

- Updated the District's insurance coverage to include the new Kubota.

Extreme Concrete Cleaning:

- Completed the biannual cleaning of the CDD-owned sidewalks and curbs.

Florida Coast Equipment:

- Completed the purchase of the Kubota.

Fitness Logic:

- Performed the general maintenance and cleaning of all equipment.

FitRev:

- Installed two Precor treadmills.

Leaders Furniture:

- Submitting a proposal to replace the Stoneleigh/Foxgrove park garden swing.

Oakhurst/Woodsmere Park Pavilion:

- Proposals are forthcoming to replace the pavilion.
 - Advanced Recreation Concepts – Received.
 - Florida Playstructures – Forthcoming.
 - Project Innovations, Inc. – Received.
 - Superior Sealers, LLC – Forthcoming.

Pasco County:

- Renewed the permits for the aquatics. ***Jacuzzi, Lap Pool, Lagoon Pool, and Splash Pad**

Pasco County Utilities:

- The repairs to the lift station are complete.



Wilderness Lake Preserve Community Development District (CDD)

- Replaced several ornamental grasses, shrubs, and damaged turf.
- Monitoring of the vegetation will continue.

Patio Land:

- Submitting a proposal to replace the Stoneleigh/Foxgrove garden swing.

Peloton Bikes:

- Ordered a pedal for one of the Peloton bikes.

Ready Refresh:

- Returned the water cooler after receiving a new donated cooler. **Yearly Savings: \$480.00**

RedTree:

- Weekly maintenance is in progress.
- Removal of dead vegetation and weed control is in progress.
- Requested proposals to replace the dead vegetation throughout the community.

Dead Tree Removal by Blue Line Tree Company:

- Completed the removals in the first week of June.

Romaner Graphics:

- Repaired the surface of the firepit.
- Added a lock to the Activities Center kitchen door due to missing food items from the refrigerators and cabinets.

Site Masters of Florida:

- Submitted a proposal to remove and replace the Oakhurst/Woodsmere shade structure concrete slab.

SwimKids USA:

- Commenced the summer swimming program.

Walt's Upholstery:

- Commenced the reupholstering project.

Pasco Sheriff's Special Detail Report on Citations & Warnings:

See report under separate cover.

Playground Equipment, Docks, Boats, and Sidewalk Assessments:

- Routine inspections.
- Extinguished several wasp nests throughout the community.

Scheduled Room Usage/Rentals:

In preparation for meetings or rentals, the staff on duty is responsible for preparing the room. This may include cleaning, staging tables and chairs, and providing concierge services.

*AC: Activities Center and NC: Nature Center Classroom



Wilderness Lake Preserve Community Development District (CDD)

6/1 – Storytime – Nature Center
6/1 – Resident Event – Activities Center
6/2 – Movie Matinee – Theatre
6/3 – Resident Event – Theatre
6/3 – Resident Event – Activities Center
6/3 – Resident Event – Theatre
6/5 – Private Rental – AC
6/5 – Soccer Shootout – Oakhurst/Woodsmere Park
6/6 – Private Rental – AC
6/6 – Pool Party – Poolside
6/6 – Blood Drive – Lodge Parking Lot
6/7 – Resident Event – Theatre
6/7 – Private Rental – AC
6/7 – Pickleball Pickups – Pickleball Courts
6/8 – Storytime – NC
6/8 – Kid’s Art Class – AC
6/8 – Resident Event – Lodge
6/9 – Movie Matinee – Theatre
6/9 – Deerfields’ Meeting – Theatre
6/10 – Private Rental – AC
6/10 – CDD Meeting – Theatre
6/10 – Resident Event – Theatre
6/10 – Resident Event – Nature Center
6/10 – Resident Event – AC
6/11 – Bohemian Wall Art – AC
6/12 – Root Beer Floats – AC
6/13 – Private Rental – AC
6/13 – Private Rental – NC
6/13 – Mario Kart Madness – Theatre
6/13 – Pickleball Tournament – Pickleball Tournament
6/14 – Water Sports – Lagoon Pool
6/14 – Private Rental – AC
6/15 – Storytime – NC
6/15 – Resident Event – AC
6/16 – Movie Matinee – Theatre
6/17 – Watermelon Wednesday – Poolside
6/17 – Resident Event – Theatre
6/17 – Resident Event – AC
6/17 – Resident Event – Theatre



Wilderness Lake Preserve Community Development District (CDD)

6/18 – Sand & Splash – Nature Center & Front Lawn
6/19 – Fishing Derby – AC
6/20 – Fishing Derby – AC & Lodge Dock
6/20 – Private Rental – AC
6/20 – Private Rental – NC
6/22 – Storytime – NC
6/22 – Resident Event – AC
6/22 – Chalk Art – NC Rear Patio
6/23 – HOA Meeting – AC
6/23 – Movie Matinee – Theatre
6/24 – Resident Event – Theatre
6/24 – Kid’s Cooking Class – AC
6/24 – Resident Event – AC
6/24 – Resident Event – Theatre
6/25 – Comedy Show – Theatre
6/26 – Sand Art – AC
6/27 – Private Rental – AC
6/27 – Private Rental – NC
6/27 – Pickleball Tournament – Pickle Courts
6/28 – E-Sports – Theatre
6/28 – Private Rental – AC
6/29 – Storytime – NC
6/29 – Resident Event – AC
6/30 – Movie Matinee – Theatre

Upcoming Events:

➤ **July:**

- July 4th BBQ – 7/4
- Pickleball Pickups – 7/5
- Kid’s Art Class – 7/6
- Movie Matinee – 7/7
- Popsicles by the Pool – 7/8
- Foam Art – 7/10
- Sip & Paint – 7/10
- Soap Making Class – 7/11
- Movie Night – 7/11
- E-Sports – 7/12
- Movie Matinee – 7/14
- Water Sports – 7/15



Wilderness Lake Preserve Community Development District (CDD)

- Dudes & Donuts – 7/17
- Soccer Shootout – 7/18
- Singles Pickleball Tournament – 7/19
- Movie Matinee – 7/21
- Tie Dye Day – 7/22
- Trivia Time – 7/23
- Craft Fair – 7/25
- Pickleball Tournament – 7/26
- Movie Matinee – 7/28
- Comedy Show – 7/30
- Bingo – 7/31

➤ **August:**

- S'mores Night – 8/1
- Pickleball Pickups – 8/2
- Kid's Art Class – 8/3
- Movie Matinee – 8/4
- Water Volleyball – 8/6
- Tote Bag Craft – 8/7
- Back 2 School Bash – 8/8
- Ice Cream Workshop – 8/9
- Boo Hoo Breakfast – 8/10
- Mario Kart Madness – 8/14
- Rock Painting – 8/15
- Movie Matinee – 8/16
- Friday Night Fields – 8/21
- Pasta Dinner – 8/22
- Singles Pickleball Tournament – 8/23
- Tennis Showdown – 8/28
- Pickleball Tournament – 8/29
- Water Sports – 8/30

June 28, 2026 - July 11, 2026

	Sunday June 28 E-Sports	Monday June 29 Storytime	Tuesday June 30 Movie Matinee	Wednesday July 1 CDD Mtg.	Thursday July 2	Friday July 3	Saturday July 4 BBQ & Pool Party	Total Hours
Tish	Off	Off	8:30-6:00	8:30-6:00	8:30-6:00	Off for the 4th	11:00-6:00	
Terri	Off	8:30-5:00	12:30-9:00	8:30-5:00	Off for the 4th	8:30-5:00	11:00-6:00	40.00
Steven	12:30-9:00	Off	Off	12:30-9:00	12:30-9:00	Off for the 4th	11:00-6:00	40.00
Sebastian	9:00-5:30	9:00-5:30	Off for the 4th	Off	Off	9:00-5:30	11:00-6:00	40.00
Phillip	Off for the 4th	10:00-6:30	10:00-6:30	10:00-6:30	10:00-6:30	Off	Off	40.00
Tammy	Off	5:00-9:00	9:00-1:00	Off	9:00-1:00	5:00-9:00	12:00-4:00	20.00
Erick	11:30-9:00	1:30-9:00	Off	12:30-9:00	Off	12:00-9:00	11:00-6:00	40.00
Ava	11:30-6:00	9:00-1:30	5:00-9:00	Off	5:00-9:00	9:00-1:00	Off	22.50
Pool Attendant	1:00-9:00	Off	2:00-9:00	Off	2:00-9:00	2:00-9:00	11:00-6:00	33.50
								276.00
	Sunday July 5 Pickleball Pickups	Monday July 6 Storytime & Kids Art	Tuesday July 7 Movie Matinee	Wednesday July 8, Popsicles by the Pool	Thursday July 9	Friday July 10 Foam Art & Sip & Paint	Saturday July 11 Movie Night & Soap Class	Total Hours
Tish	Off	Off	8:30-6:00	8:30-6:00	8:30-6:00	8:30-6:00	9:00-5:00	
Terri	Off	8:30-5:00	8:30-5:00	Off	8:30-5:00	12:30-9:00	9:30-6:00	40.00
Steven	12:30-9:00	Off	Off	12:30-9:00	Vac.	Vac.	Vac.	40.00
Sebastian	9:00-5:30	9:00-5:30	9:00-5:30	Off	Off	9:00-5:30	9:00-5:30	40.00
Phillip	10:00-6:30	10:00-6:30	10:00-6:30	10:00-6:30	10:00-6:30	Off	Off	40.00
Tammy	5:00-9:00	9:00-1:30	5:00-9:00	9:00-1:00	5:00-9:00	Off	Off	20.50
Erick	11:30-9:00	1:30-9:00	Off	12:30-9:00	Off	Vac.	12:30-10:00	40.00
Ava	11:30-6:00	5:00-9:00	5:00-9:00	Off	Off	5:00-9:00	5:00-10:00	23.00
Pool Attendant	1:00-9:00	Off	2:00-9:00	Off	2:00-9:00	2:00-9:00	1:00-9:00	34.50
								278.00

AM only ES - Event Setup

Can't work *30 minute lunch break required for anyone working at least 6 hours or more

PM only *1 hour lunch *30 min lunch

LR-Lodge Rep

PA - Pool Attendant

LR-Lodge Rep

July 12, 2026 - July 25, 2026

	Sunday July 12 E-Sports	Monday July 13 Storytime	Tuesday June 14 Movie Matinee	Wednesday July 15 Water Sports	Thursday July 16	Friday July 17 Dudes & Donuts	Saturday July 18 Soccer Shootout	Total Hours
Tish	Off	Off	8:30-6:00	8:30-6:00	8:30-6:00	8:30-5:00	Vac.	
Terri	Off	8:30-5:00	12:30-9:00	Off	8:30-5:00	12:30-9:00	9:00-5:30	40.00
Steven	12:30-9:00	Off	Off	12:30-9:00	12:30-9:00	8:30-5:00	1:30-10:00	40.00
Sebastian	9:00-5:30	9:00-5:30	9:00-5:30	Off	Off	9:00-5:30	9:00-5:30	40.00
Phillip	9:00-5:30	10:00-6:30	10:00-6:30	10:00-6:30	10:00-6:30	Off	Off	40.00
Tammy	Off	5:00-9:00	9:00-1:00	9:00-1:00	Off	Off	5:00-10:00	21.00
Erick	11:30-9:00	1:30-9:00	Off	12:30-9:00	Off	12:00-9:00	12:30-10:00	40.00
Ava	11:30-6:00	9:00-1:30	5:00-9:00	Off	5:00-9:00	Off	9:30-1:30	22.50
Pool Attendant	1:00-9:00	Off	2:00-9:00	Off	2:00-9:00	2:00-9:00	1:00-9:00	33.50
								277.00
	Sunday July 19 Singles PB	Monday July 20 Storytime & Kids Art	Tuesday July 21 Movie Matinee	Wednesday July 22 Tie Dye Day	Thursday July 23 Trivia Time	Friday July 24	Saturday July 25 Craft Fair	Total Hours
Tish	Off	Off	8:30-6:00	8:30-6:00	8:30-6:00	8:30-6:00	8:00-4:00	
Terri	Off	8:30-5:00	8:30-5:00	Off	8:30-5:00	8:30-5:00	9:30-6:00	40.00
Steven	8:00-4:30	Off	Off	12:30-9:00	12:30-9:00	12:30-9:00	8:00-4:00	40.00
Sebastian	9:00-5:30	9:00-5:30	9:00-5:30	Off	Off	9:00-5:30	9:00-5:30	40.00
Phillip	10:00-6:30	10:00-6:30	10:00-6:30	10:00-6:30	10:00-6:30	Off	Off	40.00
Tammy	5:00-9:00	9:00-1:30	5:00-9:00	9:00-1:00	5:00-9:00	Off	Off	20.50
Erick	11:30-9:00	1:30-9:00	Off	12:30-9:00	Off	12:00-9:00	12:30-10:00	40.00
Ava	11:30-4:30	5:00-9:00	5:00-9:00	Off	5:00-9:00	Off	5:00-10:00	22.00
Pool Attendant	1:00-9:00	Off	2:00-9:00	Off	2:00-9:00	2:00-9:00	1:00-9:00	34.50
								277.00

AM only ES - Event Setup

Can't work *30 minute lunch break required for anyone working at least 6 hours or more

PM only *1 hour lunch *30 min lunch

LR-Lodge Rep

PA - Pool Attendant

LR-Lodge Rep

Event Reconciliation October 1, 2025 - September 30, 2026

October Events	Date	# of Attendees	Budget	Revenue	Paid to Vendors	Credit Card	Total for each Month	Net
Story Time	October	10/6: 8 10/13: 6 10/20: 7 10/27: 5	\$ 50.00	\$ 0.00	\$ 0.00	(\$ 11.82)	(\$ 11.82)	(\$ 11.82)
Fishing Derby	10/3/2025	20	\$ 40.00	\$ 0.00	\$ 0.00	(\$ 33.78)	(\$ 33.78)	(\$ 33.78)
S'mores Night	10/4/2025	32	\$ 30.00	\$ 0.00	\$ 0.00	(\$ 25.16)	(\$ 25.16)	(\$ 25.16)
Pickleball Pickups	10/5/2025	5	\$ 0.00	\$ 0.00	\$ 0.00	\$ 0.00	\$ 0.00	\$ 0.00
Oktoberfest Family Festival	10/11/2024	323	\$ 3800.00	\$ 478.00	(\$ 2895.00)	(\$ 933.08)	(\$ 3828.08)	(\$3350.08)
Blood Drive	10/11/2025	6	\$ 0.00	\$ 0.00	\$ 0.00	\$ 0.00	\$ 0.00	\$ 0.00
Movie Night	10/12/2025	14	\$ 0.00	\$ 0.00	\$ 0.00	\$ 0.00	\$ 0.00	\$ 0.00
Kids Art Class	10/13/2025	14	\$ 0.00	\$ 29.00	\$ 0.00	\$ 0.00	\$ 0.00	\$ 29.00
Family Fun Day	10/14/2025	33	\$ 0.00	\$ 0.00	\$ 0.00	\$ 0.00	\$ 0.00	\$ 0.00
Dudes & Donuts	10/17/2025	9	\$ 30.00	\$ 0.00	\$ 0.00	(\$ 27.34)	(\$ 27.34)	(\$ 27.34)
Sip & Paint	10/17/2025	1	\$ 10.00	\$ 3.00	\$ 0.00	(\$ 9.69)	(\$ 9.69)	(\$ 6.69)
Comm. Garage Sale	10/18/2025	17	\$ 125.00	\$ 85.00	\$ 0.00	(\$ 122.00)	(\$ 122.00)	(\$ 37.00)
Haunted House	10/24 & 10/25	180	\$ 600.00	\$ 365.00	\$ 0.00	(\$ 638.45)	(\$ 638.45)	(\$ 273.45)
Pickleball Tournament	10/26/2025	16	\$ 20.00	\$ 0.00	\$ 0.00	(\$ 14.08)	(\$ 14.08)	(\$ 14.08)
Family History	10/27/2025	4	\$ 0.00	\$ 0.00	\$ 0.00	\$ 0.00	\$ 0.00	\$ 0.00
Spooky House Contest	10/29/2025	12	\$ 0.00	\$ 0.00	\$ 0.00	\$ 0.00	\$ 0.00	\$ 0.00
Kid's Parade	10/31/2025	160	\$ 150.00	\$ 0.00	\$ 0.00	(\$ 144.87)	(\$ 144.87)	(\$ 144.87)
Misc. Shopping for the Month	October		\$ -	\$ 0.00	\$ 0.00	(\$ 170.40)	(\$ 170.40)	(\$ 170.40)
			\$ 4,855.00	\$ 960.00	(\$ 2895.00)	(\$ 2130.67)	(\$ 5025.67)	(\$ 4065.67)
November Events	Date	# of Attendees	Budget	Revenue	Paid to Vendors	Credit Card	Total for each Month	Net
Story Time	November	11/3: 6 11/10: 8 11/17: 6 11/24: 5	\$ 50.00	\$ 0.00	\$ 0.00	(\$ 11.82)	(\$ 11.82)	(\$ 11.82)
Art Class - Canceled	11/1/2025	0	\$ 10.00	\$ 0.00	\$ 0.00	\$ 0.00	\$ 0.00	\$ 0.00
Pickleball Pickups	11/2/2025	12	\$ 10.00	\$ 0.00	\$ 0.00	\$ 0.00	\$ 0.00	\$ 0.00
Art & Craft Fair	11/8/2025	30 booths & 175 guests	\$ 250.00	\$ 300.00	\$ 0.00	(\$ 177.30)	(\$ 177.30)	\$ 122.70

Event Reconciliation October 1, 2025 - September 30, 2026

Music Bingo	11/9/2025	7	\$ 10.00	\$ 0.00	\$ 0.00	(\$ 6.95)	(\$ 6.95)	(\$ 6.95)
Veteran's Day Celebration	11/11/2025	10	\$ 40.00	\$ 0.00	\$ 0.00	(\$ 38.84)	(\$ 38.84)	(\$ 38.84)
Friday Night Fields	11/14/2025	22	\$ 15.00	\$ 0.00	\$ 0.00	\$ 0.00	\$ 0.00	\$ 0.00
Soap Making Class	11/15/2025	15	\$ 0.00	\$ 0.00	\$ 0.00	\$ 0.00	\$ 0.00	\$ 0.00
Caring & Sharing Feast	11/16/2025	43	\$ 30.00	\$ 0.00	\$ 0.00	(\$ 29.88)	(\$ 29.88)	(\$ 29.88)
Genealogy Class	11/17/2025	3	\$ 0.00	\$ 0.00	\$ 0.00	\$ 0.00	\$ 0.00	\$ 0.00
Sip & Paint - Canceled	11/21/2025	0	\$ 0.00	\$ 0.00	\$ 0.00	\$ 0.00	\$ 0.00	\$ 0.00
Scavenger Hunt	11/22/2025	7	\$ 10.00	\$ 0.00	\$ 0.00	(\$ 5.99)	(\$ 5.99)	(\$ 5.99)
Trivia Time	11/23/2025	7	\$ 10.00	\$ 0.00	\$ 0.00	(\$ 5.99)	(\$ 5.99)	(\$ 5.99)
Kids Art Class	11/24/2025	16	\$ 0.00	\$ 32.00	\$ 0.00	\$ 0.00	\$ 0.00	\$ 32.00
E-Sports	11/25/2025	4	\$ 0.00	\$ 0.00	\$ 0.00	\$ 0.00	\$ 0.00	\$ 0.00
Turkey Trot	11/27/2025	76	\$ 250.00	\$ 0.00	\$ 0.00	(\$ 208.94)	(\$ 208.94)	(\$ 208.94)
Tie Dye Day	11/28/2025	22	\$ 35.00	\$ 0.00	\$ 0.00	(\$ 31.78)	(\$ 31.78)	(\$ 31.78)
S'mores Night	11/29/2025	54	\$ 50.00	\$ 0.00	\$ 0.00	(\$ 60.70)	(\$ 60.70)	(\$ 60.70)
Pickleball Tournament	11/30/2025	16	\$ 10.00	\$ 0.00	\$ 0.00	(\$ 2.24)	(\$ 2.24)	(\$ 2.24)
Misc. Shopping for the Month	November		\$ -	\$ 0.00	\$ 0.00	(\$ 186.55)	(\$ 186.55)	(\$ 186.55)
			\$ 780.00	\$ 332.00	\$ 0.00	(\$ 766.98)	(\$ 766.98)	(\$ 434.98)
December Events	Date	# of Attendees	Budget	Revenue	Paid to Vendors	Credit Card	Total for each Month	Net
Story Time	December	12/1: 5 12/8: 7 12/15: 5 12/22: 7 12/29: 8	\$ 50.00	\$ 0.00	\$ 0.00	(\$ 9.38)	(\$ 9.38)	(\$ 9.38)
Santa Arrival & Tree Lighting	12/6/2025	325+/-	\$ 2,600.00	\$ 0.00	(\$ 1710.00)	(\$ 710.88)	(\$ 2420.88)	(\$ 2420.88)
Blood Drive	12/6/2025	10	\$ 0.00	\$ 0.00	\$ 0.00	\$ 0.00	\$ 0.00	\$ 0.00
Pickleball Pickups	12/7/2025	2	\$ 0.00	\$ 0.00	\$ 0.00	\$ 0.00	\$ 0.00	\$ 0.00
Movie on the Lawn	12/12/2025	20	\$ 15.00	\$ 0.00	\$ 0.00	(\$ 10.38)	(\$ 10.38)	(\$ 10.38)
Gingerbread Workshop	12/13/2025	21	\$ 150.00	\$ 100.00	\$ 0.00	(\$ 250.23)	(\$ 250.23)	(\$ 150.23)
Lighting of the Menorah	12/14/2025	12	\$ 75.00	\$ 0.00	\$ 0.00	(\$ 76.69)	(\$ 76.69)	(\$ 76.69)
Breakfast with Santa	12/20/2025	230	\$ 2000.00	\$ 813.00	(\$ 1260.00)	(\$ 601.75)	(\$ 1861.75)	(\$ 1048.75)
Movie Night	12/21/2025	10	\$ 5.00	\$ 0.00	\$ 0.00	(\$ 5.19)	(\$ 5.19)	(\$ 5.19)
Best Decorated House	12/21/2025	6	\$ 50.00	\$ 0.00	\$ 0.00	(\$ 52.43)	(\$ 52.43)	(\$ 52.43)
Sand Art	12/22/2025	21	\$ 50.00	\$ 0.00	\$ 0.00	(\$ 54.18)	(\$ 54.18)	(\$ 54.18)

Event Reconciliation October 1, 2025 - September 30, 2026

Video Game Mania	12/23/2025	16	\$ 10.00	\$ 0.00	\$ 0.00	(\$ 5.19)	(\$ 5.19)	(\$ 5.19)
Soccer Shootout	12/26/2025	22	\$ 0.00	\$ 0.00	\$ 0.00	\$ 0.00	\$ 0.00	\$ 0.00
Bounce in the New Year	12/27/2025	66	\$ 700.00	\$ 114.00	(\$ 516.90)	(\$ 114.34)	(\$ 631.24)	(\$ 517.24)
Pickleball Tournament	12/28/2025	16	\$ 0.00	\$ 0.00	\$ 0.00	\$ 0.00	\$ 0.00	\$ 0.00
Kid's Art	12/29/2025	11	\$ 0.00	\$ 22.00	\$ 0.00	(\$ 5.19)	(\$ 5.19)	\$ 16.81
Movie Matinee	12/30/2025	7	\$ 10.00	\$ 0.00	\$ 0.00	(\$ 5.19)	(\$ 5.19)	(\$ 5.19)
Misc. Shopping for the Month	December		\$ -	\$ 0.00	\$ 0.00	(\$ 429.01)	(\$ 429.01)	(\$ 429.01)
			\$ 5,715.00	\$ 1049.00	(\$ 3486.90)	(\$ 2330.03)	(\$ 5816.93)	(\$ 4767.93)
January Events	Date	# of Attendees	Budget	Revenue	Paid to Vendors	Credit Card	Total for each Month	Net
Story Time (4 Wk.)	January	1/5: 8 1/12: 6 1/19: 15 1/26: 5	\$ 50.00	\$ 0.00	\$ 0.00	\$ 0.00	\$ 0.00	\$ 0.00
Pickleball Pickups	1/2/2026	11	\$ 0.00	\$ 0.00	\$ 0.00	\$ 0.00	\$ 0.00	\$ 0.00
Bohemian Wall Art	1/3/2026	8	\$ 0.00	\$ 0.00	\$ 0.00	\$ 0.00	\$ 0.00	\$ 0.00
Worm Farms	1/4/2026	8	\$ 50.00	\$ 0.00	\$ 0.00	(\$ 63.76)	(\$ 63.76)	(\$ 63.76)
Chalk Art	1/5/2026	12	\$ 0.00	\$ 0.00	\$ 0.00	\$ 0.00	\$ 0.00	\$ 0.00
Volunteer Appreciation Dinner	1/9/2026	27	\$ 150.00	\$ 0.00	\$ 0.00	(\$ 116.00)	(\$ 116.00)	(\$ 116.00)
Birdhouse Workshop	1/10/2026	23	\$ 40.00	\$ 0.00	\$ 0.00	(\$ 23.99)	(\$ 23.99)	(\$ 23.99)
Game Day- (Inside)	1/11/2026	17	\$ 0.00	\$ 0.00	\$ 0.00	\$ 0.00	\$ 0.00	\$ 0.00
Game Night	1/16/2026	5	\$ 0.00	\$ 0.00	\$ 0.00	\$ 0.00	\$ 0.00	\$ 0.00
Wine Tasting	1/17/2026	29	\$ 800.00	\$ 120.00	(\$ 640.95)	(\$ 151.41)	(\$ 792.36)	(\$672.36)
Dino Dig	1/18/2026	31	\$ 50.00	\$ 0.00	\$ 0.00	(\$ 60.49)	(\$ 60.49)	(\$ 60.49)
Kids Art Class - Canceled	1/19/2026	0	\$ 0.00	\$ 0.00	\$ 0.00	\$ 0.00	\$ 0.00	\$ 0.00
Movie Matinee	1/19/2026	5	\$ 0.00	\$ 0.00	\$ 0.00	\$ 0.00	\$ 0.00	\$ 0.00
Movie Night	1/23/2026	8	\$ 10.00	\$ 0.00	\$ 0.00	(\$ 12.89)	(\$ 12.89)	(\$12.89)
Sip & Paint	1/23/2026	4	\$ 0.00	\$ 12.00	\$ 0.00	\$ 0.00	\$ 0.00	\$ 12.00
Hot Cocoa Bar	1/24/2026	34	\$ 25.00	\$ 0.00	\$ 0.00	(\$ 16.06)	(\$ 16.06)	(\$ 16.06)
Pickleball Tournament	1/25/2026	16	\$ 15.00	\$ 0.00	\$ 0.00	(\$ 12.18)	(\$ 12.18)	(\$ 12.18)
Mario Kart Madness	1/30/2026	6	\$ 0.00	\$ 0.00	\$ 0.00	\$ 0.00	\$ 0.00	\$ 0.00
Kids Art Workshop - Canceled	1/31/2026	0	\$ 0.00	\$ 0.00	\$ 0.00	\$ 0.00	\$ 0.00	\$ 0.00
Misc. Shopping for the Month	January		\$ -	\$ 0.00	\$ 0.00	(\$ 28.47)	(\$ 28.47)	(\$ 28.47)
			\$ 1,190.00	\$ 132.00	(\$ 640.95)	(\$ 485.25)	(\$ 1126.20)	(\$ 994.20)

Event Reconciliation October 1, 2025 - September 30, 2026

February Events	Date	# of Attendees	Budget	Revenue	Paid to Vendors	Credit Card	Total for each Month	Net
Story Time (4 Wk.)	February	2/2: 6 2/9: 4 2/16: 4 2/23: 7	\$ 50.00	\$ 0.00	\$ 0.00	(\$ 7.98)	(\$ 7.98)	(\$ 7.98)
King of the Court (Basketball) -	2/1/2026	3	\$ 0.00	\$ 0.00	\$ 0.00	\$ 0.00	\$ 0.00	\$ 0.00
Dudes & Donuts	2/6/2026	12	\$ 40.00	\$ 0.00	\$ 0.00	(\$ 33.34)	(\$ 33.34)	(\$ 33.34)
Sip & Paint - Canceled	2/6/2026	0	\$ 0.00	\$ 0.00	\$ 0.00	\$ 0.00	\$ 0.00	\$ 0.00
Pickleball Pickups	2/7/2026	11	\$ 10.00	\$ 0.00	\$ 0.00	(\$ 4.99)	(\$ 4.99)	(\$ 4.99)
Crafternoon	2/8/2026	23	\$ 15.00	\$ 0.00	\$ 0.00	(\$ 11.98)	(\$ 11.98)	(\$ 11.98)
Movie Night	2/13/2026	18	\$ 0.00	\$ 0.00	\$ 0.00	\$ 0.00	\$ 0.00	\$ 0.00
Valentine's Day Dinner	2/14/2026	31	\$ 300.00	\$ 218.00	\$ 0.00	(\$ 293.84)	(\$ 293.84)	(\$ 75.84)
E-Sports	2/15/2026	3	\$ 0.00	\$ 0.00	\$ 0.00	\$ 0.00	\$ 0.00	\$ 0.00
Kids Art Class	2/16/2026	12	\$ 0.00	\$ 24.00	\$ 0.00	\$ 0.00	\$ 0.00	\$ 24.00
Soccer Shootout	2/20/2026	11	\$ 0.00	\$ 0.00	\$ 0.00	\$ 0.00	\$ 0.00	\$ 0.00
Rock Painting	2/21/2026	17	\$ 25.00	\$ 0.00	\$ 0.00	(\$ 23.74)	(\$ 23.74)	(\$ 23.74)
Sunday Sundaes	2/22/2026	49	\$ 50.00	\$ 0.00	\$ 0.00	(\$ 44.02)	(\$ 44.02)	(\$ 44.02)
Pickleball Tournament	2/28/2026	16	\$ 10.00	\$ 0.00	\$ 0.00	(\$ 8.25)	(\$ 8.25)	(\$ 8.25)
Kid's Art Workshop	2/28/2026	4	\$ 0.00	\$ 5.00	\$ 0.00	\$ 0.00	\$ 0.00	\$ 5.00
Misc. Shopping for the Month	February		\$ -	\$ 0.00	\$ 0.00	(\$ 59.92)	(\$ 59.92)	(\$ 59.92)
			\$ 500.00	\$ 247.00	\$ 0.00	(\$ 488.06)	(\$ 488.06)	(\$ 241.06)
March Events	Date	# of Attendees	Budget	Revenue	Paid to Vendors	Credit Card	Total for each Month	Net
Story Time (4 Wk.)	March	3/2: 6 3/9: 8 3/16: 6 3/23: 9 3/30: 7	\$ 50.00	\$ 0.00	\$ 0.00	(\$ 11.82)	(\$ 11.82)	(\$ 11.82)
Super Smash Bros.	3/1/2026	9	\$ 0.00	\$ 0.00	\$ 0.00	\$ 0.00	\$ 0.00	\$ 0.00
Sip & Paint	3/6/2026	3	\$ 0.00	\$ 9.00	\$ 0.00	\$ 0.00	\$ 0.00	\$ 0.00
Cereal Social	3/7/2026	10	\$ 30.00	\$ 8.00	\$ 0.00	(\$ 29.48)	(\$ 29.48)	(\$ 29.48)
Pickleball Pickups	3/8/2026	15	\$ 5.00	\$ 0.00	\$ 0.00	(\$ 2.31)	(\$ 2.31)	(\$ 2.31)
Movie Night	3/13/2026	3	\$ 0.00	\$ 0.00	\$ 0.00	\$ 0.00	\$ 0.00	\$ 0.00

Event Reconciliation October 1, 2025 - September 30, 2026

St. Patrick's Day Fest	3/14/2026	46	\$ 500.00	\$ 230.00	(\$ 295.00)	(\$ 216.22)	(\$ 511.22)	(\$ 281.22)
Pickleball Tournament	3/15/2026	16	\$ 0.00	\$ 0.00	\$ 0.00	\$ 0.00	\$ 0.00	\$ 0.00
Grill & Chill	3/20/2026	15	\$ 0.00	\$ 0.00	\$ 0.00	\$ 0.00	\$ 0.00	\$ 0.00
Community Garage Sale	3/21/2026	15	\$ 100.00	\$ 75.00	\$ 0.00	(\$ 70.00)	(\$ 70.00)	\$ 5.00
Trivia Time	3/21/2026	1	\$ 0.00	\$ 0.00	\$ 0.00	\$ 0.00	\$ 0.00	\$ 0.00
Game Night	3/27/2026	11	\$ 0.00	\$ 0.00	\$ 0.00	\$ 0.00	\$ 0.00	\$ 0.00
Pickleball Tournament	3/28/2026	16	\$ 5.00	\$ 0.00	\$ 0.00	(\$ 2.33)	(\$ 2.33)	(\$ 2.33)
Water Sports	3/29/2026	8	\$ 0.00	\$ 0.00	\$ 0.00	\$ 0.00	\$ 0.00	\$ 0.00
Kid's Art Class	3/30/2026	8	\$ 0.00	\$ 16.00	\$ 0.00	\$ 0.00	\$ 0.00	\$ 16.00
Tie Dye Day	3/31/2026	12	\$ 30.00	\$ 0.00	\$ 0.00	(\$ 30.54)	(\$ 30.54)	(\$ 30.54)
Misc. Shopping for the Month	March		\$ -	\$ 0.00	\$ 0.00	(\$ 46.45)	(\$ 46.45)	(\$ 46.45)
			\$ 720.00	\$ 338.00	(\$ 295.00)	(\$ 409.15)	(\$ 704.15)	(\$ 383.15)
April Events	Date	# of Attendees	Budget	Revenue	Paid to Vendors	Credit Card	Total for each Month	Net
Story Time (5 Wk.)	April	4/6: 8 4/13: 5 4/20: 7 4/27: 11	\$ 50.00	\$ 0.00	\$ 0.00	\$ 0.00	\$ 0.00	\$ 0.00
Snow Cone Social	4/1/2026	31	\$ 30.00	\$ 0.00	\$ 0.00	(\$ 30.54)	(\$ 30.54)	(\$ 30.54)
Pickleball Pickups	4/1/2026	33	\$ 70.00	\$ 0.00	\$ 0.00	(\$ 65.46)	(\$ 65.46)	(\$ 65.46)
Movie Night	4/2/2026	17	\$ 0.00	\$ 0.00	\$ 0.00	\$ 0.00	\$ 0.00	\$ 0.00
Kid's Soap Making Workshop - Canceled	4/2/2026	0	\$ 0.00	\$ 0.00	\$ 0.00	\$ 0.00	\$ 0.00	\$ 0.00
Game Day - (Inside) & Water Sports	4/2/2025	15	\$ 0.00	\$ 0.00	\$ 0.00	\$ 0.00	\$ 0.00	\$ 0.00
Field Night	4/3/2026	18	\$ 0.00	\$ 0.00	\$ 0.00	\$ 0.00	\$ 0.00	\$ 0.00
Easter Celebration	4/4/2026	250	\$ 3800.00	\$ 555.00	(\$ 2295.00)	(\$ 1809.90)	(\$ 4104.90)	(\$ 3549.90)
Ladies Night	4/10/2026	3	\$ 15.00	\$ 9.00	\$ 0.00	(\$ 13.98)	(\$ 13.98)	(\$ 4.98)
Lightning Watch Party	4/11/2026	14	\$ 130.00	\$ 0.00	\$ 0.00	(\$ 120.23)	(\$ 120.23)	(\$ 120.23)
Snow Cone Social	4/12/2026	85	\$ 0.00	\$ 0.00	\$ 0.00	\$ 0.00	\$ 0.00	\$ 0.00
Mario Kart Madness	4/17/2026	17	\$ 0.00	\$ 0.00	\$ 0.00	\$ 0.00	\$ 0.00	\$ 0.00
Business Expo	4/18/2026	19 Booths	\$ 200.00	\$ 220.00	\$ 0.00	(\$ 179.84)	(\$ 179.84)	\$ 40.16
Pickleball Tournament (Singles)	4/19/2026	16	\$ 5.00	\$ 0.00	\$ 0.00	(\$ 1.46)	(\$ 1.46)	(\$ 1.46)
Family Bingo	4/25/2026	19	\$ 10.00	\$ 0.00	\$ 0.00	(\$ 81.55)	(\$ 81.55)	(\$ 81.55)

Event Reconciliation October 1, 2025 - September 30, 2026

Pickleball Tournament	4/26/2026	16	\$ 5.00	\$ 0.00	\$ 0.00	(\$ 5.99)	(\$ 5.99)	(\$ 5.99)
Misc. Shopping for the Month	April		\$ -	\$ 0.00	\$ 0.00	(\$ 48.95)	(\$ 48.95)	(\$ 48.95)
			\$ 4315.00	\$ 784.00	(\$ 2295.00)	(\$ 2357.90)	(\$ 4652.90)	(\$ 3868.90)
May Events	Date	# of Attendees	Budget	Revenue	Paid to Vendors	Credit Card	Total for each Month	Net
Story Time (5 Wk.)	May	5/4: 8 5/11: 6 5/18: 10	\$ 50.00	\$ 0.00	\$ 0.00	\$ 0.00	\$ 0.00	\$ 0.00
Friday Night Fields	5/1/2026	22	\$ 0.00	\$ 0.00	\$ 0.00	\$ 0.00	\$ 0.00	\$ 0.00
Cinco de Mayo Happy Hour	5/2/2026	25	\$ 200.00	\$ 96.00	\$ 0.00	(\$ 189.46)	(\$ 189.46)	(\$ 93.46)
Pickleball Pickups	5/3/2026	17	\$ 5.00	\$ 0.00	\$ 0.00	(\$ 1.94)	(\$ 1.94)	(\$ 1.94)
Comedy Show	5/7/2026	26	\$ 30.00	\$ 25.00	\$ 0.00	(\$ 31.85)	(\$ 31.85)	(\$ 6.85)
Movie Night	5/8/2026	2	\$ 0.00	\$ 0.00	\$ 0.00	\$ 0.00	\$ 0.00	\$ 0.00
Ladies Wine Glass Painting	5/8/2026	2	\$ 0.00	\$ 6.00	\$ 0.00	\$ 0.00	\$ 0.00	\$ 6.00
Mother's Day Tea	5/9/2026	27	\$ 200.00	\$ 54.00	\$ 0.00	(\$ 136.28)	(\$ 136.28)	(\$ 82.28)
Urban Recycling Day	5/14 & 5/15/2026	21	\$ 50.00	\$ 0.00	\$ 0.00	(\$ 52.33)	(\$ 52.33)	(\$ 52.33)
Kid's Art Class - Canceled	5/16/2026	0	\$ 0.00	\$ 0.00	\$ 0.00	\$ 0.00	\$ 0.00	\$ 0.00
Water Sports - Inclement Weather	5/17/2026	0	\$ 0.00	\$ 0.00	\$ 0.00	\$ 0.00	\$ 0.00	\$ 0.00
Singles Pickleball Tournament - Inclement Weather	5/17/2026	0	\$ 5.00	\$ 0.00	\$ 0.00	(\$ 1.94)	(\$ 1.94)	(\$ 1.94)
Flower Pot Painting	5/22/2026	11	\$ 50.00	\$ 0.00	\$ 0.00	(\$ 71.50)	(\$ 71.50)	(\$ 71.50)
Memorial Day BBQ	5/23/2026	155	\$ 1100.00	\$ 453.00	(\$ 509.59)	(\$ 361.88)	(\$ 871.47)	(\$ 418.47)
Super Smash Bros. Tournament	5/24/2026	10	\$ 0.00	\$ 0.00	\$ 0.00	\$ 0.00	\$ 0.00	\$ 0.00
Wooden Airplane Craft	5/29/2026	18	\$ 30.00	\$ 0.00	\$ 0.00	(\$ 27.98)	(\$ 27.98)	(\$ 27.98)
Pickleball Tournament	5/30/2026	16	\$ 5.00	\$ 0.00	\$ 0.00	(\$ 2.00)	(\$ 2.00)	(\$ 2.00)
Water Basketball	5/31/2026	16	\$ 0.00	\$ 0.00	\$ 0.00	\$ 0.00	\$ 0.00	\$ 0.00
Misc. Shopping for the Month	May		\$ -	\$ 0.00	\$ 0.00	(\$ 100.70)	(\$ 100.70)	(\$ 100.70)
			\$ 1725.00	\$ 634.00	(\$ 509.59)	(\$ 977.86)	(\$ 1487.45)	(\$ 823.47)
June Events	Date	# of Attendees	Budget	Revenue	Paid to Vendors	Credit Card	Total for each Month	Net

Event Reconciliation October 1, 2025 - September 30, 2026

Story Time (4 Wk.)	June	6/1 6/8 6/15 6/22	\$ 50.00	\$ 0.00	\$ 0.00	\$ 0.00	\$ 0.00	\$ 0.00
Movie Matinee	6/3/2026	5	\$ 0.00	\$ 0.00	\$ 0.00	\$ 0.00	\$ 0.00	\$ 0.00
Soccer Shootout	6/5/2026	5	\$ 0.00	\$ 0.00	\$ 0.00	\$ 0.00	\$ 0.00	\$ 0.00
Pool Party	6/6/2026	75	\$ 600.00	\$ 0.00	(\$ 595.00)	(\$ 6.00)	(\$ 601.00)	(\$ 601.00)
Blood Drive	6/6/2026	10	\$ 0.00	\$ 0.00	\$ 0.00	\$ 0.00	\$ 0.00	\$ 0.00
Pickleball Pickups	6/7/2026	13	\$ 0.00	\$ 0.00	\$ 0.00	(\$ 1.42)	(\$ 1.42)	(\$ 1.42)
Kid's Art Class	6/8/2026	17	\$ 0.00	\$ 38.00	\$ 0.00	\$ 0.00	\$ 0.00	\$ 38.00
Movie Matinee	6/9/2026	12	\$ 0.00	\$ 0.00	\$ 0.00	\$ 0.00	\$ 0.00	\$ 0.00
Bohemian Wall Art	6/11/2026	6	\$ 0.00	\$ 0.00	\$ 0.00	\$ 0.00	\$ 0.00	\$ 0.00
Root Beer Floats	6/12/2026	34	\$ 36.00	\$ 39.00	\$ 0.00	(\$ 35.47)	(\$ 35.47)	\$ 3.53
Mario Kart Madness	6/13/2026	7	\$ 0.00	\$ 0.00	\$ 0.00	\$ 0.00	\$ 0.00	\$ 0.00
Water Sports	6/14/2026	17	\$ 0.00	\$ 0.00	\$ 0.00	\$ 0.00	\$ 0.00	\$ 0.00
Movie Matinee	6/15/2026	15	\$ 0.00	\$ 0.00	\$ 0.00	\$ 0.00	\$ 0.00	\$ 0.00
Watermelon Wednesday	6/17/2026	19	\$ 0.00	\$ 0.00	\$ 0.00	\$ 0.00	\$ 0.00	\$ 0.00
Sand & Splash	6/18/2026	21	\$ 50.00	\$ 0.00	\$ 0.00	(\$ 46.24)	(\$ 46.24)	(\$ 46.24)
Fishing Derby	6/19 & 6/20/2026	18	\$ 125.00	\$ 70.00	\$ 0.00	(\$ 116.70)	(\$ 116.70)	\$ 46.70
Chalk Art	6/22/2026		\$ 0.00	\$ 0.00	\$ 0.00	\$ 0.00	\$ 0.00	\$ 0.00
Movie Matinee	6/23/2026		\$ 0.00	\$ 0.00	\$ 0.00	\$ 0.00	\$ 0.00	\$ 0.00
Kid's Cooking Class	6/24/2026		\$ 100.00	\$ 0.00	\$ 0.00	\$ 0.00	\$ 0.00	\$ 0.00
Comedy Show	6/25/2026		\$ 25.00	\$ 0.00	\$ 0.00	\$ 0.00	\$ 0.00	\$ 0.00
Sand Art	6/26/2026		\$ 20.00	\$ 0.00	\$ 0.00	\$ 0.00	\$ 0.00	\$ 0.00
Pickleball Tournament	6/27/2026		\$ 5.00	\$ 0.00	\$ 0.00	\$ 0.00	\$ 0.00	\$ 0.00
E-Sports	6/28/2026		\$ 0.00	\$ 0.00	\$ 0.00	\$ 0.00	\$ 0.00	\$ 0.00
Movie Matinee	6/30/2026		\$ 0.00	\$ 0.00	\$ 0.00	\$ 0.00	\$ 0.00	\$ 0.00
Misc. Shopping for the Month	June		\$ -	\$ 0.00	\$ 0.00	(\$ 88.70)	(\$ 88.70)	(\$ 88.70)
			\$ 1011.00	\$ 147.00	(\$ 595.00)	(\$ 294.53)	(\$ 889.53)	(\$ 649.13)
July Events	Date	# of Attendees	Budget	Revenue	Paid to Vendors	Credit Card	Total for each Month	Net

Event Reconciliation October 1, 2025 - September 30, 2026

Story Time (5 Wk.)	July		\$ 50.00	\$ 0.00	\$ 0.00	\$ 0.00	\$ 0.00	
Movie Matinee	7/1/2026		\$ 0.00	\$ 0.00	\$ 0.00	\$ 0.00	\$ 0.00	
July 4th BBQ	7/4/2026		\$1,200.00	\$ 0.00	(\$ 495.00)	(\$ 495.00)	(\$ 495.00)	(\$ 495.00)
Pickleball Pickups	7/5/2026		\$ 0.00	\$ 0.00	\$ 0.00	\$ 0.00	\$ 0.00	
Kid's Art Class	7/6/2026		\$ 0.00	\$ 0.00	\$ 0.00	\$ 0.00	\$ 0.00	
Movie Matinee	7/8/2026		\$ 0.00	\$ 0.00	\$ 0.00	\$ 0.00	\$ 0.00	
Foam Art	7/10/2026		\$ 15.00	\$ 0.00	\$ 0.00	\$ 0.00	\$ 0.00	
Movie Night	7/11/2026		\$ 0.00	\$ 0.00	\$ 0.00	\$ 0.00	\$ 0.00	
E-Sports	7/12/2026		\$ 0.00	\$ 0.00	\$ 0.00	\$ 0.00	\$ 0.00	
Water Sports	7/14/2026		\$ 0.00	\$ 0.00	\$ 0.00	\$ 0.00	\$ 0.00	
Movie Matinee	7/15/2026		\$ 0.00	\$ 0.00	\$ 0.00	\$ 0.00	\$ 0.00	
Soccer Shootout	7/17/2026		\$ 10.00	\$ 0.00	\$ 0.00	\$ 0.00	\$ 0.00	
Dudes & Donuts	7/18/2026		\$ 30.00	\$ 0.00	\$ 0.00	\$ 0.00	\$ 0.00	
Water Basketball	7/19/2026		\$ 0.00	\$ 0.00	\$ 0.00	\$ 0.00	\$ 0.00	
Sand & Splash	7/21/2026		\$ 15.00	\$ 0.00	\$ 0.00	\$ 0.00	\$ 0.00	
Movie Matinee	7/22/2026		\$ 0.00	\$ 0.00	\$ 0.00	\$ 0.00	\$ 0.00	
Craft Fair	7/25/2026		\$ 300.00	\$ 0.00	\$ 0.00	\$ 0.00	\$ 0.00	
Pickleball Tournament	7/26/2026		\$ 0.00	\$ 0.00	\$ 0.00	\$ 0.00	\$ 0.00	
Movie Matinee	7/29/2026		\$ 0.00	\$ 0.00	\$ 0.00	\$ 0.00	\$ 0.00	
Tie Dye Day	7/30/2026		\$10.00	\$ 0.00	\$ 0.00	\$ 0.00	\$ 0.00	
Popsicles by the Pool	7/31/2026		\$10.00	\$ 0.00	\$ 0.00	\$ 0.00	\$ 0.00	
Misc. Shopping for the Month	July		\$ -	\$ 0.00	\$ 0.00	\$ 0.00	\$ 0.00	
			\$ 1640.00	\$ 0.00	(\$ 495.00)	(\$ 495.00)	(\$ 495.00)	(\$ 495.00)
August Events	Date	# of Attendees	Budget	Revenue	Paid to Vendors	Credit Card	Total for each Month	Net
Story Time (4 Wk.)	August		\$ 50.00	\$ 0.00	\$ 0.00	\$ 0.00	\$ 0.00	
S'mores Night	8/1/2026		\$ 25.00	\$ 0.00	\$ 0.00	\$ 0.00	\$ 0.00	
Pickleball Pickups	8/2/2026		\$ 0.00	\$ 0.00	\$ 0.00	\$ 0.00	\$ 0.00	
Kid's Art Class	8/3/2026		\$ 0.00	\$ 0.00	\$ 0.00	\$ 0.00	\$ 0.00	
Movie Matinee	8/5/2026		\$ 0.00	\$ 0.00	\$ 0.00	\$ 0.00	\$ 0.00	
Water Volleyball	8/6/2026		\$ 0.00	\$ 0.00	\$ 0.00	\$ 0.00	\$ 0.00	
Tote Bag Craft	8/7/2026		\$ 25.00	\$ 0.00	\$ 0.00	\$ 0.00	\$ 0.00	
Back to School Bash	8/8/2026		\$ 500.00	\$ 0.00	\$ 0.00	\$ 0.00	\$ 0.00	

Event Reconciliation October 1, 2025 - September 30, 2026

Movie Matinee	8/9/2026		\$ 0.00	\$ 0.00	\$ 0.00	\$ 0.00	\$ 0.00	
Boo Hoo Breakfast	8/11/2026		\$ 50.00	\$ 0.00	\$ 0.00	\$ 0.00	\$ 0.00	
Friday Night Fields	8/14/2026		\$ 0.00	\$ 0.00	\$ 0.00	\$ 0.00	\$ 0.00	
Pasta Dinner	8/15/2026		\$ 150.00	\$ 0.00	\$ 0.00	\$ 0.00	\$ 0.00	
Music Bingo	8/16/2026		\$ 20.00	\$ 0.00	\$ 0.00	\$ 0.00	\$ 0.00	
Rock Painting	8/21/2026		\$ 20.00	\$ 0.00	\$ 0.00	\$ 0.00	\$ 0.00	
Tennis Showdown	8/22/2026		\$ 0.00	\$ 0.00	\$ 0.00	\$ 0.00	\$ 0.00	
Trivia Time	8/23/2026		\$ 0.00	\$ 0.00	\$ 0.00	\$ 0.00	\$ 0.00	
Pickleball Tournament	8/29/2026		\$ 0.00	\$ 0.00	\$ 0.00	\$ 0.00	\$ 0.00	
Mario Kart Madness	8/30/2026		\$ 0.00	\$ 0.00	\$ 0.00	\$ 0.00	\$ 0.00	
Misc. Shopping for the Month	August		\$ -	\$ 0.00	\$ 0.00	\$ 0.00	\$ 0.00	
			\$ 840.00	\$ 0.00	\$ 0.00	\$ 0.00	\$ 0.00	
September Events	Date	# of Attendees	Budget	Revenue	Paid to Vendors	Credit Card	Total for each Month	Net
Story Time (5 Wk.)	September		\$ 50.00	\$ 0.00	\$ 0.00	\$ 0.00	\$ 0.00	
Pickleball Pickups	9/3/2026		\$ 0.00	\$ 0.00	\$ 0.00	\$ 0.00	\$ 0.00	
Movie Night	9/4/2026		\$ 0.00	\$ 0.00	\$ 0.00	\$ 0.00	\$ 0.00	
Labor Day BBQ	9/5/2026		\$ 1500.00	\$ 0.00	\$ 0.00	\$ 0.00	\$ 0.00	
E-Sports	9/6/2026		\$ 0.00	\$ 0.00	\$ 0.00	\$ 0.00	\$ 0.00	
Kid's Art Class	9/7/2026		\$ 0.00	\$ 0.00	\$ 0.00	\$ 0.00	\$ 0.00	
Soccer Shootout	9/11/2026		\$ 0.00	\$ 0.00	\$ 0.00	\$ 0.00	\$ 0.00	
Singles Pickleball Tournament	9/12/2026		\$ 0.00	\$ 0.00	\$ 0.00	\$ 0.00	\$ 0.00	
Family Bingo	9/13/2026		\$ 0.00	\$ 0.00	\$ 0.00	\$ 0.00	\$ 0.00	
Game Night	9/18/2026		\$ 0.00	\$ 0.00	\$ 0.00	\$ 0.00	\$ 0.00	
Birdhouse Workshop	9/19/2026		\$ 0.00	\$ 0.00	\$ 0.00	\$ 0.00	\$ 0.00	
Water Sports	9/20/2026		\$ 0.00	\$ 0.00	\$ 0.00	\$ 0.00	\$ 0.00	
Fall Fishing Derby	9/25/2026		\$ 0.00	\$ 0.00	\$ 0.00	\$ 0.00	\$ 0.00	
Pickleball Tournament	9/26/2026		\$ 0.00	\$ 0.00	\$ 0.00	\$ 0.00	\$ 0.00	
Sunday Sundaes	9/27/2026		\$ 0.00	\$ 0.00	\$ 0.00	\$ 0.00	\$ 0.00	
Misc. Shopping for the Month	September		\$ -	\$ 0.00	\$ 0.00	\$ 0.00	\$ 0.00	
			\$ 1550.00	\$ 0.00	\$ 0.00	\$ 0.00	\$ 0.00	
Proposed Budget to Date			\$ 24,575.00	\$ 0.00	\$ 0.00	\$ 0.00	\$ 0.00	

Event Reconciliation October 1, 2025 - September 30, 2026

Yearly Budget	\$35,000	
<u>Year-To-Date Expenditures</u>	<u>\$21,453</u>	Does not include the storage unit fee of \$276.00 per month.

*Year-to-date includes deposits for upcoming events.



Pasco Sheriff's Office
 ATTN: Secondary Employment Office Administrator
 7432 Little Road
 New Port Richey, FL 34654

THE PRESERVE AT WILDERNESS LAKE CDD

The below is a consolidated daily report of all the deputies that worked the THE PRESERVE AT WL CDD* Community (Security) detail on 6/5/2026

Deputy: **SEIN CABAN, GABRIELA (7480)**
 Position: Community (Security)
 Scheduled Time 9:00PM - 1:00AM
 Actual Time 9:00PM - 1:00AM

Display Text	Answer Text1
Event Number:	2026343457
Who did you contact upon arrival?	Tish via PX
Number of field interview reports:	0
Number of parking tickets:	0
Amount of time running radar:	0
Were there any other types of violations, such as trespassing, written warnings, additional event numbers:	<p>Written warnings and violating warnings: 2026343593 (3 cars off of Citrus Blossom were observed parking in streets) 2026343582 (2 cars off Kickliter Ln were observed parking in streets) 2026343570 (single vehicle tagged off of Garden Walk Lp) 2026343563 (Single vehicle tagged off of Eleanor Wood Ct) 2026343555 (Single vehicle tagged off of Wilderness Lakes) *this individuals parent came out advising their daughter did not know better and corrected their parking.</p>



Pasco Sheriff's Office
ATTN: Secondary Employment Office Administrator
7432 Little Road
New Port Richey, FL 34654

Please document a detailed Narrative of events that took place during your detail:

Worked the detail from 2100 to 0100 hours. Observed numerous illegal parking violations, those who did not appear to have been warned before were provided with a Parking Violation Warning tag, appears an orange Jeep from the residence at 7650 Citrus Blossom Dr was provided with a warning and citation in the past for illegally parking, and was provided with another. Residence at 7048 Palmetto Pine Ln, appeared to be having a large gathering, causing large amount of vehicles parked on the street, and a large amount of vehicles off of Cormorant Cove have been parking on the streets as well. Vehicles at Palmetto were cleared out by the end of the detail. Multiple vehicles were provided with violations, one individual advised they were unaware and did correct their parking. Cleared the gym, pool, restrooms, and saunas at 2100 hours, no individuals were inside the building; however, juveniles advised they left their pickleball paddles inside, which I assisted in obtaining for them. Maintained a heavy presence in the community center area due to multiple vehicles going in and out of parking lot, with occasional patrolling throughout to monitor parking on streets.

Was the PSO manpower assigned to the detail sufficient? If no, please provide details and a recommendation for future details.

YES

List any facts, circumstances, or information Extra Duty Admin should be aware of if this detail becomes reoccurring.

None



Pasco Sheriff's Office
 ATTN: Secondary Employment Office Administrator
 7432 Little Road
 New Port Richey, FL 34654

THE PRESERVE AT WILDERNESS LAKE CDD

The below is a consolidated daily report of all the deputies that worked the THE PRESERVE AT WL CDD* Community (Security) detail on 6/6/2026

Deputy: **FITTS, DEREK (4982)**
 Position: Community (Security)
 Scheduled Time 10:00PM - 2:00AM
 Actual Time 10:00PM - 2:00AM

Display Text	Answer Text1
Event Number:	2026-345549
Who did you contact upon arrival?	Clubhouse staff
Number of field interview reports:	0
Number of parking tickets:	0
Amount of time running radar:	90mi
Were there any other types of violations, such as trespassing, written warnings, additional event numbers:	4 warning for street parking
Please document a detailed Narrative of events that took place during your detail:	The majority of the time was spent patrolling the clubhouse area and docks. There was a call at the exit of the community of potential vandalism in progress. Assist patrol in handling the call. I issued 4 warnings to vehicles parking in the street. I did not encounter anyone in the gym or clubhouse area after 2300 hours. There were no major incidents that occurred during this shift.
Was the PSO manpower assigned to the detail sufficient? If no, please provide details and a recommendation for future details.	YES
List any facts, circumstances, or information Extra Duty Admin should be aware of if this detail becomes reoccurring.	na



Pasco Sheriff's Office
 ATTN: Secondary Employment Office Administrator
 7432 Little Road
 New Port Richey, FL 34654

THE PRESERVE AT WILDERNESS LAKE CDD

The below is a consolidated daily report of all the deputies that worked the THE PRESERVE AT WL CDD* Community (Security) detail on 5/24/2026

Deputy: **RICHARDSON, LLOYD (7623)**
 Position: Community (Security)
 Scheduled Time 10:00PM - 2:00AM
 Actual Time 10:00PM - 2:00AM

Display Text	Answer Text1
Event Number:	2026316753
Who did you contact upon arrival?	I called Tish when I arrived.
Number of field interview reports:	None.
Number of parking tickets:	None.
Amount of time running radar:	None.
Were there any other types of violations, such as trespassing, written warnings, additional event numbers:	No.
Please document a detailed Narrative of events that took place during your detail:	I arrived at the location and made contact with Tish. I performed a vehicle patrol of the community and stopped by the guard booth to pick up the key to the gym. At 10:45 pm, I checked the gym including the bathrooms and saunas. I turned off lights and made sure the gym was clear by 11:00 pm. I continued to perform vehicle patrols of the community during my shift. A power outage lasted for about an hour that affected the community.
Was the PSO manpower assigned to the detail sufficient? If no, please provide details and a recommendation for future details.	YES
List any facts, circumstances, or information Extra Duty Admin should be aware of if this detail becomes reoccurring.	None at this time.



Pasco Sheriff's Office
 ATTN: Secondary Employment Office Administrator
 7432 Little Road
 New Port Richey, FL 34654

THE PRESERVE AT WILDERNESS LAKE CDD

The below is a consolidated daily report of all the deputies that worked the THE PRESERVE AT WL CDD* Community (Security) detail on 5/29/2026

Deputy: **VOGELE, KEVIN (7376)**
 Position: Community (Security)
 Scheduled Time 9:00PM - 1:00AM
 Actual Time 9:00PM - 11:30PM

Display Text	Answer Text1
Event Number:	2026328030
Who did you contact upon arrival?	Tish
Number of field interview reports:	NA
Number of parking tickets:	NA
Amount of time running radar:	2.5
Were there any other types of violations, such as trespassing, written warnings, additional event numbers:	NA
Please document a detailed Narrative of events that took place during your detail:	I provided police presence at the clubhouse as well as different locations throughout the neighborhood. I checked the gym and pool areas around 11pm when gym closed. I did not observe anyone at location and anyone suspicious throughout the shift.
Was the PSO manpower assigned to the detail sufficient? If no, please provide details and a recommendation for future details.	YES
List any facts, circumstances, or information Extra Duty Admin should be aware of if this detail becomes reoccurring.	NA



Pasco Sheriff's Office
ATTN: Secondary Employment Office Administrator
7432 Little Road
New Port Richey, FL 34654

THE PRESERVE AT WILDERNESS LAKE CDD

**The below is a consolidated daily report of all the deputies that worked the THE PRESERVE AT WL CDD*
Community (Security) detail on 5/30/2026**

Deputy: **GONZALEZ ZAPATA, OSCAR (7858)**

Position: Community (Security)

Scheduled Time 10:00PM - 2:00AM

Actual Time 10:00PM - 2:00AM

Display Text	Answer Text1
Event Number:	2026330092
Who did you contact upon arrival?	Tish and front desk employee.
Number of field interview reports:	N/A
Number of parking tickets:	N/A
Amount of time running radar:	0
Were there any other types of violations, such as trespassing, written warnings, additional event numbers:	intrusion alarm, under event number 2026330275 Traffic stop EVENT # 2026330372



Pasco Sheriff's Office
 ATTN: Secondary Employment Office Administrator
 7432 Little Road
 New Port Richey, FL 34654

Please document a detailed Narrative of events that took place during your detail:

On May 30th, 2026 at 2200 hours I arrive to 21320 Wilderness Lake Blvd, Land O' Lakes for and off duty detail. Upon arrival I made contact with the front desk employees at the club house, as well I informed Tish. I pick up the access key from the ranger house located at the entrance of the community.

2210 hours, I conducted direct patrol for traffic violators, conducted foot patrol around the commons area around the club house.

2300 hours, I conducted foot patrol on common areas, I closed the gym and advised residence it was closed.

0010 hours, I responded to a call for service, in reference to an intrusion alarm, under event number 2026330275,

0035 hours, I conducted foot patrol on common areas, and direct patrol for traffic violators.

0124 hours, I conducted a traffic stop EVENT # 2026330372. On a suspicious vehicle, bearing FL tag 72GDXF. Vehicle was first seen on Citrus Blossom, once they saw me they took off driving north to Blue Spring Dr. I lost visual of vehicle. I than observed the same vehicle park outside 7047 Palmetto Pines Ln. I made contact with 4 teenager under 16 years old, they stated they were here to pick up a W/M from a residence. I advised of Pasco County curfew Article V, chapter 66.153. After Traffic stop was completed they left the community. EVENT # 2026330372

Before I ended my detail I placed the card key back in the ranger station, lock the door, and placed the key back in the key lock. I completed a final direct patrol, for traffic violators.

NFA, BWC activated, OGZ7858

Was the PSO manpower assigned to the detail sufficient? If no, please provide details and a recommendation for future details.

YES

List any facts, circumstances, or information Extra Duty Admin should be aware of if this detail becomes reoccurring.

N/A



Pasco Sheriff's Office
 ATTN: Secondary Employment Office Administrator
 7432 Little Road
 New Port Richey, FL 34654

THE PRESERVE AT WILDERNESS LAKE CDD

The below is a consolidated daily report of all the deputies that worked the THE PRESERVE AT WL CDD* Community (Security) detail on 6/12/2026

Deputy: **FRANCIS, DAVID (7459)**
 Position: Community (Security)
 Scheduled Time 10:00PM - 2:00AM
 Actual Time 10:00PM - 2:00AM

Display Text	Answer Text1
Event Number:	2026359362
Who did you contact upon arrival?	Tish at 813-758-4841
Number of field interview reports:	None
Number of parking tickets:	4 parking citations 4 parking warnings
Amount of time running radar:	0
Were there any other types of violations, such as trespassing, written warnings, additional event numbers:	No other violations observed
Please document a detailed Narrative of events that took place during your detail:	2200 to 2330 hours: patrolled the clubhouse. 2330 to 0100 hours: patrolled the community to observe any violations. 0100 to 0200 hours: patrolled the clubhouse.
Was the PSO manpower assigned to the detail sufficient? If no, please provide details and a recommendation for future details.	YES
List any facts, circumstances, or information Extra Duty Admin should be aware of if this detail becomes reoccurring.	n/a



Pasco Sheriff's Office
 ATTN: Secondary Employment Office Administrator
 7432 Little Road
 New Port Richey, FL 34654

THE PRESERVE AT WILDERNESS LAKE CDD

The below is a consolidated daily report of all the deputies that worked the THE PRESERVE AT WL CDD* Community (Security) detail on 6/13/2026

Deputy: **KANOS, NICHOLAS (7617)**
 Position: Community (Security)
 Scheduled Time 11:00PM - 3:00AM
 Actual Time 11:00PM - 3:00AM

Display Text	Answer Text1
Event Number:	2026361269
Who did you contact upon arrival?	tish
Number of field interview reports:	N/A
Number of parking tickets:	2
Amount of time running radar:	2
Were there any other types of violations, such as trespassing, written warnings, additional event numbers:	N/A
Please document a detailed Narrative of events that took place during your detail:	Upon arrival conducted various patrols oh the neighborhood deterring crime. Conducted radar. gave parking violations to cars on following streets: grasmere dr cormorant cove dr
Was the PSO manpower assigned to the detail sufficient? If no, please provide details and a recommendation for future details.	YES
List any facts, circumstances, or information Extra Duty Admin should be aware of if this detail becomes reoccurring.	N/A



Pasco Sheriff's Office
 ATTN: Secondary Employment Office Administrator
 7432 Little Road
 New Port Richey, FL 34654

THE PRESERVE AT WILDERNESS LAKE CDD

The below is a consolidated daily report of all the deputies that worked the THE PRESERVE AT WL CDD* Community (Security) detail on 6/20/2026

Deputy: **KEENE, JUSTIN (5802)**
 Position: Community (Security)
 Scheduled Time 9:00PM - 1:00AM
 Actual Time 9:00PM - 1:00AM

Display Text	Answer Text1
Event Number:	2026376538
Who did you contact upon arrival?	employing party
Number of field interview reports:	0
Number of parking tickets:	0
Amount of time running radar:	0
Were there any other types of violations, such as trespassing, written warnings, additional event numbers:	0
Please document a detailed Narrative of events that took place during your detail:	Upon arrival, I checked in with lodge staff. I then conducted multiple patrols of the community maintaining a visible position. At approximately 2300 hours, I returned to the gym/amenities to verify they were empty. There was one occupant, however he left after being informed the gym was closing without incident. I did not observe anyone trespassing at any of the amenities after they had closed. No calls for service occurred within the community while on the detail. I did not observe any suspicious activity or traffic violations.
Was the PSO manpower assigned to the detail sufficient? If no, please provide details and a recommendation for future details.	YES
List any facts, circumstances, or information Extra Duty Admin should be aware of if this detail becomes reoccurring.	n/a

**Nail Salon Services Report
FY 2025-2026**

Month	Manicures	Pedicures	Commission Rcvd.	Residents	Non-residents
October	26	24	\$244.80	14	9
November	22	22	\$209.20	14	9
December	30	28	\$262.00	16	12
January	24	15	\$205.80	12	7
February	20	17	\$210.60	12	10
March	24	27	\$284.20	16	9
April	26	27	\$279.20	17	11
May	23	25	\$264.80	15	9
June	25	24	To be determined.	18	8
July					
August					
September					

Project Tracker

Current Projects

Date Entered	Project	Task	Update	Update	Estimated Completion Date
6/6/2025	Community fence line.	Repair & replace broken boards.	In progress.	Ongoing.	Ongoing.
7/3/2025	Repair and add rain gutters.	Secure proposals.	Received proposals from MD Gutters, Taylor Gardner Gutters, and 2nd Day Custom Carpentry & General Contracting.	The project was awarded to 2nd Day Custom Carpentry & General Contracting.	Commenced on 5/4/2026.
8/11/2025	Reupholster the Lodge sofa and arm chairs.	Secure a proposal from Walt's Upholstery.	Fabric selection completed. Proposal from Walt's Upholstery is forthcoming.	Deposit sent. The fireplace and the manager's office chairs were picked up.	Spring of 2026
1/8/2026	Remediate raised CDD owned sidewalks.	Mark and grind sidewalks.	Marking completed. Grinding in progress.	In progress.	Ongoing.
5/1/2026	Replace the Oakhurst/Woodsmere Park Pavilion.	Secure proposals to remove and replace the pavilion.	Approved the Site Master's of Florida proposal to remove the structure. Proposals to replace the pavilion are in progress. ARC - Received Project Innovations Florida Play structures	Site Masters removed the structure. Site Masters is preparing a proposal to replace the concrete slab.	September 2026
6/10/2026	Card access to the Men's Sauna.	Securing a proposal from A Total Solution and DCSI, Inc.			TBD
6/10/2026	Repair seven holes in Splash Pad rubber coating.	Contact Softroc for warranty repair.	Softroc confirmed the warranty is no longer valid. Specialty Surfaces is preparing a quote.	Proposal received. \$1,350.00 to repair the holes. \$3,150 to deep-clean and add a two-part urethane binder.	TBD

6/20/2026	Replace the Stoneleigh Park garden swing.	Secure proposals from Patio Land and Leaders Furniture.			TBD
-----------	---	---	--	--	-----

Potential Future Projects

Date Entered	Project	Task	Update 1	Update 2	Estimated Completion Date
8/15/2022	Storage Shed	Add a 10x16 shed in the empty maintenance yard.	Obtained 3 bids from area dealers. Received proposal from Site Masters to add a concrete slab to support the structure. Chuck from GHS has determined the area is good from a drainage perspective.	Directed to suspend activity for the time being, which would involve obtaining proposal for additional security camera and determining costs to insure the contents of the storage shed. Board must first determine whether this is a project they are even interested in first. Tabled at the Oct. & Nov. meeting.	Tabled
2/1/2023	Security Improvements	Add new security cameras to account for several (7) areas in the amenities areas and at the outer parks where we are currently blind.	Met with Convergent for initial consultation and then with DCSI for more specific recommendations as far as hardware is concerned. Proposal pending. Additional proposals forthcoming.	Received proposal from DCSI for new camera system with expanded capabilities beyond the 30 channels our current system provides. Awaiting proposal for the cameras.	Tabled
1/28/2023	Seasonal Security Patrols	Add professional security patrol services during the summer break period of 5/23 – 8/23.	Received multiple bids and presented to the Board at the March meeting. Advised to revisit the numbers and indicate where in the budget to draw that from, then come back present again at the April meeting. Numbers have been crunched and it is on the April Agenda.	On hold per the Board.	Tabled
2/26/2024	Community Garden	Seek Board approval to add a community garden in the overflow parking area.	In the designing stage.	On hold until there is funding.	On hold

3/10/2024	Add a shade structure & trees to the Citrus Blossom / Whispering Wind Park	Secure proposals for the shade canopy and trees.	Contacted Creative Shade Solutions, Inc. and RedTree.	On hold per the Board.	On hold
8/7/2024	Consider replacing fence line wood with composite material. (Phased plan)	Secure proposals for consideration.		Florida Reserve Study to provide life expectancy in updated Reserve Study.	FY 24/25
8/7/2024	Replace outdated playground equipment, as needed. Establish the remaining life of the neighborhood playground equipment. Inquire on safety upgrades and	Contacted Egis & Florida Reserve Study for an assessment/cost of assessment.		Florida Reserve Study to provide life expectancy in updated Reserve Study.	

Completed Projects

Date Entered	Project	Task	Update 1	Update 2	Completion Date
8/15/2022	Brick Pavers Repairs	Repair areas 4,5,7, and 9.	Areas 4 and 5 completed.	Completed.	7/1/2023
8/17/2022	Floating Dock	Dock has a long piece of wood coming separated.	Support column underneath dock has collapsed and is in immediate need of repair or replacement.	Floating dock to be replaced with new, including EZ dock launch, canoe paddle-on launch, canoe/kayak rack, and roof for kayak. Contract has been signed by all parties and the deposit has been sent in.	6/1/2023

8/22/2022	New signage for the Pools	Signs to be created by Cooper Pools to include specific language regarding water bottles and swim diapers.	Called for update on 8/23 and am awaiting a response.	Completed.	5/23/2023
12/16/2022	Gate Installation	To install new gate and chain link fence at the end of Grasmere Dr. which would allow for mowers to access the common area next to 7947 Grasmere Drive.	Board opted to go with a 6' PVC fence identical to the one currently seen across the street.	Completed.	3/23/2023
10/19/2022	Splash Pad at Pool Area	To repair underlying issues at the splash pad and to resurface once repairs are completed.	Project approved by Board and work is in progress.	Completed.	3/23/2023
12/1/2022	Markers for storm drains	To install "No Dumping" markers on every storm drain throughout the WLP community.	Proposal received and sent to District Management for review.	Completed.	3/23/2023
1/26/2023	Outdoor Trash Bins	Add three (3) new outdoor trash bins to amenities areas similar in style to what we currently have on hand.	Proposals submitted to District Management for Board consideration at the February meeting.	Completed.	7/1/2023
2/1/2023	Community Pressure Washing	Pressure wash and treat rust stains along common sidewalk areas throughout the community.	Proposal received.	Completed.	3/23/2023
3/1/2023	New Signage for Business Center	Add new signage at Lodge Business Center	Proposal executed 3/3/23	Completed.	3/23/2023
3/9/2023	Handicap Lift Chair	Replace actuator and hub assembly kit at Lagoon pool handicap chair lift	Proposal received 3/9 and sent to District Management for review.	Completed.	4/23/2023
5/1/2023	Fire/Burglary Monitoring Services	A Total Solutions to repair/replace damaged equipment.	Fire & Burg online & functioning as designed.	Completed.	7/1/2023
5/1/2023	Splash Pad Palm Tree Rings	Replace the rock around the Palm trees.		Completed.	7/3/2023

12/9/2022	Tennis Court Lights	To install new lights throughout the entire tennis facility.	Requested proposal on 12/9/22. Vendor given OK to address immediate needs on the tennis courts and replace like with like at an NTE of 2k.	Completed.	December 2023
8/1/2023	ADA Doors Nature Center	Add an ADA auto door to front and rear of building.	Proposal approved October 2023.	Completed.	12/13/2023
9/1/2023	Lodge Oak tree bed enhancement.	Landscape proposal and design under review during the October meeting.	New bench order is in progress.	Completed.	11/13/2023
12/1/2023	Poolside Umbrellas	Purchase replacement umbrellas.	Received four umbrellas.	Completed.	1/30/2024
12/1/2023	Poolside Shade Structures	Replace two poolside shade structures.	On order.	Completed.	3/15/2024
12/1/2023	Playground ADA Mulch	Secure multiple proposals to replace the Playground ADA mulch.		Completed.	3/1/2024
12/1/2023	Lodge Common Area Park Benches	Order two park benches for the new Magnolia bed.	Cost under consideration.	Completed.	June 2024
2/26/2024	Stoneleigh / Foxgrove Park Shade Canopy	Replace the shade canopy.	Securing proposals - 2/27/2024	Completed.	April 2024
3/25/2024	Replace the rope lighting on the Lodge and Cormorant Cove docks.	Order rope lighting and tracks.	Received the rope lighting.	Completed.	May 2024
8/8/2024	Consider replacing the Pickleball equipment with heavy duty equipment.	Researching options.		Completed.	Sept. 2024
3/15/2024	Add 3 planters to the pool deck. (2 in the center island & 1 by the shower.)	Secure pricing for the planters. Advise RedTree of the project.	On hold until there is funding.	Completed.	On hold

8/1/2024	Replace the Dumbbells		Approved the FitRev proposal.	Completed.	8/23/2024
8/1/2024	Purchase Kettlebells		Purchased.	Completed.	8/9/2024
10/2/2024	License plate reader cameras. (2)	Securing proposals from A Total Solution and DCSI, Inc.	Approved and ordered.	Completed.	12/1/2024
2/1/2025	Lodge playhouse rust.	Remove rust spots and repaint.		Completed.	February 2025
3/5/2025	Add additional security lighting.	Secure a proposal to add security lighting for the dumpster and maintenance yards.	Himes Electric revised the proposal within the approved threshold.	Completed.	April 2025
8/7/2024	Add Grass Carp to Bay Lake.	Secure the permit and order the Carp.	Coordinating the permit, the purchase and release date of the Grass Carp.	Completed.	5/5/2025
8/8/2024	Replace the center section of the Nature Center wicker sofa.	Securing a proposal from Leaders Furniture.	Met with Leaders on 8/23/24. Recommend replacing the cushions and fabric.	Completed.	4/30/2025
1/1/2025	Replace the Jon Boat.	Securing pricing. Reserve item.		Completed.	5/2/2025
2/13/2025	Replace 12 worn poolside chairs.	In progress. Reserve item.		Completed.	5/22/2025
4/1/2025	Activities Center wooden chairs.	Repaint the 16 wooden chairs in the Activities Center.	In progress with Walt's Upholstery.	Completed.	5/23/2025
4/1/2025	Lodge Ottoman	Reupholster the Ottoman.	In progress with Walt's Upholstery.	Completed.	5/23/2025
6/6/2025	Stormwater inlets	Assess and clean clogged stormwater inlets.	Pasco County is scheduled to clean the inlets on Wilderness Lake Blvd. from Whispering Wind Drive to Citrus Blossom Drive.	Completed.	7/14/2025
6/15/2025	Update the Microsoft 365 License and Lodge computers.		Purchased the license through CDW. Ideal Network Solutions assisted with updating the Lodge computers.	Completed.	7/17/2025

6/6/2025	Replace the corrugated boards on the communication boards.		Ordered magnetic boards and letters.	Completed.	Completed July 2025.
10/2/2024	Create a project wish list once the Reserve Study is completed.		The Reserve Study assessment is scheduled for 10/31/2024.	The assessment was completed on 10/31/2024. Project list is in progress through the budget season.	June 2025
7/23/2025	Maintenance the Kubota.	Florida Coast Equipment is scheduled to assess the Kubota the week of 7/27/2025.	The Kubota was repaired; however, it is scheduled for further assessment.	Completed.	8/2/2025
8/22/2025	Replace Fitness Center HVAC unit 2.	Schedule the replacement once the proposal is approved.	Proposal approved by the Chairperson on 8/22/2025	Completed.	8/25/2025
1/8/2026	Create a safety zone with reflective tape in front of all the indoor electrical panels.	Purchase reflective safety zone tape.		Completed.	January 2026
1/15/2026	Replace the Jacuzzi ADA chair motor.	Secure proposal from Cooper Pools.	Proposal submitted and approved.	Completed.	February 2026
2/23/2026	Repair the Nature Center HVAC system in the main building.	Cool Coast is tracing a refrigerant leak.		Completed.	February 2026
11/5/2025	Repair and reseal the parking lot.	Secure proposals.	Project awarded to Superior Sealers, LLC	Project to commence after the holidays.	March 2026
11/5/2025	Replace a speaker in the sound system of the Activities Center.	Purchase a new speaker.	Speaker scheduled to be replaced after the holidays.	Completed.	March 2026
2/23/2026	Replace the ADA chair actuator.		Scheduled for replacement on March 3rd.	Completed.	March 2026
3/15/2026	Replace poolside chairs (12).	Ordered from Leaders Furniture.		Completed.	March 2026
4/1//2026	Rewire one of the chandeliers in the Activities Center.	Scheduled repair the 3rd week of April.		Completed.	April 2026
4/10//2026	Replace worn windscreens on the Tennis Courts.	Ordered windscreens from Welch Tennis.		Completed.	April 2026

4/1/2026	Schedule a repair of the Splash Pad communication panel with the manufacturer.		The project was turned over to the Water Odyssey Production Manager. Waiting for a return call. 4/28/2026		Completed May 2026.
4/28/2026	Replace Pickleball systems, as needed.	Replace three umbrellas.	Ordered.		Completed May 2026.
4/1/2026	Replace Pickleball systems, as needed.	Order two new systems.	Ordered.	Received one replacement system the first week of April. The second system is scheduled to arrive April 29, 2026.	Completed May 2026.
5/12/2026	Replace three poolside umbrellas.	Ordered umbrellas through Leaders Furniture.			Completed June 2026.

Landscape Projects & Proposal Tracker

Project/Proposal Requested	Date Requested	Date Received	Date Approved	Completion Date
Landscape Enhancement Project	3/18/2024	9/26/2024 Revised January 2025	January 2025	Completed 6/2025
Replace the Magnolia in the Lakewood Retreat/WL Blvd. Center island. (Damaged in the vehicular accident.) Relocate	3/18/2024			Completed 2/2025
Remove one dead Pine tree at WL Blvd. and Kickliter Lane.	4/30/2024	6/7/2024		Awarded to Blue Line Tree Company. Completed July 2024.
Snag two dead Pine trees in the conservation area between the Groves and PWL. Trees may be hazardous to homes in the Groves. (7221 Cleopatra Drive)	4/30/2024	5/8/2024		Awarded to Blue Line Tree Company June 2024.
Add new stakes the Bottle Brush between the Lap Pool and Tennis Courts.	5/9/2024			Completed 8/21/2024
Pull dead Duranta at the tip of Osprey Point monument.	5/9/2024			Completed 12/5/2024
Remove three dead Palm trees at the Lodge.	5/9/2024			Awarded to Blue Line Tree Company. Completed July 2024.

Remove several dead Pines throughout the community.	5/9/2024 & 6/13/2024			Awarded to Blue Line Tree Company. Completed July 2024.
Snag two dead Pine trees in the conservation area between The Woods and PWL. The trees may be hazardous to homes in The Woods. (6833 Amanda Vista Circle)	5/16/2024	6/7/2024		Awarded to Stumped Up. Completed July 2024. Completed July 2024.
Snag two dead Pine trees in the conservation area between Tango Road (The Groves) and PWL.	6/6/2024			Awarded to Stumped Up. Completed July 2024. Completed July 2024.
Replace two dead Azaleas on the outbound lane of Water's Edge.	6/13/2024		Warranty work. Reminder during the July 2024, August, September, October, November, and December landscape inspections. 3/13/2025, 4/10/2025, 5/8/2025, 6/12/2025, 7/11/2025, 8/8/2025, 9/11,2025, 10/9/2025, 11/13/2025, 12/11/2025, 1/8/2026, 2/12/2026 3/12/2026 4/9/2026 5/14/2026	

Replace the Hollies behind the Lagoon Pool.	6/13/2024	6/28/2024		Trees removed. Proposals were reviewed. Requested revisions on 5/20/2025.
Consider removing the declining Birch trees on WL Blvd. in the Water's Edge bed.	6/13/2024	7/17/2024	September 2024	10/2024
Add additional Lilies on the inside of the Lodge playground split rail fence and close in a bed with turf.	6/13/2024	7/17/2024	December 2024	3/2025
Remove dead Palm tree behind the Fitness Center.	6/13/2024	7/3/2024		Awarded to Blue Line Tree Company. Completed July 2024.
Consider replacing the Jatropha at the roundabout.	7/11/2024			Bushes recovered.
Restake the Jatropha at the roundabout.	8/15/2024		September 2024	10/2024
Remove hazardous trees that fell during the hurricanes and trim broken branches.	9/27/2024 Hurricane Helene 10/9/2024 Hurricane Milton			12/1/2024, 3/2025, 6/2025, 7/2025
Remove hazardous trees that fell after the highwater receded. (Cormorant Cove dock)	12/12/2024	12/18/2024	12/18/2024	1/2025 Trees removed. Reminder of stump removal needed.

Mulch, turf replacement & warranty turf.	12/12/2024	1/5/2025	1/8/2025	7/3/2025
Basketball Court landscape project	1/9/2025, 4/2025, 6/2025, 7/2025, 8/2025 7/2025	Requested a revised plan/proposal	Requested a revised proposal. 1/20/2026 Sent	3/1/2026
Top dress the playgrounds with (ADA) mulch.	2/13/2025	3/28/2025	Project awarded to Southscapes Landscape Maintenance on 5/16/2025.	Completed 6/13/2025.
Requested proposal to remove the additional declining Hollies along the perimeter of the Lap pool and replace with Magnolias and Bottle Brush.	4/10/2025	Proposals were reviewed. Requested revisions on 5/20/2025.	On hold.	
Requested a proposal to remove a dead Palm Tree at Palmetto Pines.	4/10/2025	6/19/2025	6/19/2025	7/14/2025
Requested a proposal to remove five dead Pine trees between Stoneleigh Drive and Blue Spring Drive.	6/5/2025	6/19/2025	6/19/2025	7/14/2025
Requested a proposal to remove two dead Pine trees on Wilderness Lake Blvd.	6/5/2025	6/19/2025	6/19/2025	7/14/2025

Requested a proposal to remove storm debris from the natural area behind pond 5.	6/5/2025, 7/3/2025	7/29/2025	7/29/2025	8/10/2025
Requested a proposal to remove a dead pine near Wild Oak Lane, hazardous limbs at the corner of Timber Ridge Way, and three dead Pines at the Stoneleigh Park lift station.	6/5/2025, 7/3/2026	6/19/2025	6/19/2025	7/14/2025
Requested a proposal to remove a dead tree near Cypress Tree Court/Wilderness Lake Blvd.	6/5/2025, 7/3/2027	7/6/2025	7/6/2025	7/14/2025
Requested proposal to crown prune and thin 37 trees throughout the community.	6/5/2025, 7/3/2028	8/7/2025	8/6/2025	9/2/2025
Requested a proposal from RedTree and Blue Line Tree Company to remove several dead Pine trees on Wilderness Lake Blvd.	8/14/2025			9/2/2025
Requested a proposal to remove three Pine trees on WL Blvd.	9/11/2025	10/31/2025	10/31/2025	11/19/2025
Requested a proposals to remove two Cabbage Palms, One Oak tree and one Pine tree at the Heron's Wood monument.	9/11/2025, 9/23/2025, 10/9/2025, 10/21/2025	10/31/2025	10/31/2025	11/19/2025
Requested a proposal to remove low-hanging branches on the berm behind 7113 Derwent Glen Drive.	9/16/2025	1/6/2026		1/2026 - Blue Line completed the removal.
Requested a proposal to remove one Pine tree by the Maintenance Shed, three Pine trees at the Ranger's Station, and one Oak tree at the corner of Palmetto Pines.	9/11/2025, 9/23/2025, 10/9/2025, 10/21/2025	10/31/2025	10/31/2025	11/19/2025

Proposal to remove a dead tree on the pond bank behind 7651 Whispering Wind Drive.	10/21/2025			12/1/2025
Requested a revised proposal to remediate the center median at the entrance of the community.	11/4/2025	12/16/2025 1/20/2026 Sent revisions to RedTree.		3/2026
Requested a proposal to remove a dead Pine tree on the corner of Kickliter.	11/6/2025	11/6/2025	11/6/2025	11/19/2025
Requested a proposal to crown prune three Oak trees near the Tennis Courts and two in the Butterfly Garden, and remove one dead Pine tree on WL Blvd. and Quiet Haven Court.	11/12/2025	11/17/2025	11/17/2025	11/19/2025
Requested proposals from RedTree to remove low-hanging branches on the Derwent Glen and Moss Ledge Run berms and on Wilderness Lake Blvd/Citrus Blossom Drive, removal of 6-7 dead Pines on the Draycott berm, removal of dead Pines across from the Lodge and at the Ranger's Station, and removal of stumps throughout the community.	11/13/2025, 12/12/2025			Project awarded to Blue Line Tree Co. In progress.

<p>Requested proposals from Blue Line Tree Company and Sheffield's Quality Tree Services to remove low-hanging branches on the Derwent Glen and Moss Ledge Run berms and on Wilderness Lake Blvd/Citrus Blossom Drive, removal of 6-7 dead Pines on the Draycott berm, removal of dead Pines across from the Lodge and at the Ranger's Station, and removal of stumps throughout the community.</p>	<p>12/16/2025</p>	<p>12/18/2025 Received proposals from Blue Line Tree Co. & Sheffield's Quality Tree Service. 1/6/2026 Received proposals from RedTree.</p>		<p>Project awarded to Blue Line Tree Co. In progress.</p>
<p>Requested proposals for the following: Heron's Wood Monument: Add a Red Maple behind the monument. WL Blvd. Center Island Across from Woods Bay Court: Remove two dead Pine tree in the center island across from Woods Bay Court. Water's Edge: Remove the declining Red Maple on the inbound lane. WL Blvd. Center Island across from the Dunkin Donuts entrance: Remove the dead Pine tree.</p>	<p>1/8/2026 & 2/23/2026 - RedTree 2/9/2026 - Blue Line</p>	<p>2/13/2026 Only received the Red Maple proposal.</p>		<p>3/2026 - Red Maple Installed. 3/2026 - Blue Line removed the dead Pine trees.</p>
<p>Requested a proposal to hard prune the Crape Myrtle trees throughout the community from: RedTree Landscape Systems Blue Line Tree Company Sheffield's Quality Tree Service</p>	<p>2/9/2026</p>	<p>Proposals received.</p>		<p>3/2026 - Sheffields Quality Tree Service completed the project.</p>

Requested a proposal to remove a dead Pine at the corner of Citrus Blossom Drive & Wilderness Lake Blvd. from RedTree & Blue Line.	3/4/2026	Proposals received.		3/2026 - Blue Line completed the project.
Requested Milkweed for the Butterfly Garden.	3/12/2026			Completed by Staff.
Requested a proposal to replace the dead hedge between WL Blvd. and the irrigation pump.	3/12/2026	Proposal received.		5/14/2026
Requested a proposal to remove a dead Pine tree in the common area next to 7138 Kendall Heath Way.	3/12/2026	Proposal received.		5/5/2026
Requested a proposal to replace the declining hedge around the Splash Pad equipment.	3/12/2026	Proposal Received.		5/5/2026
Requested a proposal to replace a Palm tree in the center island on the pool deck.	3/12/2026	Proposal Received.		5/14/2026
Requested a proposal to remove two Pines in the common area between Endless Summer Court & Citrus Blossom Drive.	3/25/2026	Proposals received.		5/5/2026
Requested a proposal to remove two dead Pine trees on the Grasmere/Deerfields Berm - RedTree and Blue Line	3/27/2026	Received a proposal from Blue Line.		6/2/2026
Requested a proposal to remove two dead Pine trees in the common area behind 7919 Citrus Blossom Drive.	3/27/2026	Proposals received.		5/5/2026

Request for proposal from RedTree & Blue Line to lift an Oak tree branch encroaching on private property.	4/1/2026			6/2/2026
Requested a proposal to remove and replace a declining Ligustrum shrub on the pool deck.	4/9/2026	Proposal Received.		5/14/2026
Requested a proposal from RedTree and Blue Line to remove a dead Palm tree on the Jacuzzi deck.	4/9/2026	Received one combined proposal from RedTree to remove the Palm tree and replace it. Requested a revised proposal to separate the services.	Received a proposal from Blue Line.	6/2/2026
Request for Milkweed in the Butterfly Garden.	4/9/2026	2nd request.		5/26/2026
Requested weed and dead vegetation removal throughout the community.	5/14/2026 & 6/11/2026	In progress.		
Requested warranty install of 5 Azaleas at the Water's Edge outbound gate.	6/11/2026 & 6/18/2026			
Requested warranty install of Sweet Viburnum on the Wild Oak Hedge line.	6/11/2026			

Requested proposal to replace dead vegetation that succumbed to the frost and freeze damage.	6/11/2026	Met with Kevin Smith to assess the areas for replacement vegetation.		
--	-----------	--	--	--

EXHIBIT 5



powered by SmartLink Network®

Inspection #9

Date: Jun 10, 2026 9:33 am
 Inspector: Matthew Olson

Site	
Name	The Preserve at Wilderness Lake
Address	21330 Wilderness Lake Boulevard
City	Land O' Lakes
ST	Florida
Zip	34637

Controller	
Name	Dunkin
Location	
Model	
Modules	15
Controller ID	142466

Water Days as of Jun 10, 2026	
Program A	Tue , Thur , Sat
Program B	Mon , Wed , Fri
Program C	Mon , Thur
Program D	

	Location	Valve Status	Clogged Nozzle	Blocked Head	Broken Head	Raise Head	Lower Head	Broken Drip Micro Spray	Broken Lateral	Broken Main	Scope
1	S- between DD & 41	Pass									
2	R- DD side & annuals	Pass									
3	S- center island & exit side annuals	Pass									
4	S- 2nd center island	Pass									
5	S- guard shack	Pass									
6	S- west of eagles landing	Pass									
7	S- pine knot to eagles nest island	Pass									
Raised 4" sprays											
8	S- eagle's landing island, center island	Pass									
9	R- pine knot to north markers edge sign	Pass									
10	S- East eagles landing to markers & island	Pass									
11	R- pine knot island rear	Pass									
12	R- in eagles landing	Pass									

	Location	Valve Status	Clogged Nozzle	Blocked Head	Broken Head	Raise Head	Loer Head	Broken Drip Micro Spray	Broken Lateral	Broken Main	Scope
13	R- pine knot island front	Pass									
14	R- ranger station-	Pass									
15	R - Eagles nest -Ranger ststion	Pass									
16	R- lift station-41	Pass									
17	No zone	Pass									
18		Pass									
19		Pass									
20		Pass									
21		Pass									
22		Pass									
23		Pass									
24		Pass									
25		Pass									
26		Pass									
27		Pass									
28		Pass									
29		Pass									
30		Pass									

Zone #1 - 06-10-26 9:34 am CDT



Zone #2 - 06-10-26 9:36 am CDT



Zone #3 - 06-10-26 9:38 am CDT



Zone #3 - 06-10-26 9:39 am CDT



Zone #4 - 06-10-26 9:43 am CDT



Zone #4 - 06-10-26 9:43 am CDT



Zone #4 - 06-10-26 9:44 am CDT



Zone #4 - 06-10-26 9:44 am CDT

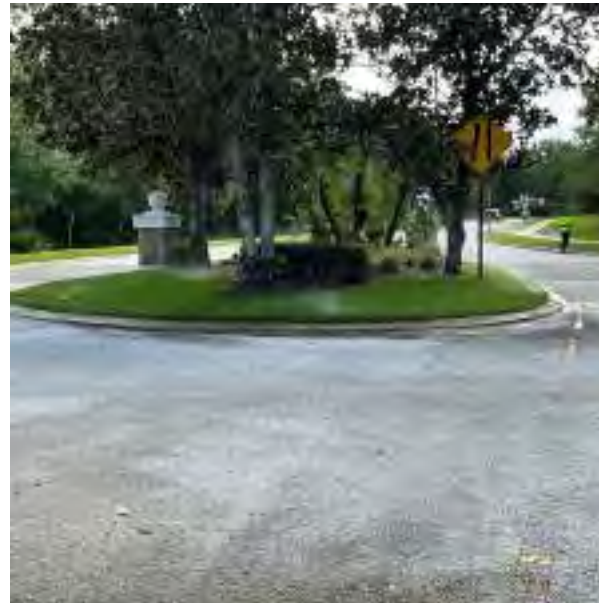

Zone #5 - 06-10-26 9:47 am CDT



Zone #6 - 06-10-26 9:50 am CDT



Zone #6 - 06-10-26 9:50 am CDT



Zone #6 - 06-10-26 9:50 am CDT



Zone #7 - 06-10-26 9:54 am CDT



Zone #8 - 06-10-26 9:58 am CDT

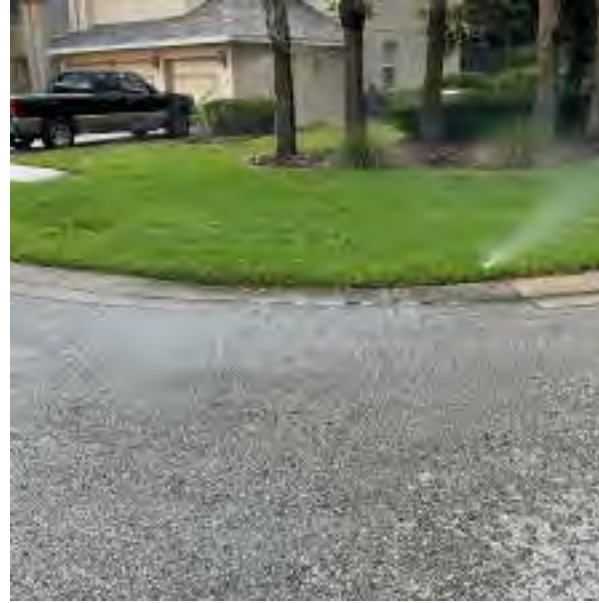

Zone #8 - 06-10-26 9:59 am CDT



Zone #9 - 06-10-26 10:00 am CDT



Zone #10 - 06-10-26 10:02 am CDT



Zone #10 - 06-10-26 10:02 am CDT



Zone #11 - 06-10-26 10:24 am CDT



Zone #11 - 06-10-26 10:25 am CDT



Zone #11 - 06-10-26 10:25 am CDT



Zone #12 - 06-10-26 10:32 am CDT



Zone #12 - 06-10-26 10:32 am CDT



Zone #13 - 06-10-26 10:39 am CDT



Zone #13 - 06-10-26 10:40 am CDT



Zone #13 - 06-10-26 10:40 am CDT



Zone #13 - 06-10-26 10:41 am CDT



Zone #14 - 06-10-26 10:57 am CDT



Zone #15 - 06-10-26 11:01 am CDT



Zone #16 - 06-10-26 11:17 am CDT





powered by SmartLink Network®

June 2026

Date: Jun 10, 2026 12:49 pm
 Inspector: Matthew Olson

Site	
Name	The Preserve at Wilderness Lake
Address	21330 Wilderness Lake Boulevard
City	Land O' Lakes
ST	Florida
Zip	34637

Controller	
Name	Waters edge
Location	
Model	
Modules	10
SLW	SLW1
Controller ID	142467

Water Days as of Jun 10, 2026	
Program A	Mon , Wed , Fri
Program B	Tue , Thur , Sat
Program C	Every day of the week
Program D	

	Location	Valve Status	Clogged Nozzle	Blocked Head	Broken Head	Raise Head	Lower Head	Broken Drip Micro Spray	Broken Lateral	Broken Main	Scope
1	R- both sides of waters edge entry	Pass									
2	S- waters edge to birchom court	Pass									
3	R- eagle crest long Island	Pass									
4	R- eagle crest island both sides of birchum	Pass									
5	S- west of lift station	Pass									
6	S- east of lift station	Pass									
7	S- west of nature ridge and 2 islands	Pass									
8	S/R- natures ridge both sides 8/11/25	Pass									
9	S- east of natures ridge	Pass									
10	D- behind food fence	Pass									
11	R- east of quail trace	Pass									
12	R- across from lodge	Pass									
13	S- island by lodge and both sides osprey point	Pass									

	Location	Valve Status	Clogged Nozzle	Blocked Head	Broken Head	Raise Head	Lower Head	Broken Drip Micro Spray	Broken Lateral	Broken Main	Scope
14	S- island by tennis court and quail trace	Pass									
15	R- quail trace to hawk pond 8/11/25	Pass									
16	S- eagles patch to hawk pond	Pass									
17	R- west of eagle patch 8/11/25	Pass									
1 broken head.											
18	R- west of eagle patch behind fence	Pass									
19	R- across from controller 8/11/25	Pass									
20	Not working- drip by osprey	Pass									
21		Pass									

Zone #1 - 06-10-26 12:51 pm CDT



Zone #1 - 06-10-26 12:52 pm CDT



Zone #1 - 06-10-26 12:52 pm CDT



Zone #2 - 06-10-26 1:02 pm CDT



Zone #3 - 06-10-26 1:04 pm CDT



Zone #3 - 06-10-26 1:04 pm CDT



Zone #4 - 06-10-26 1:07 pm CDT



Zone #4 - 06-10-26 1:08 pm CDT

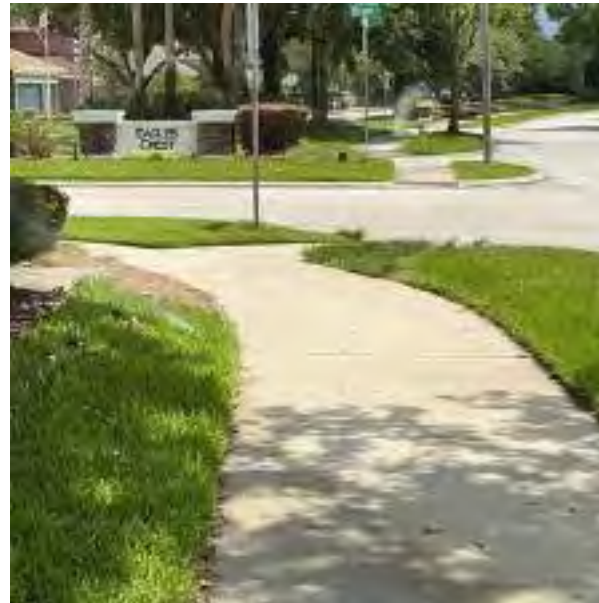

Zone #5 - 06-10-26 1:11 pm CDT

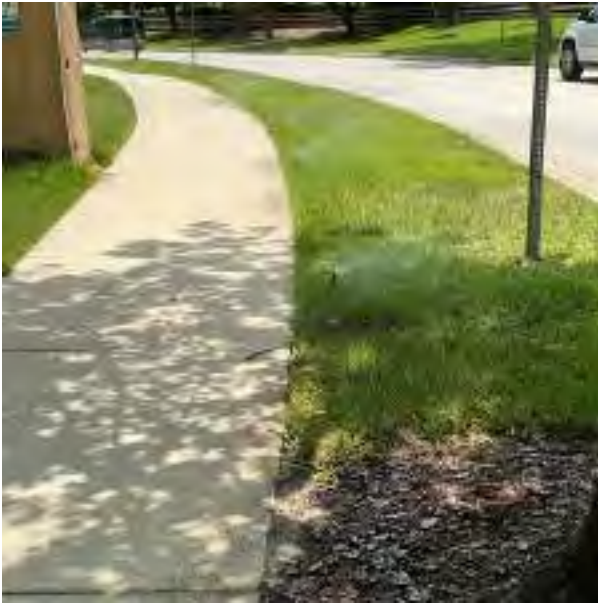

Zone #6 - 06-10-26 1:15 pm CDT

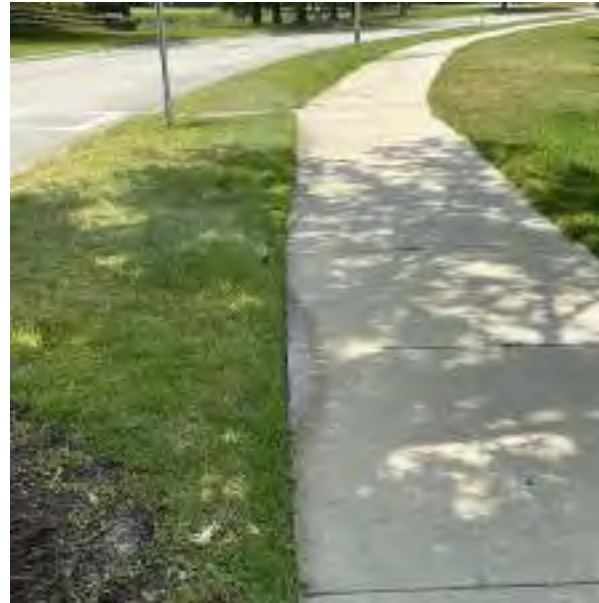

Zone #6 - 06-10-26 1:16 pm CDT



Zone #6 - 06-10-26 1:16 pm CDT



Zone #7 - 06-10-26 1:24 pm CDT



Zone #7 - 06-10-26 1:24 pm CDT



Zone #8 - 06-10-26 1:28 pm CDT



Zone #9 - 06-10-26 1:29 pm CDT



Zone #9 - 06-10-26 1:29 pm CDT



Zone #10 - 06-10-26 1:30 pm CDT



Zone #11 - 06-10-26 1:34 pm CDT



Zone #11 - 06-10-26 1:34 pm CDT



Zone #11 - 06-10-26 1:36 pm CDT



Zone #12 - 06-10-26 1:39 pm CDT



Zone #13 - 06-10-26 1:42 pm CDT

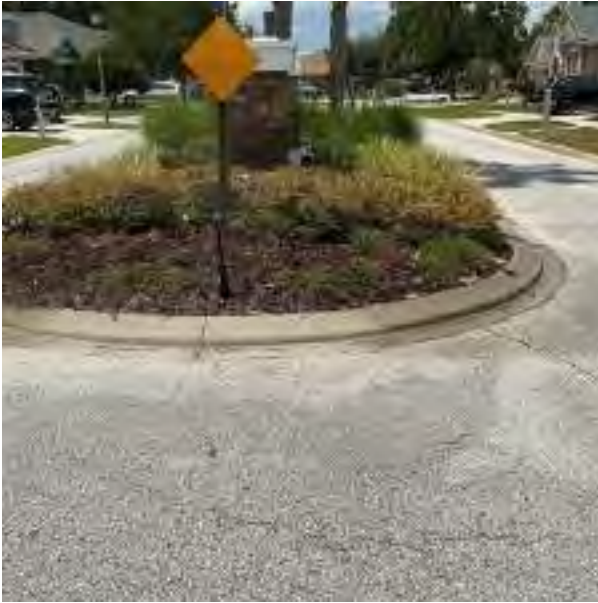

Zone #13 - 06-10-26 1:42 pm CDT



Zone #14 - 06-10-26 1:44 pm CDT



Zone #14 - 06-10-26 1:44 pm CDT



Zone #14 - 06-10-26 1:44 pm CDT



Zone #15 - 06-10-26 1:47 pm CDT



Zone #15 - 06-10-26 1:47 pm CDT



Zone #16 - 06-10-26 1:50 pm CDT



Zone #16 - 06-10-26 1:50 pm CDT



Zone #16 - 06-10-26 1:51 pm CDT



Zone #17 - 06-10-26 1:53 pm CDT



Zone #17 - 06-10-26 1:53 pm CDT



Zone #18 - 06-10-26 1:56 pm CDT



Zone #18 - 06-10-26 1:57 pm CDT



Zone #19 - 06-10-26 2:00 pm CDT



Zone #19 - 06-10-26 2:00 pm CDT





powered by SmartLink Network®

June 2026

Date: Jun 10, 2026 9:33 am
 Inspector: Matthew Olson

Site	
Name	The Preserve at Wilderness Lake
Address	21330 Wilderness Lake Boulevard
City	Land O' Lakes
ST	Florida
Zip	34637

Controller	
Name	Dunkin
Location	
Model	
Modules	15
Controller ID	142466

Water Days as of Jun 10, 2026	
Program A	Tue , Thur , Sat
Program B	Mon , Wed , Fri
Program C	Mon , Thur
Program D	

	Location	Valve Status	Clogged Nozzle	Blocked Head	Broken Head	Raise Head	Lower Head	Broken Drip Micro Spray	Broken Lateral	Broken Main	Scope
1	S- between DD & 41	Pass									
2	R- DD side & annuals	Pass									
3	S- center island & exit side annuals	Pass									
4	S- 2nd center island	Pass									
5	S- guard shack	Pass									
6	S- west of eagles landing	Pass									
7	S- pine knot to eagles nest island	Pass									
Raised 4" sprays											
8	S- eagle's landing island, center island	Pass									
9	R- pine knot to north markers edge sign	Pass									
10	S- East eagles landing to markers & island	Pass									
11	R- pine knot island rear	Pass									
12	R- in eagles landing	Pass									

	Location	Valve Status	Clogged Nozzle	Blocked Head	Broken Head	Raise Head	Lo□er Head	Broken Drip Micro Spray	Broken Lateral	Broken Main	Scope
13	R- pine knot island front	Pass									
14	R- ranger station-	Pass									
15	R - Eagles nest -Ranger ststion	Pass									
16	R- lift station-41	Pass									
17	No zone	Pass									
18		Pass									
19		Pass									
20		Pass									
21		Pass									
22		Pass									
23		Pass									
24		Pass									
25		Pass									
26		Pass									
27		Pass									
28		Pass									
29		Pass									
30		Pass									

Zone #1 - 06-10-26 9:34 am CDT



Zone #2 - 06-10-26 9:36 am CDT



Zone #3 - 06-10-26 9:38 am CDT



Zone #3 - 06-10-26 9:39 am CDT



Zone #4 - 06-10-26 9:43 am CDT



Zone #4 - 06-10-26 9:43 am CDT



Zone #4 - 06-10-26 9:44 am CDT



Zone #4 - 06-10-26 9:44 am CDT

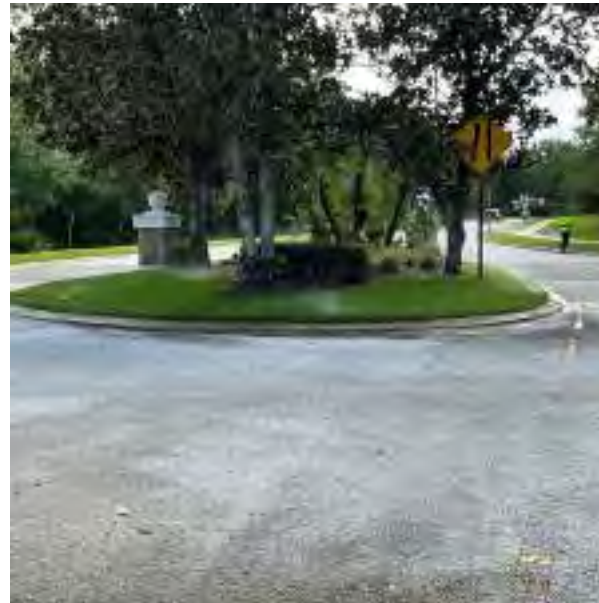

Zone #5 - 06-10-26 9:47 am CDT



Zone #6 - 06-10-26 9:50 am CDT



Zone #6 - 06-10-26 9:50 am CDT



Zone #6 - 06-10-26 9:50 am CDT



Zone #7 - 06-10-26 9:54 am CDT



Zone #8 - 06-10-26 9:58 am CDT

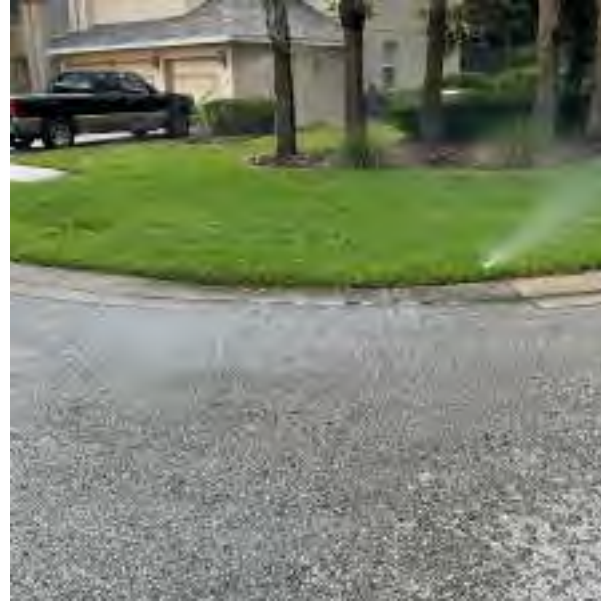

Zone #8 - 06-10-26 9:59 am CDT



Zone #9 - 06-10-26 10:00 am CDT



Zone #10 - 06-10-26 10:02 am CDT



Zone #10 - 06-10-26 10:02 am CDT



Zone #11 - 06-10-26 10:24 am CDT



Zone #11 - 06-10-26 10:25 am CDT



Zone #11 - 06-10-26 10:25 am CDT



Zone #12 - 06-10-26 10:32 am CDT



Zone #12 - 06-10-26 10:32 am CDT



Zone #13 - 06-10-26 10:39 am CDT



Zone #13 - 06-10-26 10:40 am CDT



Zone #13 - 06-10-26 10:40 am CDT



Zone #13 - 06-10-26 10:41 am CDT



Zone #14 - 06-10-26 10:57 am CDT



Zone #15 - 06-10-26 11:01 am CDT



Zone #16 - 06-10-26 11:17 am CDT





powered by SmartLink Network®

May 2026

Date: May 05, 2026 12:41 pm
 Inspector: Jose Soto

Site	
Name	The Preserve at Wilderness Lake
Address	21330 Wilderness Lake Boulevard
City	Land O' Lakes
ST	Florida
Zip	34637

Controller	
Name	Heron Wood BOT
Location	
Model	
Modules	2
Controller ID	148064

Water Days as of May 05, 2026	
Program A	Mon , Fri
Program B	
Program C	
Program D	

	Location	Valve Status	Clogged Nozzle	Blocked Head	Broken Head	Raise Head	Looper Head	Broken Drip Micro Spray	Broken Lateral	Broken Main	Scope
1	R- front of sign	Pass									
2	S- road	Pass									
3	R- behind sign	Pass									
4		Pass									

Zone #1 - 05-06-26 12:46 pm CDT



Zone #2 - 05-06-26 12:47 pm CDT



Zone #3 - 05-06-26 12:48 pm CDT



Zone #4 - 05-06-26 12:48 pm CDT





powered by SmartLink Network®

May 2026

Date: May 27, 2026 11:57 am
Inspector: Jose Soto

Site	
Name	The Preserve at Wilderness Lake
Address	21330 Wilderness Lake Boulevard
City	Land O' Lakes
ST	Florida
Zip	34637

Controller	
Name	Dunkin
Location	
Model	
Modules	15
Controller ID	142466

Water Days as of May 27, 2026	
Program A	Tue , Thur , Sat
Program B	Mon , Wed , Fri
Program C	Mon , Thur
Program D	

	Location	Valve Status	Clogged Nozzle	Blocked Head	Broken Head	Raise Head	Lower Head	Broken Drip Micro Spray	Broken Lateral	Broken Main	Scope
1	S- between DD & 41	Pass									
2	R- DD side & annuals	Pass									
3	S- center island & exit side annuals	Pass									
4	S- 2nd center island	Pass									
5	S- guard shack	Pass									
6	S- west of eagles landing	Pass									
7	S- pine knot to eagles nest island	Pass									
8	S- eagle's landing island, center island	Pass									
9	R- pine knot to north markers edge sign	Pass									
10	S- East eagles landing to markers & island	Pass									
11	R- pine knot island rear	Pass									
12	R- in eagles landing	Pass									
13	R- pine knot island front	Pass									

	Location	Valve Status	Clogged Nozzle	Blocked Head	Broken Head	Raise Head	Loer Head	Broken Drip Micro Spray	Broken Lateral	Broken Main	Scope
14	R- ranger station-	Pass									
15	R - Eagles nest -Ranger ststion	Pass									
16	R- lift station-41	Pass									
17	No zone	Pass									
18		Pass									
19		Pass									
20		Pass									
21		Pass									
22		Pass									
23		Pass									
24		Pass									
25		Pass									
26		Pass									
27		Pass									
28		Pass									
29		Pass									
30		Pass									

Zone #1 - 05-27-26 12:01 pm CDT



Zone #2 - 05-27-26 12:04 pm CDT



Zone #3 - 05-27-26 12:08 pm CDT



Zone #4 - 05-27-26 12:08 pm CDT



Zone #5 - 05-27-26 12:11 pm CDT



Zone #6 - 05-27-26 12:17 pm CDT



Zone #7 - 05-27-26 12:30 pm CDT



Zone #8 - 05-27-26 12:33 pm CDT



Zone #9 - 05-27-26 12:33 pm CDT



Zone #10 - 05-27-26 12:34 pm CDT



Zone #11 - 05-27-26 12:34 pm CDT



Zone #12 - 05-27-26 12:34 pm CDT



Zone #13 - 05-27-26 12:34 pm CDT



Zone #14 - 05-27-26 12:34 pm CDT



Zone #15 - 05-27-26 12:34 pm CDT





powered by SmartLink Network®

May 2026

Date: May 20, 2026 12:08 pm
 Inspector: Jose Soto

Site	
Name	The Preserve at Wilderness Lake
Address	21330 Wilderness Lake Boulevard
City	Land O' Lakes
ST	Florida
Zip	34637

Controller	
Name	Volley Ball Court
Location	
Model	
Modules	5
SLW	SLW1
Controller ID	142450

Water Days as of May 20, 2026	
Program A	Mon , Wed , Fri
Program B	
Program C	
Program D	

	Location	Valve Status	Clogged Nozzle	Blocked Head	Broken Head	Raise Head	Lower Head	Broken Drip Micro Spray	Broken Lateral	Broken Main	Scope
1	R- In Field	Pass									
2	S-Side Walk & Road North	Pass									
3	R-In Field	Pass									
4	S-Side Walk & Road North	Pass									
5	R-In Field	Pass									
6		Pass									
7		Pass									
8		Pass									
9		Pass									
10		Pass									

Zone #1 - 05-20-26 12:09 pm CDT



Zone #2 - 05-20-26 12:10 pm CDT



Zone #3 - 05-20-26 12:10 pm CDT



Zone #4 - 05-20-26 12:11 pm CDT



Zone #5 - 05-20-26 12:12 pm CDT





powered by SmartLink Network®

May 2026

Date: May 14, 2026 7:56 am
Inspector: Jose Soto

Site	
Name	The Preserve at Wilderness Lake
Address	21330 Wilderness Lake Boulevard
City	Land O' Lakes
ST	Florida
Zip	34637

Controller	
Name	Lodge
Location	
Model	
Modules	12
Controller ID	142447

Water Days as of May 14, 2026	
Program A	Mon , Wed , Fri
Program B	Tue , Thur , Sat
Program C	Mon , Wed , Fri
Program D	Sun

	Location	Valve Status	Clogged Nozzle	Blocked Head	Broken Head	Raise Head	Looper Head	Broken Drip Micro Spray	Broken Lateral	Broken Main	Scope
1	S-Tennis Court	Pass									
2	R-Back Tennis Court Near Pump	Pass									
3	S-Pool/Sidealk	Pass									
4	R/S- Back Field To Mailbox	Pass									
5	R/S-Parking/Wilderness Dr to Jasmine	Pass									
6	S-Parking Island	Pass									
7	R-Basketball to Dock	Pass									
8	S/MJ- Ann. L Lodge Conference Bld	Pass									
9	R/MJ-Ann. L Lodge	Pass									
10	M-Butter Fly Garden Along Pool	Pass									
11	D/MJ-Pots Pool & Gym	Pass									
12	N/A	Pass									
13	S-Sidealk/Island to Natures Way	Pass									

	Location	Valve Status	Clogged Nozzle	Blocked Head	Broken Head	Raise Head	Lo ^o er Head	Broken Drip Micro Spray	Broken Lateral	Broken Main	Scope
14	R&S- clubhouse island	Pass									
15		Pass									
16		Pass									
17		Pass									
18		Pass									
19		Pass									
20		Pass									
21		Pass									
22		Pass									
23		Pass									
24		Pass									
25		Pass									

Zone #1 - 05-13-26 8:11 am CDT



Zone #2 - 05-13-26 8:13 am CDT



Zone #4 - 05-13-26 8:15 am CDT



Zone #5 - 05-13-26 8:17 am CDT



Zone #6 - 05-13-26 8:20 am CDT



Zone #7 - 05-13-26 8:25 am CDT



Zone #8 - 05-13-26 7:58 am CDT



Zone #9 - 05-13-26 8:27 am CDT



Zone #10 - 05-13-26 8:29 am CDT



Zone #10 - 05-13-26 8:30 am CDT



Zone #11 - 05-13-26 7:57 am CDT



Zone #14 - 05-13-26 8:05 am CDT





powered by SmartLink Network®

May 2026

Date: May 13, 2026 12:17 pm
 Inspector: Jose Soto

Site	
Name	The Preserve at Wilderness Lake
Address	21330 Wilderness Lake Boulevard
City	Land O' Lakes
ST	Florida
Zip	34637

Controller	
Name	Heron Wood BOT
Location	
Model	
Modules	2
Controller ID	148064

Water Days as of May 13, 2026	
Program A	Mon , Fri
Program B	
Program C	
Program D	

	Location	Valve Status	Clogged Nozzle	Blocked Head	Broken Head	Raise Head	Looper Head	Broken Drip Micro Spray	Broken Lateral	Broken Main	Scope
1	R- front of sign	Pass									
2	S- road	Pass									
3	R- behind sign	Pass									
4		Pass									

Zone #1 - 05-13-26 12:18 pm CDT



Zone #2 - 05-13-26 12:20 pm CDT



Zone #3 - 05-13-26 12:21 pm CDT





powered by SmartLink Network®

May 2026

Date: May 13, 2026 12:09 pm
 Inspector: Jose Soto

Site	
Name	The Preserve at Wilderness Lake
Address	21330 Wilderness Lake Boulevard
City	Land O' Lakes
ST	Florida
Zip	34637

Controller	
Name	Neighborhood Park
Location	
Model	
Modules	5
Controller ID	142451

Water Days as of May 13, 2026	
Program A	Mon , Wed , Fri
Program B	
Program C	
Program D	

	Location	Valve Status	Clogged Nozzle	Blocked Head	Broken Head	Raise Head	Lower Head	Broken Drip Micro Spray	Broken Lateral	Broken Main	Scope
1	S-S Curb strip	Pass									
2	S Front Controller/Curb Strip	Pass									
3	R-Field Along Sidewalk	Pass									
4	R- In Park	Pass									
5	R- In Field	Pass									
6	R-Along Fence	Pass									
7	R-In Field	Pass									
8	S-Outside Of Park	Pass									
9	R-In Park	Pass									
10	R-In Park	Pass									

Zone #1 - 05-13-26 12:09 pm CDT



Zone #2 - 05-13-26 12:10 pm CDT



Zone #3 - 05-13-26 12:11 pm CDT



Zone #4 - 05-13-26 12:11 pm CDT



Zone #5 - 05-13-26 12:12 pm CDT



Zone #6 - 05-13-26 12:12 pm CDT



Zone #7 - 05-13-26 12:13 pm CDT



Zone #8 - 05-13-26 12:14 pm CDT



Zone #9 - 05-13-26 12:15 pm CDT



Zone #10 - 05-13-26 12:16 pm CDT





powered by SmartLink Network®

May 2026

Date: May 13, 2026 9:43 am
 Inspector: Jose Soto

Site	
Name	The Preserve at Wilderness Lake
Address	21330 Wilderness Lake Boulevard
City	Land O' Lakes
ST	Florida
Zip	34637

Controller	
Name	Sparrowood
Location	
Model	
Modules	7
Controller ID	142468

Water Days as of May 13, 2026	
Program A	Mon , Wed , Fri
Program B	
Program C	
Program D	

	Location	Valve Status	Clogged Nozzle	Blocked Head	Broken Head	Raise Head	Lower Head	Broken Drip Micro Spray	Broken Lateral	Broken Main	Scope
1	R-	Pass									
2	R-	Pass									
3	R-	Pass									
4	R-	Pass									
5	S-	Pass									
6	R-	Pass									
7		Pass									
8		Pass									
9		Pass									
10		Pass									
11		Pass									
12		Pass									
13		Pass									

	Location	Valve Status	Clogged Nozzle	Blocked Head	Broken Head	Raise Head	Lo ^o er Head	Broken Drip Micro Spray	Broken Lateral	Broken Main	Scope
14		Pass									

Zone #1 - 05-13-26 9:44 am CDT



Zone #2 - 05-13-26 9:45 am CDT



Zone #3 - 05-13-26 9:46 am CDT



Zone #4 - 05-13-26 9:47 am CDT



Zone #5 - 05-13-26 9:48 am CDT



Zone #7 - 05-13-26 9:52 am CDT



Zone #8 - 05-13-26 9:54 am CDT



Zone #9 - 05-13-26 10:06 am CDT



Zone #10 - 05-13-26 10:09 am CDT



Zone #11 - 05-13-26 10:09 am CDT



Zone #12 - 05-13-26 10:10 am CDT



Zone #13 - 05-13-26 10:13 am CDT



Zone #14 - 05-13-26 10:16 am CDT





powered by SmartLink Network®

May 2026

Date: May 13, 2026 9:13 am
 Inspector: Jose Soto

Site	
Name	The Preserve at Wilderness Lake
Address	21330 Wilderness Lake Boulevard
City	Land O' Lakes
ST	Florida
Zip	34637

Controller	
Name	Volley Ball Court
Location	
Model	
Modules	5
SLW	SLW1
Controller ID	142450

Water Days as of May 13, 2026	
Program A	Mon , Wed , Fri
Program B	
Program C	
Program D	

	Location	Valve Status	Clogged Nozzle	Blocked Head	Broken Head	Raise Head	Lower Head	Broken Drip Micro Spray	Broken Lateral	Broken Main	Scope
1	R- In Field	Pass									
2	S-Side Walk & Road North	Pass									
3	R-In Field	Pass									
4	S-Side Walk & Road North	Pass									
5	R-In Field	Pass									
6		Pass									
7		Pass									
8		Pass									
9		Pass									
10		Pass									

Zone #1 - 05-13-26 9:13 am CDT



Zone #2 - 05-13-26 9:14 am CDT



Zone #3 - 05-13-26 9:14 am CDT



Zone #4 - 05-13-26 9:15 am CDT



Zone #5 - 05-13-26 9:16 am CDT





powered by SmartLink Network®

May 2026

Date: May 13, 2026 7:46 am
Inspector: Jose Soto

Site	
Name	The Preserve at Wilderness Lake
Address	21330 Wilderness Lake Boulevard
City	Land O' Lakes
ST	Florida
Zip	34637

Controller	
Name	Lodge
Location	
Model	
Modules	12
Controller ID	142447

Water Days as of May 13, 2026	
Program A	Mon , Wed , Fri
Program B	Tue , Thur , Sat
Program C	Mon , Wed , Fri
Program D	Sun

	Location	Valve Status	Clogged Nozzle	Blocked Head	Broken Head	Raise Head	Looper Head	Broken Drip Micro Spray	Broken Lateral	Broken Main	Scope
1	S-Tennis Court	Pass									
2	R-Back Tennis Court Near Pump	Pass									
3	S-Pool/Sidealk	Pass									
4	R/S- Back Field To Mailbox	Pass									
5	R/S-Parking/Wilderness Dr to Jasmine	Pass									
6	S-Parking Island	Pass									
7	R-Basketball to Dock	Pass									
8	S/MJ- Ann. L Lodge Conference Bld	Pass									
9	R/MJ-Ann. L Lodge	Pass									
10	M-Butter Fly Garden Along Pool	Pass									
11	D/MJ-Pots Pool & Gym	Pass									
12	N/A	Pass									
13	S-Sidealk/Island to Natures Way	Pass									

	Location	Valve Status	Clogged Nozzle	Blocked Head	Broken Head	Raise Head	Lo ^o er Head	Broken Drip Micro Spray	Broken Lateral	Broken Main	Scope
14	R&S- clubhouse island	Pass									
15		Pass									
16		Pass									
17		Pass									
18		Pass									
19		Pass									
20		Pass									
21		Pass									
22		Pass									
23		Pass									
24		Pass									
25		Pass									

Zone #11 - 05-13-26 7:51 am CDT





powered by SmartLink Network®

May 2026

Date: May 13, 2026 7:34 am
 Inspector: Jose Soto

Site	
Name	The Preserve at Wilderness Lake
Address	21330 Wilderness Lake Boulevard
City	Land O' Lakes
ST	Florida
Zip	34637

Controller	
Name	Back Flo Near House 7700
Location	Node 400 Near House 7700
Model	
Modules	2
Controller ID	142452

Water Days as of May 13, 2026	
Program A	
Program B	
Program C	
Program D	

	Location	Valve Status	Clogged Nozzle	Blocked Head	Broken Head	Raise Head	Looser Head	Broken Drip Micro Spray	Broken Lateral	Broken Main	Scope
1	S- Curb Strip	Pass									
2	R-W Half Sign	Pass									
3	R-E Half Sign	Pass									
4		Pass									
5		Pass									

Zone #1 - 05-13-26 7:34 am CDT



Zone #2 - 05-13-26 7:35 am CDT



Zone #3 - 05-13-26 7:36 am CDT



Zone #4 - 05-13-26 7:37 am CDT





powered by SmartLink Network®

May 2026

Date: May 06, 2026 1:04 pm
 Inspector: Jose Soto

Site	
Name	The Preserve at Wilderness Lake
Address	21330 Wilderness Lake Boulevard
City	Land O' Lakes
ST	Florida
Zip	34637

Controller	
Name	Volley Ball Court
Location	
Model	
Modules	5
SLW	SLW1
Controller ID	142450

Water Days as of May 06, 2026	
Program A	Mon , Wed , Fri
Program B	
Program C	
Program D	

	Location	Valve Status	Clogged Nozzle	Blocked Head	Broken Head	Raise Head	Lower Head	Broken Drip Micro Spray	Broken Lateral	Broken Main	Scope
1	R- In Field	Pass									
2	S-Side Walk & Road North	Pass									
3	R-In Field	Pass									
4	S-Side Walk & Road North	Pass									
5	R-In Field	Pass									
6		Pass									
7		Pass									
8		Pass									
9		Pass									
10		Pass									

Zone #1 - 05-06-26 1:07 pm CDT



Zone #2 - 05-06-26 1:08 pm CDT



Zone #3 - 05-06-26 1:08 pm CDT



Zone #4 - 05-06-26 1:09 pm CDT



Zone #5 - 05-06-26 1:09 pm CDT





powered by SmartLink Network®

May 2026

Date: May 06, 2026 10:28 am
 Inspector: Jose Soto

Site	
Name	The Preserve at Wilderness Lake
Address	21330 Wilderness Lake Boulevard
City	Land O' Lakes
ST	Florida
Zip	34637

Controller	
Name	Heron Food BOT
Location	
Model	
Modules	2
Controller ID	148064

Water Days as of May 06, 2026	
Program A	Mon , Fri
Program B	
Program C	
Program D	

	Location	Valve Status	Clogged Nozzle	Blocked Head	Broken Head	Raise Head	Lower Head	Broken Drip Micro Spray	Broken Lateral	Broken Main	Scope
1	R- front of sign	Pass									
2	S- road	Pass									
3	R- behind sign	Pass									
4		Pass									

Zone #1 - 05-06-26 10:29 am CDT



Zone #2 - 05-06-26 10:29 am CDT



Zone #3 - 05-06-26 10:30 am CDT





powered by SmartLink Network®

May 2026

Date: May 06, 2026 8:22 am
 Inspector: Jose Soto

Site	
Name	The Preserve at Wilderness Lake
Address	21330 Wilderness Lake Boulevard
City	Land O' Lakes
ST	Florida
Zip	34637

Controller	
Name	Caliente
Location	
Model	
Modules	19
Controller ID	142448

Water Days as of May 06, 2026	
Program A	Mon , Wed , Fri
Program B	
Program C	
Program D	

	Location	Valve Status	Clogged Nozzle	Blocked Head	Broken Head	Raise Head	Lower Head	Broken Drip Micro Spray	Broken Lateral	Broken Main	Scope
1	R-Well Turf both sides	Pass									
2	R-E Field Along Hedges	Pass									
3	R- E field Center	Pass									
4	R-Caliente E Field	Pass									
5	D-Hedge Line S Park	Pass									
6	R-Woodsmere/Oakhurst & Lift Station	Pass									
7	R-S/E Corner Park	Pass									
8	R-Center Park	Pass									
9		Pass									
10		Pass									
11		Pass									
12		Pass									
13		Pass									

	Location	Valve Status	Clogged Nozzle	Blocked Head	Broken Head	Raise Head	Loer Head	Broken Drip Micro Spray	Broken Lateral	Broken Main	Scope
14		Pass									
15		Pass									
16		Pass									
17	S-/ Night Herion/ C/Islands	Pass									
18	S-Park/Sidealk	Pass									
19	S-Near Lift Station	Pass									
20	R-Caliente & Night Herion	Pass									
21	R-Park Near Sing	Pass									
22	D-hedge ro	Pass									
23	D-hedge ro	Pass									
24	M/ Exit side	Pass									
25	M/ Wilderness exit	Pass									
26		Pass									
27		Pass									
28		Pass									
29		Pass									
30		Pass									
31		Pass									
32		Pass									
33		Pass									
34		Pass									
35		Pass									
36		Pass									
37		Pass									
38		Pass									

Zone #1 - 05-06-26 8:23 am CDT



Zone #2 - 05-06-26 8:23 am CDT



Zone #3 - 05-06-26 8:24 am CDT



Zone #4 - 05-06-26 8:30 am CDT



Zone #5 - 05-06-26 8:32 am CDT



Zone #6 - 05-06-26 8:32 am CDT



Zone #7 - 05-06-26 8:33 am CDT



Zone #8 - 05-06-26 8:40 am CDT



Zone #17 - 05-06-26 8:43 am CDT



Zone #18 - 05-06-26 8:44 am CDT



Zone #19 - 05-06-26 8:49 am CDT



Zone #20 - 05-06-26 8:52 am CDT



Zone #21 - 05-06-26 8:56 am CDT



Zone #22 - 05-06-26 9:02 am CDT



Zone #23 - 05-06-26 9:02 am CDT



Zone #24 - 05-06-26 9:03 am CDT



Zone #25 - 05-06-26 9:07 am CDT



EXHIBIT 6

PSA HORTICULTURAL

Landscape Consulting & Contract Management
“Protecting Your Landscape Investment”

8431 Prestwick Place
Trinity, FL 34655

LANDSCAPE INSPECTION RESULTS

Date:	June 11, 2026
Client:	Preserve at Wilderness Lake Community Development District
Attended by:	CDD Management- Tish Dobson (Vesta Property Services) RedTree Landscape Systems-Lesly PSA Horticultural-Tom Picciano

This landscape inspection report and subsequent ones will serve as both a benchmark of current landscape maintenance concerns and the progress toward corrective actions. It will also serve as a deficiency list of items that should be addressed under the current landscape agreement.

These items must be completed by June 30, 2026. Notify PSA in writing upon their completion, via fax or email, on or before 9 am on July 1, 2026. The contractor must initial the bottom of each page and sign at the bottom of the last page. The reason for any uncompleted deficiency must be noted.

SCORE 1-POOR 2-FAIR 3-GOOD

3 MOWING/EDGING/TRIMMING

Minnow Brook-line trim along wood line. Treat invasive grass with Roundup.

Ambleside cul-de-sac- turf needs to be mowed around pond and behind control structure. *Photo below.*



The mowing was not yet completed for the week, but it was in progress. The cut was at the proper height. The hard and soft edging were performed correctly, and the cleanup of hard surfaces was thorough. There were no issues regarding the mowing operation.

3 WOOD LINE MAINTENANCE

Water's Edge entry side split rail fence- cut back vines growing up oak tree as well as encroaching vegetation directly across the street. *Photo below.*



Wood lines were neatly maintained.

3 TURF COLOR

Boulevard from Lodge to main entry-turf color still ranged from a lightly mottled medium green to a consistent medium green.

Citrus Blossom Park common area- turf color was a consistent medium green.

Citrus Blossom playground- turf color was a consistent medium green

Stoneleigh Park-turf color of the common Bermudagrass was a mottled medium green. The St. Augustine turf color remained a consistent dark green.

Lodge- turf color still ranged from a lightly mottled medium green to a consistent dark green.

Oakhurst Park- turf color of the common Bermudagrass ranged from a pale mottled green to a mottled medium green. The St. Augustine turf color remained a consistent dark green.

Kendall Heath/Waverly Shores- turf color of the common Bermudagrass was a pale mottled green. The St. Augustine turf color remained a consistent medium green.

Night Heron/Caliente intersection-turf color remained a lightly mottled medium green.

Roundabout- turf color ranged from a consistent medium green to a consistent dark green.

Common area Bahiagrass- turf color was a lightly mottled medium green and will continue to darken with the summer rainfall.

June



June



June

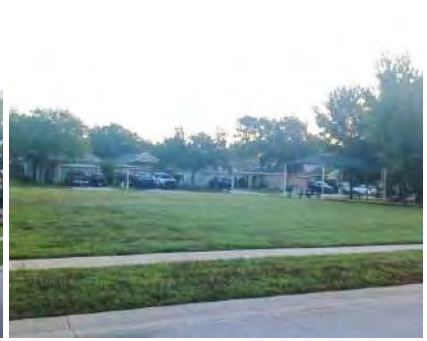

June



May



May



May



April



April



March



March



March



3 TURF DENSITY

Kendall Heath/Waverly Shores-the density of the common Bermudagrass was fair. The common Bermudagrass would benefit from a yearly overseeding program. The density of the St. Augustine turf was good.

Boulevard from Lodge to main entry-the density still ranged from fair to good. Most turf panels had a strong density. The areas by the outbound ranger station have improved.

Citrus Blossom Park-the density was strong.

Citrus Blossom common area-the density was strong.

Stoneleigh Park-the density of the common Bermudagrass was strong. The density of the St. Augustine turf remained strong.

Oakhurst Park- the density of the common Bermudagrass ranged from poor to fair. There was a slight improvement over the past month. The common Bermudagrass field would benefit from a yearly overseeding program. The density of the St. Augustine turf remained strong.

Night Heron/Caliente intersection-the density was strong as weed growth is being reduced.

Lodge-most of the density of the main entry lawn, front lawn, nature center lawn and rear lawn remained strong.

Tennis court-the density remained strong.

Common area Bahiagrass- the density was strong. Rainfall is improving the density.

Common area sidewalk parkway and center median by roundabout-the density was strong.

2 TURF WEED CONTROL

There was an increase in weed volume over the past month.

Pine Knot - treat broadleaf weeds.

Boulevard outbound from bridge to traffic light- treat broadleaf weeds.

Americus-treat broadleaf weeds.

Boulevard across from Draycott-treat broadleaf weeds.

Boulevard inbound and outbound from bridge to lodge-treat broadleaf weeds in parkway strip.

Lodge right side-treat increase in goose grass volume in compacted soil along bed line.

Oakhurst Park-evidence of weed dieback from herbicide application. *Photo below.*



2 TURF INSECT/DISEASE CONTROL/OVERALL HEALTH

Remove pesticide placards.

Oakhurst Park- turf health in the soccer field ranged from poor to fair. Overseeding yearly would help to improve the quality of this lawn.

Boulevard outbound at ranger station- turf health is improving.

Eagles Crest Monument at Birchholm- weak section of turf has begun to fill in with turf runners and weeds. Do not treat for weeds until St. Augustine turf health and density can sustain a herbicide application.

The turf was mowed at the correct height. The color and density of the St. Augustine was strong in most locations. The common Bermudagrass was performing better at Stoneleigh Park than at Oakhurst Park. The Bahiagrass is actively growing now that the summer rain has arrived. Disease and insect activity appear to be under control. Continue to monitor disease activity, particularly take all rot, and treat accordingly. The weeds volume has increased. Weeds should be treated in the cooler temperatures of morning to reduce the chance of damage to turf.

2 SHRUB-TREE INSECT/DISEASE CONTROL/OVERALL HEALTH

Many of the winter damaged plants such as natal plum and jatropha have been very slow to recover. Some may need to be replaced if significant growth is not achieved.

Oak Grove monument - submit a proposal to replace all winter damaged plants.

Stoneleigh cul-de-sac- submit a proposal to remove leaning tree.

Wild Oak- replace newly installed viburnum that have died. 7-gallon size is recommended. **WARRANTY WORK.** *Photo below.*



Wild Oak- Roundup damage to bed line and shrubs. Both will recover. Non-selective herbicide applications need to be more precise. *Photo below*



Water's Edge exit drive- 5 azaleas need to be installed. **WARRANTY WORK.**

Boulevard inbound at Dunkin' Donuts and pediatric office -recommended that due to the invasive nature of the wedelia and the fact that it's growing away from the sidewalk it is recommended that a flax lily or a similar plant be installed along the split rail fence.

Waverly Shores / Kendall Heath common area at 21922 – submit a proposal to remove leaning pine tree between common area and home.

Minnow Brook median- treat cotton cushion scale on the ornamental grasses. *Photo below.*



Lodge left front corner - remove winter damaged jatropa along short brick path and replace.

Splash pad area- remove declining winter damaged arboricola and two duranta and replace with copper leaf. *Photo below.*



Pool deck along butterfly garden- remove dead azalea.

Pool gate – red plant large pot. *Photo below.*



Lodge parking lot along Boulevard- flush cut declining crape myrtles at the end of azalea bed. *Photo below*



Butterfly garden- newly installed philodendron, bromeliads and shell ginger are performing well and have increased in size. *Photo below.*



Lodge patio- remove dead jatropha.

Eagles Crest Monument- treat Fakahatchee grass for spider mite.

Water's Edge center median- recommend removal of large ligustrum tree. It affects turn around. *Photo below*



Boulevard at Kickliter- treat Fakahatchee grass for spider mites.

Quail Trace monument- remove dead plant.

Herons Wood monument- remove dead plant.

3 BED / CRACK WEED CONTROL

Kendall Heath cul-de-sac - spray air potato along wood line.

Boulevard bridge - remove bed weeds and vines from podocarpus hedge.

West side of tennis court closer to Boulevard fence- cut large vine growing up pine tree.

Clubhouse right front corner Azalea bed- remove bed weeds. *Photo below.*



West side of tennis court- remove vines along split rail fence in palmetto bed.

2 IRRIGATION MANAGEMENT

Pool deck - increase run times to newly installed viburnum at pool equipment and add maxi jets.

Nature's Ridge entry drive sidewalk - repair irrigation leak along inside of sidewalk.

Oakhurst Park at the corner of Kendall Heath and Night Heron as well as Night Heron at lift station along parkway- Turf is dry at both areas.

Lodge exit drive berm- re-attach and straighten rotor on standpipe. *Photo below.*



Lodge entry drive- monitor the irrigation to newly installed viburnum. Some of the plants are drying out. Add maxi-jets. *Photo below.*



Deerfields entry parkway-turf is dry.

Caliente at Night Heron-sections of turf are dry. Some of this is also herbicide stressed turf which will recover. *Photo below.*



3 SHRUB PRUNING

*It should be noted that the shrubs, including but not limited to, the hawthorns and schilling hollies, should not be pruned too tightly. This means that too much vegetative growth was being removed, limiting the plants availability to make food for itself. In addition, the plant will look more attractive by not having “holes” in it and allowing it to develop its more natural shape. (i.e. Indian Hawthorn has a natural mounded habit)

Waters Edge entry drive- tip back jasmine along sidewalk.

Lodge exit drive berm- cut back all dead sections of jatrophas down to the areas that are flushing out. *Photo below.*



Lodge patio pool gate -prune dead sections out of top of copperleaf.

Lodge parking lot along boulevard- prune dead sections out of azaleas. *Photo below.*



Front of nature center- lightly tip back larger azaleas. Maintain a loose informal shape. *Photo below.*



Rear of amenity center- prune Japanese blueberry away from lamppost.

Draycott cul de sac-viburnum hedge was neatly pruned. *Photo below*

April



May



June



3 TREE PRUNING

Boulevard at Woods Bay - elevate oak tree over sidewalk.

Cormorant Cove dock- remove low growth on sycamore to the left of dock ramp.

Waters Edge stop sign - elevate tree on corner.

Stoneleigh playground- elevate oak tree by garbage can at corner of playground edging.

Lodge left side - lightly prune red maple branch that is facing the parking lot to balance tree.

Lodge playground- elevate oak tree along split rail fence.

3 CLEANUP/RUBBISH REMOVAL

Stoneleigh cul-de-sac- remove vegetative debris in bed along PVC fence.

There was not a significant amount of litter or vegetative debris that needed to be removed.

N/A APPEARANCE OF SEASONAL COLOR

The new seasonal flower display of pentas was in the process of being installed. Only the bed in front of the lodge was planted. The plants were healthy and properly spaced. This component was not measured do to the fact that all beds were not yet planted. *Photo below.*

June



(0) CARRIED FORWARD FROM PRIOR MONTH

INSPECTION SCORE 35 of 39–PASSED INSPECTION. Passing score was 32 of 36 or 30 of 36 (w/o flowers). Payment for June services should be released after receiving the DONE REPORT.

FOR MANAGER

NEW Oak Grove monument - submit a proposal to replace all winter damaged plants.

NEW Stoneleigh cul-de-sac- submit a proposal to remove leaning tree.

NEW Boulevard inbound at Dunkin' Donuts and pediatric office -recommended that due to the invasive nature of the wedelia and the fact that it's growing away from the sidewalk it is recommended that a proposal be submitted to install flax lilies or a similar plant be installed along the split rail fence.

NEW Waverly Shores / Kendall Heath common area at 21922 – submit a proposal to remove leaning pine tree between common area and home.

Amenity center rear along patio-submit proposal to remove old thryallis and add jatropa and firebush.

Nature's Ridge entry drive- submit proposal to add two more lorapetalum.

SUMMARY

RedTree performed to contractual standards for this inspection. The mowing operation was being properly performed. The color and density of most turf panels and varieties ranged from fair to good. At this point there did not appear to be any significant insect or disease activity. Continue to monitor for take all rot and other summertime diseases. The broadleaf weed volume increased over the past month. Attention needs to be paid to the health of shrubs. Woodlines were well maintained. Shrub and tree pruning appeared to be following the specifications. Bed weed management was good. The new flower rotation of pentas was in the process of being installed. The plants were healthy and properly spaced where they had been planted.

RedTree Landscape Systems certifies that all work on this list has been completed in the 14-day timeframe specified in the contractual agreement and provided to PSA within the same period.

Signature _____

Print Name _____

Company _____

Date _____

5 Section Schedule

- 1.** Lodge, Kickliter, 2 Medians in front of the Lodge
- 2.** Draycott, Round-about, Deerfield Berm, Small Hedge, Cul-de-sac
- 3.** Cormorant Cove, Derwent Glen, Oakhurst, Woodsmeere, Sparrow Wood
- 4.** Front Entrance to Water's Edge - (Outbound lane), Including Wood Line
- 5.** Americus - Citrus Blossom, CB/WW Park, Stoneleigh Park, Volleyball Park

Bed Map Notes

Thin Saw Palmettos - Bi-monthly
Trim Mulhy Grass - Early summer - Other grasses every other month
Trim back Palm Trees - Mid-Oct. & early summer
Hedges & Weeds - Monthly
Lift tree limbs in winter - As needed in the summer
Deadhead flowers. Keep pots & boxes fresh & healthy - As needed
Clean beds. remove leaves. keep mulch defined, remove moss - Monthly
Pencil lip Cape Myrtles - As needed
Keep overhanging limbs on wood line set back. Line trim wood line - Monthly

EXHIBIT C

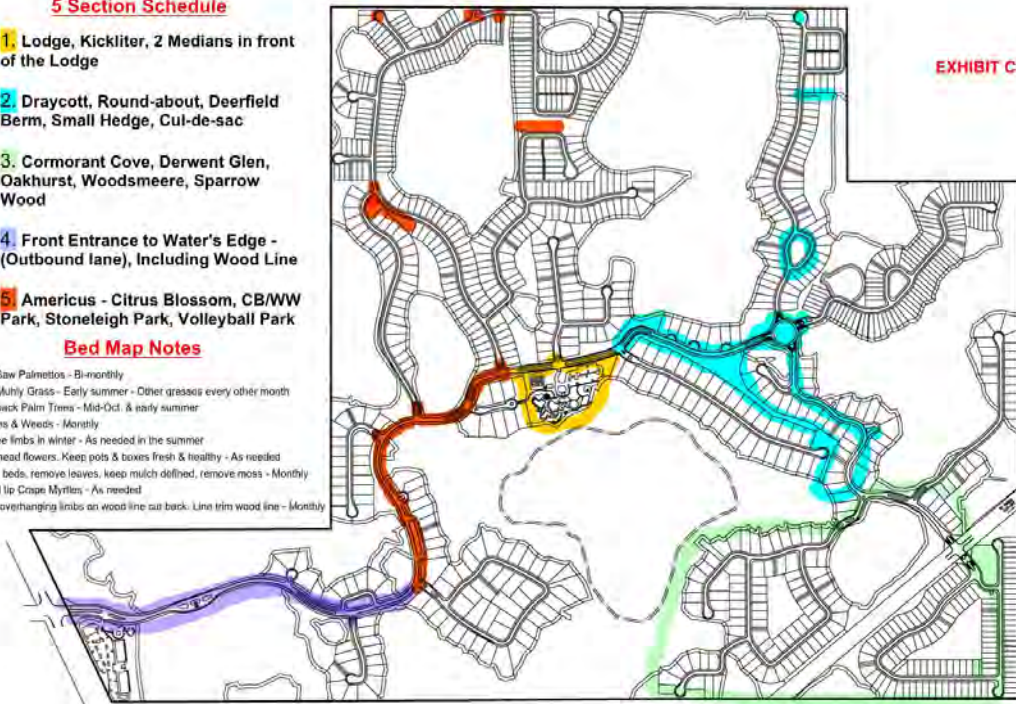

EXHIBIT 7

1 **MINUTES OF MEETING**
2 **PRESERVE AT WILDERNESS LAKE**
3 **COMMUNITY DEVELOPMENT DISTRICT**

4 The Regular Meeting of the Board of Supervisors of the Preserve at Wilderness Lake Community
5 Development District was held on Wednesday, June 10, 2026 at 6:32 p.m. at the Preserve at Wilderness
6 Lake Lodge, 21320 Wilderness Lake Boulevard, Land O' Lakes, FL 34637.

7 **FIRST ORDER OF BUSINESS – Call to Order/Roll Call**

8 Ms. Dobson called the meeting to order and conducted roll call.

9 Present and constituting a quorum were:

10	Heather Hepner	Board Supervisor, Chairwoman
11	John Staples	Board Supervisor, Vice Chairman
12	Beth Edwards	Board Supervisor, Assistant Secretary
13	Aga Fisher	Board Supervisor, Assistant Secretary
14	Holly Ruhlig	Board Supervisor, Assistant Secretary

15 Also present were:

16	Tish Dobson	District Manager, Vesta District Services
17	Cari Allen Webster (<i>via phone</i>)	District Counsel, Straley Robin Vericker
18	Pete Lucadano	RedTree Landscaping

19 *The following is a summary of the discussions and actions taken at the June 10, 2026 Preserve at Wilderness*
20 *Lake CDD Board of Supervisors Regular Meeting.*

21 **SECOND ORDER OF BUSINESS – Pledge of Allegiance**

22 Ms. Hepner led all present in the Pledge of Allegiance.

23 **THIRD ORDER OF BUSINESS – Audience Comments –** (*limited to 3 minutes per individual for agenda*
24 *items*)

25 There being none, the next item followed.

26 **FOURTH ORDER OF BUSINESS – Exhibit 1: Presentation of Proof of Publication(s)**

27 **FIFTH ORDER OF BUSINESS – Supervisor Comments**

28 There being none, the next item followed.

29 **SIXTH ORDER OF BUSINESS – Staff Reports**

30 A. Aquatic Services

31 1. Exhibit 2: GHS Environmental Report

32 Ms. Dobson provided an overview of the report and the ongoing work with the identified
33 maintenance areas. In response to Board questions, Ms. Dobson noted that remaining areas
34 included parts of Area 5, all of 6, and Areas 9-12, and stated that she would touch base
35 with them regarding the status of Whispering Wind vegetation, which was indicated as a
36 priority area.

37 Ms. Dobson and the Board also discussed the recent removal of an alligator from the dock
38 that had been repeatedly going after fishing bait. Pasco County's policy on eliminating
39 captured alligators in excess of five feet in length was discussed.

40

41 B. Exhibit 3: District Engineer

42 Ms. Dobson noted that there had been issues with the slope and angle of the gutters at their initial
43 installation state, and that these were now in the process of being reinstalled with additional fascia
44 replacement at no additional cost.

45 Ms. Dobson also discussed the replacement of the shade structure at Oakhurst/Woodsmere due to
46 welds failing and noted that the proposal from Site Masters for the removal of the metal framing
47 had been approved to occur prior to the end of the following week. Ms. Dobson suggested that the
48 existing concrete slab would need replacement due to cracking, but that the two quotes received
49 thus far were significantly high. Ms. Dobson and the Board discussed efforts to price out
50 components of the replacement, and the Board requested for an eblast to be distributed to the
51 community along with an article included in the newsletter to provide context for the project.

52 Ms. Dobson additionally gave an update on the North parcel development, explaining that the
53 County's list had yet to be completed.

54 C. District Counsel

55 Ms. Webster stated that she had nothing specific to report but was available to answer any of the
56 Board's questions or requests. Ms. Dobson noted that she had reached out to Counsel for
57 clarification regarding the HOA shared irrigation agreement, as several nozzles appeared to have
58 been rotated away from the vegetation, and discussed communications from JDI, the HOA's
59 irrigation vendor. Additional comments were made regarding schedules for system inspections, and
60 the CDD's plans to send the HOA invoices for repairs from the gate to the end of the shared
61 landscaping.

62 D. Exhibit 4: Community & District Manager, & Field Operations Report

63 Ms. Dobson provided the report, noting that the Kubota's engine had failed and that it may be more
64 advantageous to trade in for a new warrantied Kubota in the amount of \$13,993.92 as an engine
65 replacement estimate was given in the amount of \$10,341. Ms. Dobson noted that the necessary
66 funds could be pulled from reserves.

67 Ms. Ruhlig made a motion to approve the purchase of the new Kubota with warranty.

68 During discussion of the motion, comments were made expressing concerns with the accuracy of
69 the reserve study estimate, and the Board discussed potential financing/lease options for the
70 Kubota. Ms. Dobson noted that the CDD typically bought equipment outright rather than leasing,
71 with the exception of some large copying equipment for when the newsletter was printed in-house.

72 On a MOTION by Ms. Ruhlig, SECONDED by Mr. Staples, WITH ALL IN FAVOR, the Board approved
73 the purchase of a new Kubota with warranty, in the amount of \$13,993.92, for the Preserve at Wilderness
74 Lake Community Development District.

75 Following the motion, Ms. Dobson stated that she would reach out to Florida Coast Equipment for
76 the new Kubota, and that this would be fitted with the specialty tires that were on the current
77 Kubota.

78 Ms. Dobson and the Board discussed a specific chalk material used for art on playground
79 equipment, the little ranger station house, and the sidewalk near the tennis courts that had baked
80 into the surfaces and posed some difficulties in cleaning. The Board suggested putting out
81 communications requesting that this type of chalk product not be used.

82 Additional discussion ensued regarding an incident with the men's sauna rocks that had
83 necessitated its closure for multiple days for maintenance to clean and properly sanitize. Comments
84 were heard regarding the cost for remediation compared to the cost of installing a card reader as a

85 potentially preventative measure. Ms. Dobson stated that she could look into pricing and secure a
86 proposal to add the reader.

87 Ms. Dobson commented on the state of the splash pad, noting that the rubber coating in certain
88 areas had worn bare but that the pad itself was still functional. The Board and Ms. Dobson discussed
89 the warranty for the rubber surface material. Ms. Dobson stated that she could send the warranty
90 language over to District Counsel for review and touch base with the vendor.

91 The Board and Ms. Dobson also discussed scheduling an in-person ethics training session to fulfill
92 the annual requirement for Supervisors, with a tentative date and time being set for October 21
93 from 10:00 a.m. to 2:00 p.m.

94 A resident request was relayed to extend lap pool heating to a longer portion of the calendar year.
95 Ms. Dobson clarified that the standing policy was to regularly run the pool heater until the ambient
96 temperature allowed the pool water to maintain itself above 65 degrees at night, and then resume
97 regular pool heating with the first cold snap which was typically around October. The Board
98 suggested that pool temperatures be monitored throughout the year so that the specific temperature
99 data could be collected, and Ms. Dobson stated that she could discuss with Cooper Pools on getting
100 a commercial-grade thermostat system for accurate readings. Additional discussion ensued
101 regarding a new pickleball system and specifications included.

102 1. Form 1 Submittal Reminder: July 1st

103 E. Landscaping & Irrigation

104 1. Exhibit 5: RedTree Report – April 2026 & May 2026

105 2. Exhibit 6: RedTree Landscape Inspection Report – May 2026

106 Mr. Lucadano presented the reports to the Board, discussing the removal of weeds and
107 dead plant material, as well as the mowing schedule. Ms. Dobson commented positively
108 on crews’ flexibility in tweaking schedules to address the removals, though noted that there
109 had been some areas with possible overspraying for weed control. Additional discussion
110 occurred regarding an uptick in rainfall patterns.

111 Ms. Hepner recalled some vine ground cover by a monument that had died and been
112 removed, and asked whether there were currently any plans to install other plant material
113 in the area. Ms. Dobson noted that different plant materials had been installed at different
114 monuments with varying survival success particularly during the January and February
115 freezes. Comments were made noting the hardiness of the larger natal palms.

116 3. RedTree Proposals (if any)

117 **SEVENTH ORDER OF BUSINESS – Consent Agenda**

118 A. Exhibit 7: Consideration for Approval – The Minutes of the Board of Supervisors Regular Meeting
119 Held on May 7, 2026

120 B. Exhibit 8: Consideration for Acceptance – The April 2026 Unaudited Financial Statements

121 C. Exhibit 9: Consideration for Acceptance – The April 2026 Operations & Maintenance Expenditures

122 On a MOTION by Ms. Hepner, SECONDED by Ms. Edwards, WITH ALL IN FAVOR, the Board
123 approved items A-C of the Consent Agenda, as presented, for the Preserve at Wilderness Lake Community
124 Development District.

125 D. Exhibit 10: Ratification of RedTree Proposals

126 1. Revised – Tree Removal & Replacement - \$2,025.00

- 127 2. Revised – Palm Replacement - \$675.00
- 128 3. Revised – Tree Replacement - \$1,725.00
- 129 4. Revised – Sod & Viburnum Odoratissimum Installation - \$4,500.00
- 130 5. Viburnum Odoratissimum Installation - \$390.00
- 131 6. Viburnum Odoratissimum Installation - \$500.00
- 132 7. Foxtail Palm Installation - \$545.00

133 Positive comments were made on the appearance of the newly installed foxtail palm.

134 On a MOTION by Ms. Edwards, SECONDED by Ms. Hepner, WITH ALL IN FAVOR, the Board
135 approved the ratification of all RedTree proposals, as presented, for the Preserve at Wilderness Lake
136 Community Development District.

- 137 E. Exhibit 11: Ratification of Site Masters Pavilion Demolition Proposal - \$1,600.00

138 On a MOTION by Ms. Hepner, SECONDED by Ms. Edwards, WITH ALL IN FAVOR, the Board
139 approved the ratification of the Site Masters Pavilion Demolition Proposal, for the Preserve at Wilderness
140 Lake Community Development District.

141 **EIGHTH ORDER OF BUSINESS – Business Items**

- 142 A. Exhibit 12: Presentation & Acceptance of the Final FY 2025 Audited Financial Report

143 On a MOTION by Ms. Hepner, SECONDED by Ms. Ruhlig, WITH ALL IN FAVOR, the Board accepted
144 the Final FY 2025 Audited Financial Report, for the Preserve at Wilderness Lake Community Development
145 District.

146 **NINTH ORDER OF BUSINESS – Supervisors’ Requests**

147 The Board and Ms. Dobson discussed the circumstances of the recent passing of Fiona, a bearded
148 dragon at the Lodge. Ms. Dobson noted that Fiona had been 8 years old, and the typical lifespan of
149 bearded dragons was anywhere from 8 to 15 years, and that the vet that she had been taken to had
150 assured the team that she had been treated well. Ms. Dobson noted that the team was looking into
151 different flooring surfaces for the cage prior to bringing in anyone new for the Lodge, as there were
152 small crevices in the current surface that made it a more involved process to properly clean and
153 sanitize.

154 **TENTH ORDER OF BUSINESS – Audience Comments – New Business – (limited to 3 minutes per
155 individual for non-agenda items)**

156 There being none, the next item followed.

157 **ELEVENTH ORDER OF BUSINESS – Next Meeting Quorum Check: July 1 at 9:30 AM**

158 Ms. Edwards, Mr. Staples, Ms. Ruhlig, and Ms. Hepner stated that they would be able to attend the
159 next meeting in person, which would constitute a quorum. Ms. Fisher stated that she could attend
160 the meeting via phone.

161 **TWELFTH ORDER OF BUSINESS – Adjournment**

162 Ms. Dobson asked for final questions, comments, or corrections from the Board. There being none,
163 Ms. Ruhlig made a motion to adjourn the meeting.

164 On a MOTION by Ms. Ruhlig, SECONDED by Ms. Hepner, WITH ALL IN FAVOR, the Board adjourned
 165 the meeting at 8:52 p.m., for the Preserve at Wilderness Lake Community Development District.

166 **Each person who decides to appeal any decision made by the Board with respect to any matter considered*
 167 *at the meeting is advised that person may need to ensure that a verbatim record of the proceedings is made,*
 168 *including the testimony and evidence upon which such appeal is to be based.*

169 **Meeting minutes were approved at a meeting by vote of the Board of Supervisors at a publicly noticed**
 170 **meeting held on July 1, 2026.**

171

172

173

Signature

Signature

Printed Name

Printed Name

174 **Title:** **Secretary** **Assistant Secretary**

Title: **Chairman** **Vice Chairman**

EXHIBIT 8

The Preserve at Wilderness Lake Community Development District

Financial Statements
(Unaudited)

Preliminary

May 31, 2026

The Preserve at Wilderness Lake CDD
Balance Sheet
May 31, 2026

	<u>General Fund</u>	<u>Reserve Fund</u>	<u>Debt Service 2012</u>	<u>Debt Service 2013</u>	<u>TOTAL</u>
1 <u>ASSETS</u>					
2 BankUnited Operating	\$ 63,630	\$ -	\$ -	\$ -	\$ 63,630
3 BankUnited Money Market	2,253,036	-	-	-	2,253,036
4 Truist Operating	114,046	-	-	-	114,046
5 Petty Cash	300	-	-	-	300
6 Trust Accounts:					
7 Revenue Fund	-	-	27,599	46,450	74,049
8 Reserve Fund	-	-	128,912	147,867	276,779
9 Interest Fund	-	-	-	-	-
10 Prepayment Fund	-	-	1,941	6,266	8,207
11 Accounts Receivable	-	-	-	-	-
12 Assessments Receivable - On Roll	-	-	-	-	-
13 Due From Other Funds	-	1,176,508	5,021	9,777	1,191,305
14 Prepaid Expenses	2,128	-	-	-	2,128
15 Deposits	28,750	-	-	-	28,750
16 Undeposited Funds	-	-	-	-	-
17 Due From Other Gov'tl Units	-	-	-	-	-
18 <u>TOTAL ASSETS</u>	<u>\$ 2,461,890</u>	<u>\$ 1,176,508</u>	<u>\$ 163,472</u>	<u>\$ 210,360</u>	<u>\$ 4,012,230</u>
19 <u>LIABILITIES</u>					
20 Accounts Payable	\$ 59,193	\$ -	\$ -	\$ -	\$ 59,193
21 Rental Deposits Payable	-	-	-	-	-
22 Sales Tax Payable	-	-	-	-	-
23 Deferred Revenue - On-Roll	-	-	-	-	-
24 Due To Other Funds	1,191,305	-	-	-	1,191,305
25 Due To Other Districts	-	-	-	-	-
26 Outstanding Checks	-	-	-	-	-
27 <u>TOTAL LIABILITIES</u>	<u>1,250,498</u>	<u>-</u>	<u>-</u>	<u>-</u>	<u>1,250,498</u>
28 <u>FUND BALANCE</u>					
29 Nonspendable					
30 Prepaid & Deposits	30,878	-	-	-	30,878
32 Capital Reserves	-	-	-	-	-
31 Operating Capital	338,587	-	-	-	338,587
33 Unassigned	841,927	1,176,508	163,472	210,360	2,392,267
34 <u>TOTAL FUND BALANCE</u>	<u>1,211,392</u>	<u>1,176,508</u>	<u>163,472</u>	<u>210,360</u>	<u>2,761,732</u>
35 <u>TOTAL LIABILITIES & FUND BALANCE</u>	<u>\$ 2,461,890</u>	<u>\$ 1,176,508</u>	<u>\$ 163,472</u>	<u>\$ 210,360</u>	<u>\$ 4,012,230</u>

The Preserve at Wilderness Lake CDD
General Fund
Statement of Revenue, Expenditures, and Changes in Fund Balance
For the period from October 1, 2025 to May 31, 2026

	FY 2026 Adopted Budget	FY 2026 Year-to-Date Budget	FY 2026 Month of May	FY 2026 Year-to-Date Actual	VARIANCE Over (Under) FY Budget	% Actual YTD / FY Budget
1 REVENUES						
2 SPECIAL ASSESSMENTS						
3 Assessments On-Roll	\$ 1,783,447	\$ 1,188,965	\$ 3,256	\$ 1,802,772	\$ 19,325	101%
4 OTHER REVENUES						
5 Interest Income - Operating	10,500	7,000	14	335	(10,165)	3%
6 Interest Income - Money Market	-	-	6,203	45,179	45,179	
7 Rental Revenue	15,000	10,000	1,716	8,931	(6,069)	60%
8 General Store	12,000	8,000	678	6,251	(5,749)	52%
9 Events	7,500	5,000	778	4,546	(2,954)	61%
10 Guest Fees & Access Cards	5,000	3,333	568	6,202	1,202	124%
11 TOTAL REVENUES	1,833,447	1,222,298	13,214	1,874,215	40,768	102%
12 Balance Forward from Previous Year	198,075	132,050	-	-	(198,075)	
13 TOTAL REVENUES & BALANCE FORWARD	\$ 2,031,522	\$ 1,354,348	\$ 13,214	\$ 1,874,215	\$ (157,307)	92%
14 EXPENDITURES						
15 FINANCIAL & ADMINISTRATIVE						
16 Supervisor Fees	\$ 14,000	\$ 9,333	\$ 1,000	\$ 9,000	\$ (5,000)	64%
17 Administrative Services	9,146	6,097	762	6,097	(3,049)	67%
18 District Management	38,180	25,453	3,182	25,453	(12,727)	67%
19 District Engineer	30,000	20,000	1,680	8,160	(21,840)	27%
20 Disclosure Report	2,200	1,467	-	2,200	-	100%
21 Trustees Fees	7,000	4,667	-	6,923	(77)	99%
22 Tax Collector /Property Appraiser Fees	315	210	-	-	(315)	0%
23 Financial & Revenue Collections	5,896	3,931	491	3,931	(1,965)	67%
24 Assessment Roll	5,896	3,931	491	3,931	(1,965)	67%
25 Accounting Services	26,784	17,856	2,232	17,856	(8,928)	67%
26 Auditing Services	4,000	2,667	-	-	(4,000)	0%
27 Legal Advertising	2,700	1,800	-	1,004	(1,696)	37%
28 Misc. Mailings (Mailed Notices)	2,500	1,667	15	56	(2,444)	2%
29 Dues, Licenses & Fees	1,000	667	-	325	(675)	33%
30 Website Fees & Maintenance	4,000	2,667	-	1,561	(2,439)	39%
31 Bank Fees	1,000	667	-	-	(1,000)	0%
32 District Counsel	20,000	13,333	811	14,750	(5,250)	74%
33 TOTAL FINANCIAL & ADMINISTRATIVE	174,617	116,411	10,664	101,247	(73,370)	58%

	FY 2026 Adopted Budget	FY 2026 Year-to-Date Budget	FY 2026 Month of May	FY 2026 Year-to-Date Actual	VARIANCE Over (Under) FY Budget	% Actual YTD / FY Budget
34 INSURANCE						
35 Public Officials Liability Insurance	3,405	2,270	-	-	(3,405)	0%
36 Supervisor Workers Compensation Insurance	850	567	-	850	-	100%
37 Property & General Liability Insurance	65,000	43,333	-	63,388	(1,612)	98%
38 TOTAL INSURANCE	69,255	46,170	-	64,238	(5,017)	93%
39 LAW ENFORCEMENT						
40 Off-Duty Deputy	25,000	16,667	-	14,810	(10,190)	59%
41 TOTAL LAW ENFORCEMENT	25,000	16,667	-	14,810	(10,190)	59%
42 UTILITIES						
43 Electric Utility Services	185,000	123,333	14,429	107,158	(77,842)	58%
44 Gas Utility Services	30,000	20,000	679	24,868	(5,132)	83%
45 Garbage - Recreation Facility	7,000	4,667	1,052	6,491	(509)	93%
46 Solid Waste Assessment	5,000	3,333	-	8,333	3,333	167%
47 Water - Sewer Utility Services	27,000	18,000	2,557	12,738	(14,262)	47%
48 Stormwater Control Assessment	4,000	2,667	-	-	(4,000)	0%
49 TOTAL UTILITIES	258,000	172,000	18,716	159,589	(98,411)	62%
50 LANDSCAPE						
51 Landscape Maintenance	162,540	108,360	12,900	103,200	(59,340)	63%
52 Landscape Fertilization	30,000	20,000	-	-	(30,000)	0%
53 Annual Flower Rotation	33,000	22,000	-	24,750	(8,250)	75%
54 Landscape Replacement Plants, Shrubs, Trees	40,000	26,667	2,913	4,008	(35,992)	10%
55 Landscape - Mulch	45,000	30,000	-	-	(45,000)	0%
56 Landscape Inspections (PSA)	14,400	9,600	1,100	8,800	(5,600)	61%
57 Landscape Pest Control	13,980	9,320	-	-	(13,980)	0%
58 Landscape Aeration	4,000	2,667	-	-	(4,000)	0%
59 Tree Trimming and Removal Services	75,000	50,000	2,900	55,655	(19,345)	74%
60 Palm Tree Trimming	15,000	10,000	-	18,000	3,000	120%
61 Hardwood Tree Pruning	12,600	8,400	1,000	8,000	(4,600)	63%
62 Irrigation Maint. & Repairs	25,000	16,667	1,599	11,730	(13,270)	47%
63 Irrigation Inspection	13,860	9,240	-	7,700	(6,160)	56%
64 Well Maintenance	2,500	1,667	-	-	(2,500)	0%
65 TOTAL LANDSCAPE	486,880	324,587	22,412	241,842	(245,038)	50%
66 LAKE AND WETLAND MAINTENANCE						
67 Monthly Aquatic Weed Control Program	34,500	23,000	2,875	17,250	(17,250)	50%
68 Staff Oversight & Buffer Herbicide	2,000	1,333	167	1,000	(1,000)	50%
69 Private Resident Consultation	780	520	65	390	(390)	50%

	FY 2026 Adopted Budget	FY 2026 Year-to-Date Budget	FY 2026 Month of May	FY 2026 Year-to-Date Actual	VARIANCE Over (Under) FY Budget	% Actual YTD / FY Budget
70 Wetland Nuisance/Exotic Species Control	10,500	7,000	875	5,250	(5,250)	50%
71 Woodline Routine clean up	26,400	17,600	2,200	10,472	(15,928)	40%
72 Misc. Expense	15,000	10,000	-	-	(15,000)	0%
73 TOTAL LAKE AND WETLAND MAINTENANCE	89,180	59,453	6,182	34,362	(54,818)	39%
74 ROAD & STREET FACILITIES						
75 Street Sign Repair & Maintenance	1,000	667	-	-	(1,000)	0%
76 Sidewalk Repair & Maintenance	7,000	4,667	-	-	(7,000)	0%
77 Sidewalk Pressure Washing	9,000	6,000	-	4,488	(4,512)	50%
78 Entry & Walls Maintenance	2,000	1,333	-	363	(1,637)	18%
79 TOTAL ROAD & STREET FACILITIES	19,000	12,667	-	4,851	(14,149)	26%
80 PARKS & RECREATION						
81 Contract - Management Fee	55,620	37,080	4,635	37,080	(18,540)	67%
83 Contract - Employee Salaries	490,300	326,867	37,901	289,083	(201,217)	59%
82 Payroll Reimbursement - Mileage	2,500	1,667	-	-	(2,500)	0%
84 Lodge Repair & Maintenance	55,000	36,667	1,460	24,901	(30,099)	45%
85 Lodge Janitorial Services	28,000	18,667	2,100	16,800	(11,200)	60%
86 Lodge Janitorial Supplies	8,000	5,333	444	5,191	(2,809)	65%
87 Spa Linen & Mat Services	3,000	2,000	-	-	(3,000)	0%
88 Pool Service Contract	58,520	39,013	6,439	37,299	(21,222)	64%
89 Pool Repair & Maintenance	8,500	5,667	584	8,683	183	102%
90 Pool Permits	1,000	667	850	850	(150)	85%
91 Telephone Fax, Internet	14,000	9,333	1,052	8,305	(5,695)	59%
92 IT Support and Repairs	3,750	2,500	-	112	(3,638)	3%
93 Security System Monitoring	8,000	5,333	223	2,383	(5,617)	30%
94 Security System Maintenance	9,000	6,000	600	4,200	(4,800)	47%
95 Resident Services	8,000	5,333	202	4,005	(3,995)	50%
96 Resident ID Card	1,500	1,000	-	1,050	(450)	70%
97 Office Supplies	7,000	4,667	4,473	8,686	1,686	124%
98 General Store	6,000	4,000	4,266	6,565	565	109%
99 Nature Center Operations	7,500	5,000	107	2,563	(4,937)	34%
100 Wildlife Management Services	14,400	9,600	1,200	9,780	(4,620)	68%
101 Special Events	35,000	23,333	769	22,957	(12,043)	66%
102 Fitness Equipment Preventative Maintenance	1,500	1,000	125	1,000	(500)	67%
103 Fitness Equipment Repairs	6,000	4,000	351	3,898	(2,102)	65%
104 Lift and Equipment Rentals	4,000	2,667	-	2,268	(1,732)	57%
105 Furniture and Equipment Repair/Replacement	15,000	10,000	-	4,023	(10,977)	27%
106 Athletic/Park Court/Field Repairs/Maint.	7,000	4,667	376	726	(6,274)	10%

	FY 2026 Adopted Budget	FY 2026 Year-to-Date Budget	FY 2026 Month of May	FY 2026 Year-to-Date Actual	VARIANCE Over (Under) FY Budget	% Actual YTD / FY Budget
107 Playground Equipment and Maintenance	3,000	2,000	-	96	(2,904)	3%
108 Playground Mulch	8,500	5,667	7,225	7,225	(1,275)	85%
109 Dog Waste Station Supplies	7,500	5,000	-	3,509	(3,991)	47%
110 Holiday Decorations	16,000	10,667	-	12,353	(3,647)	77%
111 Landscape Lighting Replacement	1,500	1,000	-	1,099	(401)	73%
112 Special Projects	15,000	10,000	-	-	(15,000)	0%
113 TOTAL PARKS AND RECREATION	909,590	606,393	75,381	526,690	(382,900)	58%
114 TOTAL EXPENDITURES	2,031,522	1,354,348	133,355	1,147,630	(883,892)	56%
115 REVENUES OVER (UNDER) EXPENDITURES	-	-	(120,141)	726,586	726,586	
116 OTHER FINANCING SOURCES & USES						
117 Transfers In	-	-	-	-	-	
118 Transfers Out	-	-	-	-	-	
119 TOTAL OTHER FINANCING SOURCES & USES	-	-	-	-	-	
120 NET CHANGE IN FUND BALANCE	-	-	(120,141)	726,586	726,586	
121 Fund Balance - Beginning	323,034			484,806	161,772	
122 Fund Balance Forward	(198,075)					
123 FUND BALANCE - ENDING - PROJECTED	\$ 124,959			\$ 1,211,392	\$ 888,358	

The Preserve at Wilderness Lake CDD
Capital Reserve Fund (CRF)
Statement of Revenue, Expenditures, and Changes in Fund Balance
For the period from October 1, 2025 to May 31, 2026

	FY 2026 Amended Budget	FY 2026 Total Actual Year-to-Date	VARIANCE Over (Under) to Budget
1 REVENUES			
2 Special Assessments - On Roll (Net)	\$ 300,000	\$ 303,155	\$ 3,155
3 Miscellaneous Revenue	-	-	-
4 TOTAL REVENUES	300,000	303,155	3,155
5 EXPENDITURES			
6 Renewal and Replacement	-	-	-
7 Capital Reserves	-	149,873	149,873
8 TOTAL EXPENDITURES	-	149,873	149,873
9 REVENUES OVER (UNDER) EXPENDITURES	300,000	153,282	(146,718)
10 OTHER FINANCING SOURCES & USES			
11 Transfers In	-	-	-
12 Transfers Out	-	-	-
13 TOTAL OTHER FINANCING SOURCES & USES	-	-	-
14 NET CHANGE IN FUND BALANCE	300,000	153,282	(146,718)
15 Fund Balance - Beginning	995,543	1,023,226	27,684
16 FUND BALANCE - ENDING - PROJECTED	\$ 1,295,543	\$ 1,176,508	\$ (119,035)

The Preserve at Wilderness Lake CDD
Debt Service Fund - Series 2012
Statement of Revenue, Expenditures, and Changes in Fund Balance
For the period from October 1, 2025 to May 31, 2026

	FY 2026 Adopted Budget	FY 2026 Total Actual Year-to-Date	VARIANCE Over (Under) to Budget
1 REVENUES			
2 Special Assessments - On Roll (Net)	\$ 154,031	\$ 155,681	\$ 1,650
3 Interest Revenue	-	3,559	3,559
4 Miscellaneous Revenue	-	-	-
5 TOTAL REVENUES	154,031	159,240	5,208
6 EXPENDITURES			
7 Interest Expense			
8 * November 1, 2025	26,472	26,469	3
9 May 1, 2026	26,472	26,066	406
10 November 1, 2026	23,784	-	23,784
11 Principal Retirement			
12 May 1, 2026	100,000	100,000	-
13 Principal Prepayment	-	10,000	(10,000)
14 TOTAL EXPENDITURES	150,256	162,534	12,278
15 REVENUES OVER (UNDER) EXPENDITURES	3,775	(3,295)	(7,070)
16 OTHER FINANCING SOURCES & USES			
17 Transfers In	-	-	-
18 Transfers Out	-	-	-
19 TOTAL OTHER FINANCING SOURCES & USES	-	-	-
20 NET CHANGE IN FUND BALANCE	3,775	(3,295)	(7,070)
21 Fund Balance - Beginning		166,767	166,767
22 FUND BALANCE - ENDING - PROJECTED	\$ 3,775	\$ 163,472	\$ 159,697

* financed by prior year revenues

The Preserve at Wilderness Lake CDD
Debt Service Fund - Series 2013
Statement of Revenue, Expenditures, and Changes in Fund Balance
For the period from October 1, 2025 to May 31, 2026

	FY 2026 Adopted Budget	FY 2026 Total Actual Year-to-Date	VARIANCE Over (Under) to Budget
1 REVENUES			
2 Special Assessments - On Roll (Net)	\$ 299,963	\$ 303,155	\$ 3,192
3 Interest Revenue	-	4,540	4,540
4 Miscellaneous Revenue	-	-	-
5 TOTAL REVENUES	299,963	307,695	7,733
6 EXPENDITURES			
7 Interest Expense			
8 * November 1, 2025	46,589	46,746	(157)
9 May 1, 2026	46,589	46,169	420
10 November 1, 2026	42,231	-	42,231
11 Principal Retirement			
12 May 1, 2026	210,000	205,000	5,000
13 Principal Prepayment	-	20,000	(20,000)
14 TOTAL EXPENDITURES	298,820	317,914	19,094
15 REVENUES OVER (UNDER) EXPENDITURES	1,143	(10,219)	(11,362)
16 OTHER FINANCING SOURCES & USES			
17 Transfers In	-	-	-
18 Transfers Out	-	-	-
19 TOTAL OTHER FINANCING SOURCES & USES	-	-	-
20 NET CHANGE IN FUND BALANCE	1,143	(10,219)	(11,362)
21 Fund Balance - Beginning		220,579	220,579
22 FUND BALANCE - ENDING - PROJECTED	\$ 1,143	\$ 210,360	\$ 209,217

* financed by prior year revenues

The Preserve at Wilderness Lake CDD

Reserve Fund Expenditures FY26

Date	Ref. Num	Name	Memo	Amount
11/01/2025	20255	FlamePro Inc.	Reference: LODGE: Replaced existing 24" vent free gas log set and burner with new RH Peterson 24...	2,786.00
11/01/2025	20254	FlamePro Inc.	Reference: OUTDOOR:: Replaced existing 24" log set and burner with new RH Peterson 24" stainless...	3,556.00
11/01/2025	20256	FlamePro Inc.	Reference: Activities Room: Replaced existing 24" vent free gas log set and burner with new RH P...	2,786.00
12/10/2025	100998	Walt's Upholstery, Inc.	Invoice: 8315 (Reference: Deposit.)	7,070.00
12/11/2025	101000	Finn Outdoor LLC	Invoice: 2972 (Reference: Pond Maintenance.) Invoice: 2973 (Reference: Control Structure & Dr...	43,300.00
12/11/2025	101004	Superior Sealers LLC	Invoice: INV-109 (Reference: 50% Parking Lot Cleaning Deposit.)	6,017.50
12/15/2025	32412	RedTree Landscape Systems	Reference: Irrigation repair.	9,612.20
01/07/2026	010726-2	Site Masters Of Florida LLC	Pond 20 Dredging	4,250.00
01/16/2026	011626-1	Site Masters Of Florida LLC	Pond 20 Dredging - Final	4,250.00
01/29/2026	012926-3	Site Masters Of Florida LLC	Replace deteriorated grate on outfall structure BB-C1	3,500.00
02/03/2026	020326-1	Site Masters Of Florida LLC	Repair pond erosion Draycott Way	1,200.00
02/17/2026	021726-2	Site Masters Of Florida LLC	Sediment removal Pond 1	3,200.00
02/17/2026	021726-1	Site Masters Of Florida LLC	Vegetation Overgrowth removal Pond 1	2,800.00
02/24/2026	44578702	McNatt Plumbing Company LLC	Reference: Proposal Work - Fitness Center.	2,077.00
03/05/2026	547	Cooper Pools Inc.	Reference: Commercial Installation / Repairs.	1,241.20
03/09/2026	167	Brian Peters LLC	Reference: Down payment for fascia trim and gutter replacements.	6,000.00
03/10/2026	558	Cooper Pools Inc.	Reference: Removal and Installation of motor for ADA chair.	1,195.27
03/12/2026	33475	RedTree Landscape Systems	Center Median at U.S 41 and Wilderness Lake Blvd..	4,800.00
03/12/2026	33474	RedTree Landscape Systems	Basketball Court Landscape Enhancement.	4,875.00
03/15/2026	INV-125	Superior Sealers LLC	Final Payment.	6,017.50
03/19/2026	592	Cooper Pools Inc.	Spa ADA Chair Repair Quote.	1,000.00
03/22/2026	SOTAM6899	Leaders Casual Furniture	Replacement of poolside chairs	2,255.00
04/08/2026	1209		Miller-Pond slope damage- Site Masters Inv 020326-1	(1,200.00)
04/08/2026	23056	Romaner Graphics	remove enough soil to lower 5x5 gate post so that gate can be level. Align gate to be level with...	1,150.00
04/15/2026	23073	Romaner Graphics	Repair Vinyl Gate.	350.00
04/29/2026	QTAM5386	Leaders Casual Furniture	Poolside replacement umbrellas	796.97
05/01/2026	731	Cooper Pools Inc.	Splash Pad Motor Replacement. Check spa feature breaker- tech reports it is loud..	1,094.39
05/07/2026	38644	FitRev Inc	2 Treadmills.	14,495.40
05/15/2026	761	Cooper Pools Inc.	Install Light at Resort Pool.	1,536.32
05/15/2026	760	Cooper Pools Inc.	Remove & Install 5 White Pool Lights.	7,861.60
5/31/2026				149,873.35

The Preserve at Wilderness Lake CDD

Special Projects Expenditures FY26

Date	Ref. Num	Name	Memo	Amount
05/31/2026	Total Special Projects Expenditures			-

The Preserve at Wilderness Lake CDD
Check Register - BankUnited Operating - FY2026

Date	Number	Name	Memo	Deposits	Payments	Balance
09/30/2025		Beginning of Year				203,424.18
10/01/2025	100917	RedTree Landscape Systems	Invoice: 31608 (Reference: irrigation repairs.)		797.50	202,626.68
10/01/2025	100918	Cooper Pools Inc.	Invoice: 2025-1215 (Reference: COMMERCIAL SERVICE CALL / INSTALLATION.)		1,526.50	201,100.18
10/02/2025	01ACH100225	Frontier	Business Fiber Internet - 21320 Wilderness Lake Blvd.09.07.25- 10.06.25		468.38	200,631.80
10/03/2025	100919	Vesta Property Services, Inc	Invoice: 428861 (Reference: Management fees.)		41,428.72	159,203.08
10/03/2025	100920	Strictly Entertainment, Inc.	Invoice: 30789 (Reference: Entertainment 12/6 & 12/20.)		2,360.00	156,843.08
10/03/2025	100921	A Total Solution, Inc	Invoice: 000201745 (Reference: Quarterly service charge for monitoring Security Video Alarm Syst...		1,391.16	155,451.92
10/03/2025	100922	Pasco Sheriff's Office	Invoice: I-20259-12106 (Reference: Security.)		2,360.00	153,091.92
10/03/2025	100923	Cooper Pools Inc.	Invoice: 2025-1294 (Reference: Monthly Commercial Maintenance October 2025.)		4,362.00	148,729.92
10/03/2025	100924	Fitness Logic	Invoice: 126461 ()		216.99	148,512.93
10/03/2025	100925	McNatt's Cleaners	Invoice: 100125-2927 (Reference: laundry.)		38.00	148,474.93
10/06/2025	01ACH100625	Duke Energy	Summary Bill account 08.05.25- 09.03.25		1,630.93	146,844.00
10/06/2025	02ACH100625	BANK UNITED VISA CC	office items		3,852.80	142,991.20
10/08/2025	1362	Heather Hepner	BOS Meeting 3/5/25		200.00	142,791.20
10/08/2025	1363	Agnieszka Fisher	Ethics Workshop 10/7/25		200.00	142,591.20
10/08/2025	1364	Heather Hepner	Ethics Workshop 10/7/25		200.00	142,391.20
10/08/2025	1365	Holly Ruhlig	Ethics Workshop 10/7/25		200.00	142,191.20
10/08/2025	1366	John Staples	Ethics Workshop 10/7/25		200.00	141,991.20
10/08/2025	1367	Virginia B. Edwards	Ethics Workshop 10/7/25		200.00	141,791.20
10/08/2025	1368	Agnieszka Fisher	BOS Meeting 10/1/25		200.00	141,591.20
10/08/2025	1369	Heather Hepner	BOS Meeting 10/1/25		200.00	141,391.20
10/08/2025	1370	Holly Ruhlig	BOS Meeting 10/1/25		200.00	141,191.20
10/08/2025	1371	John Staples	BOS Meeting 10/1/25		200.00	140,991.20
10/08/2025	1372	Virginia B. Edwards	BOS Meeting 10/1/25		200.00	140,791.20
10/08/2025	1373	Egis Insurance & Risk Advisors	Policy #100125678 10/01/25 - 10/01/26		63,388.00	77,403.20
10/10/2025	01ACH101025	Frontier	FiberOptic Internet 200 static IP- 20750 Wilderness Lake Blvd. 09.15.25- 10.14.25		115.98	77,287.22
10/15/2025	100926	Straley Robin Vericker	Invoice: 27296 (Reference: For Professional Services Rendered Through September 30, 2025.)		2,297.60	74,989.62
10/17/2025	1374	Egis Insurance & Risk Advisors	Policy # WC100135678 10/01/25-10/01/26		850.00	74,139.62
10/17/2025	100927	RedTree Landscape Systems	Invoice: 31640 (Reference: ground Maintenance and irrigation inspection.) Invoice: 31877 (Ref...		23,385.25	50,754.37
10/17/2025	100928	State Wildlife Trapper, LLC	Invoice: 2075 (Reference: State Wildlife Service Service for October 2025.)		1,200.00	49,554.37
10/17/2025	100929	Nelson's CPR & First Aid Training, LLC	Invoice: 3871 (Reference: AED Cabinet Base-OBC with alarm & 3D.)		1,728.00	47,826.37
10/17/2025	100930	PSA Horticultural	Invoice: 1625 (Reference: October 2025 Landscape Inspection.)		1,100.00	46,726.37
10/17/2025	100931	Arrow Exterminators	Invoice: 64168457 (Reference: Commercial Pest Service.)		158.00	46,568.37
10/17/2025	100932	Cooper Pools Inc.	Invoice: 2025-1305 (Reference: service call pool repair.)		225.00	46,343.37
10/17/2025	100933	A Total Solution, Inc	Invoice: i4248 (Reference: Inspection Quarterly F/S.)		35.00	46,308.37
10/17/2025	100934	Brietic Dvorak Inc	Invoice: 2146 (Reference: project manager.)		210.00	46,098.37
10/17/2025	100935	Vesta District Services	Invoice: 428942 (Reference: Management fees.) Invoice: 428985 (Reference: FY?2026 Dissminatio...		9,480.44	36,617.93
10/17/2025	100936	Uline, Inc.	Invoice: 198116545 (Reference: Brown Carpet mat.)		88.18	36,529.75
10/17/2025	01ACH101725	Frontier	Local service 7218 Night Heron Dr 08.21.25- 09.21.25		145.49	36,384.26
10/20/2025			Funds Transfer	100,000.00		136,384.26
10/20/2025	100937	Palm Beach Security & Safe, Inc.	Invoice: 12763 (Reference: lodge repair.)		538.00	135,846.26
10/20/2025	EFT102025	FL Dept. of Rev.	September 2025 Sales Tax		191.15	135,655.11
10/22/2025	01ACH102225	Pasco County Utilities	0 Whispering Wind Dr. 8.14.25- 9.15.25		194.71	135,460.40
10/22/2025	02ACH102225	Pasco County Utilities	0 Waverly Shores Lane 8.14.25- 9.12.25		10.60	135,449.80
10/22/2025	03ACH102225	Pasco County Utilities	7639 Grasmere Dr 8.14.25- 9.12.25		10.60	135,439.20
10/22/2025	04ACH102225	Pasco County Utilities	21922 Waverly Shores Lane 8.14.25- 9.12.25		10.60	135,428.60
10/22/2025	05ACH102225	Pasco County Utilities	21539 Cormorant Cove Dr 8.14.25- 9.12.25		10.60	135,418.00
10/22/2025	06ACH102225	Pasco County Utilities	20750 Wilderness Lake Blvd 8.14.25- 9.15.25		33.17	135,384.83
10/22/2025	07ACH102225	Pasco County Utilities	21320 Wilderness Lake Blvd 8.14.25- 9.15.25		1,400.85	133,983.98
10/23/2025	01ACH102325	Waste Connections Of Florida	Monthly Fee - 11.01.25- 11.30.25		715.33	133,268.65
10/24/2025	100938	RedTree Landscape Systems	Invoice: 31951 (Reference: irrigation repairs.)		144.07	133,124.58
10/24/2025	100939	Inteligy Tampa Bay LLC	Invoice: 23529 (Reference: flat rare hosted services and T-38 faxing services.)		330.00	132,794.58
10/24/2025	100940	Electro Sanitation Services	Invoice: INV-000142 (Reference: Janitorial supplies.) Invoice: INV-000141 (Reference: Weekly ...		2,546.75	130,247.83
10/24/2025	100941	Arrow Exterminators	Invoice: 64398948 (Reference: pest control service.)		350.00	129,897.83
10/24/2025	100942	Fitness Logic	Invoice: 126763 (Reference: Monthly General Maintenance and cleaning of all equipment.)		125.00	129,772.83
10/24/2025	100943	GHS, LLC	Invoice: 2025-634 (Reference: Monthly aquatic weed control program.)		3,981.67	125,791.16
10/24/2025	100944	Ready Refresh	Invoice: 25J0006240923 (Reference: water services.)		168.88	125,622.28
10/24/2025	100945	Head's Flags Inc.	Invoice: 24805 (Reference: 8x12 US Nylon Flag.)		221.19	125,401.09
10/24/2025	100946	SchoolNow	Invoice: INV-SN-1069 (Reference: Website Hosting.)		1,537.50	123,863.59
10/27/2025	1375	Inteligy Tampa Bay LLC	Reference: flat rate hosted services and T-38 faxing services.		480.00	123,383.59

Date	Number	Name	Memo	Deposits	Payments	Balance
10/28/2025	1376	Ellen L Dobson - Petty Cash	Reimbursements		286.59	123,097.00
10/28/2025	100947	Sunrise Propane	Invoice: U111K250 (Reference: Propane 723.3 gal.)		1,851.65	121,245.35
10/28/2025	100948	Peloton Interactive Inc.	Invoice: 23193997 (Reference: subscription (1year x4).)		2,112.00	119,133.35
10/28/2025	100949	RedTree Landscape Systems	Invoice: 31955 (Reference: irrigation repairs.)		610.00	118,523.35
10/29/2025	01ACH102925	Duke Energy	Summary Account 08.27.25- 09.25.25		14,092.43	104,430.92
10/29/2025	02ACH102925	Duke Energy	7973 Citrus Blossom Dr- Herons Glen 09.04.25- 10.02.25		30.80	104,400.12
10/31/2025			Interest	14.08		104,414.20
10/31/2025	End of Month			100,014.08	199,024.06	104,414.20
11/03/2025			Deposit	11,334.00		115,748.20
11/03/2025	100950	Pasco Sheriff's Office	Invoice: I-202510-12246 (Reference: Security.)		2,130.00	113,618.20
11/03/2025	100951	Fitness Logic	Invoice: 126919 (Reference: Replace pedal set and left crank arm on Peloton Spin bike serial # R...		346.98	113,271.22
11/03/2025	100952	GHS, LLC	Invoice: 2025-695 (Reference: Monthly aquatic weed control program.)		3,981.67	109,289.55
11/03/2025	100953	RedTree Landscape Systems	Invoice: 31905 (Reference: Arbor Care Perform palm tree trimming.) Invoice: 31436 (Reference:...		6,750.00	102,539.55
11/03/2025	100954	SmartTech ID Company, Inc.	Invoice: 103025-WL_RIBB (Reference: (2) 200 Single Sided Full Color Cards.)		146.00	102,393.55
11/03/2025	01ACH110325	Frontier	Business Fiber Internet - 21320 Wilderness Lake Blvd.10.07.25-11.06.25		402.84	101,990.71
11/04/2025	01ACH110425	BANK UNITED VISA CC			3,827.91	98,162.80
11/05/2025	01ACH110525	Duke Energy	Summary Bill account 09.04.25- 10.02.25		1,732.24	96,430.56
11/06/2025			Deposit	296.68		96,727.24
11/06/2025			Deposit	44,970.22		141,697.46
11/10/2025	1377	Agnieszka Fisher	BOS Meeting 11/5/25		200.00	141,497.46
11/10/2025	1378	Heather Hepner	BOS Meeting 11/5/25		200.00	141,297.46
11/10/2025	1379	Holly Ruhlig	BOS Meeting 11/5/25		200.00	141,097.46
11/10/2025	1380	John Staples	BOS Meeting 11/5/25		200.00	140,897.46
11/10/2025	1381	Virginia B. Edwards	BOS Meeting 11/5/25		200.00	140,697.46
11/10/2025			Deposit	0.08		140,697.54
11/12/2025	100955	Cooper Pools Inc.	Invoice: 2025-1411 (Reference: Monthly Commercial Maintenance November 2025.) Invoice: 277 (R...		4,520.45	136,177.09
11/12/2025	100956	McNatt's Cleaners	Invoice: 110125-2927 (Reference: Laundry.)		64.60	136,112.49
11/12/2025	100957	FlamePro Inc.	Invoice: 20208 (Reference: lodge repairs.) Invoice: 20210 (Reference: Replaced operating pres...		9,941.50	126,170.99
11/12/2025	100958	Brletic Dvorak Inc	Invoice: 2180 (Reference: Engineering services.)		630.00	125,540.99
11/12/2025	100959	Vesta District Services	Invoice: 429510 (Reference: Management fee services.)		7,158.50	118,382.49
11/12/2025	100960	Sunrise Propane	Invoice: U111K426 (Reference: Propane 863.4 gal.)		2,210.30	116,172.19
11/12/2025	100961	ProPet Distributors	Invoice: 2001626 (Reference: Dog waste station supplies.)		451.55	115,720.64
11/12/2025	100962	RedTree Landscape Systems	Invoice: 32121 (Reference: Palm Tree Trimming.)		6,000.00	109,720.64
11/12/2025	100963	Vesta Property Services, Inc	Invoice: 429352 (Reference: Management fee services.)		42,969.85	66,750.79
11/12/2025	100964	City Electric Supply Company	Invoice: LOL/218036 (Reference: landscape repair.)		276.06	66,474.73
11/12/2025	01ACH111225	Frontier	FiberOptic Internet 200 static IP- 20750 Wilderness Lake Blvd. 10.15.25- 11.14.25		125.98	66,348.75
11/14/2025			Deposit	131,529.53		197,878.28
11/18/2025	01ACH111825	Frontier	Local service 7218 Night Heron Dr 10.22.25- 11.21.25		145.49	197,732.79
11/19/2025	100965	Himes Electrical Service, Inc.	Invoice: 25197 (Reference: Replaced wall pack not working on the back side of the club house..)		516.05	197,216.74
11/19/2025	100966	RedTree Landscape Systems	Invoice: 31996 (Reference: irrigation, arbor care and ground maintenance.) Invoice: 32226 (Re...		15,338.57	181,878.17
11/19/2025	100967	DCSI, Inc.	Invoice: 34415 (Reference: service call: Front PTZ camera is offline..)		145.00	181,733.17
11/19/2025	100968	City Electric Supply Company	Invoice: LOL/218171 (Reference: landscape replacement.)		341.87	181,391.30
11/19/2025	100969	A Total Solution, Inc	Invoice: i6227 (Reference: Annual fire sprinkler and back flow inspections completed. No deficie...		317.92	181,073.38
11/19/2025	100970	PSA Horticultural	Invoice: 1635 (Reference: November 2025 Landscape Inspection.)		1,100.00	179,973.38
11/19/2025	100971	Ierna's Heating, Cooling & Plumbing, Inc.	Invoice: 3125884 (Reference: lodge repairs.) Invoice: 3125892 (Reference: Replace 1/2 copper ...		1,026.00	178,947.38
11/19/2025	100972	Arrow Exterminators	Invoice: 64880015 (Reference: Pest Control Service.)		350.00	178,597.38
11/19/2025	100973	Straley Robin Vericker	Invoice: 27480 (Reference: District Counsel services.)		3,988.50	174,608.88
11/19/2025	ACH111925	FL Dept. of Rev.	October 2025 Sales Tax		300.40	174,308.48
11/20/2025	100974	Extreme Concrete Cleaning	Invoice: 7122 (Reference: Treat sidewalks and curbs every 6 months.)		4,488.00	169,820.48
11/20/2025	100975	Sunrise Propane	Invoice: U111K518 (Reference: 754.0 gal Propane.)		1,930.24	167,890.24
11/20/2025			Deposit	1,954.62		169,844.86
11/20/2025			Deposit	96,538.07		266,382.93
11/21/2025	1382	Mike Fasano, Pasco County Tax Collector	Parcel ID # 35-25-18-0040-00000-L060, 2025 Solid Waste Assessment		109.44	266,273.49
11/21/2025	1383	FLORIDA DEPT OF ECONOMIC OPPORTUNITY	FY 2025/2026 Special District Fee Invoice/Update Form		175.00	266,098.49
11/21/2025	1384	Mike Fasano, Pasco County Tax Collector	Parcel ID # 36-25-18-0010-00000-RC10 2025		2,352.96	263,745.53
11/25/2025	01ACH112525	Waste Connections Of Florida	Monthly Fee - 12.01.25- 12.31.25		712.33	263,033.20
11/26/2025	01ACH112625	Pasco County Utilities	21320 Wilderness Lake Blvd 09.15.25- 10.14.25		691.76	262,341.44
11/26/2025	02ACH112625	Pasco County Utilities	20750 Wilderness Lake Blvd 09.15.25- 10.14.25		34.42	262,307.02
11/26/2025	03ACH112625	Pasco County Utilities	21539 Cormorant Cove Dr 09.12.25- 10.14.25		11.00	262,296.02
11/26/2025	04ACH112625	Pasco County Utilities	7639 Grasmere Dr 09.12.25- 10.14.25		11.00	262,285.02
11/26/2025	05ACH112625	Pasco County Utilities	0 Whispering Wind Dr. 09.15.25- 10.14.2025		11.00	262,274.02
11/26/2025	06ACH112625	Pasco County Utilities	21922 Waverly Shores Lane 09.12.25- 10.14.25		127.20	262,146.82
11/26/2025	07ACH112625	Pasco County Utilities	0 Waverly Shores Lane 09.12.25- 10.14.25		10.86	262,135.96

Date	Number	Name	Memo	Deposits	Payments	Balance
11/26/2025			Deposit	74,355.85		336,491.81
11/28/2025	100976	Cooper Pools Inc.	Invoice: 287 (Reference: VALVE RESERVOIR FLOAT ASSEMBLY.)		137.47	336,354.34
11/28/2025	100977	Ready Refresh	Invoice: 25K0006240923 (Reference: drinking water service.)		225.86	336,128.48
11/28/2025	100978	Frederick Novomestky	Invoice: 125121 (Reference: Florida Jazz Express.)		500.00	335,628.48
11/28/2025	100979	Sunrise Propane	Invoice: U111K607 (Reference: 838.2 gal propane.)		2,145.79	333,482.69
11/28/2025	100980	A Total Solution, Inc	Invoice: i6641 (Reference: lodge repairs.)		440.00	333,042.69
11/28/2025	100981	RedTree Landscape Systems	Invoice: 32243 (Reference: tree removal.) Invoice: 32242 (Reference: tree removal.) Invoic...		19,575.00	313,467.69
11/28/2025	100982	Inteligy Tampa Bay LLC	Invoice: 23666 (Reference: faxing services.)		330.00	313,137.69
11/28/2025	100983	Electro Sanitation Services	Invoice: INV-000153 (Reference: Janitor supplies.) Invoice: INV-000152 (Reference: Weekly Cle...		2,730.57	310,407.12
11/28/2025	100984	Rentalex of Pasco	Invoice: 1-224396 (Reference: SCISSOR LIFT 20' VERTICAL SJ20 SKY.)		702.50	309,704.62
11/30/2025			Interest	19.20		309,723.82
11/30/2025		End of Month		360,998.25	155,688.63	309,723.82
12/01/2025	100985	Himes Electrical Service, Inc.	Invoice: 25004-A (Reference: irrigation and pool repair.)		518.66	309,205.16
12/01/2025	100986	Brietic Dvorak Inc	Invoice: 2097 (Reference: Engineering services.)		725.00	308,480.16
12/02/2025	01ACH120225	Frontier	Business Fiber Internet - 21320 Wilderness Lake Blvd.11.07.25- 12.06.25		428.99	308,051.17
12/03/2025	01ACH120325	Duke Energy	Summary Account 09.26.25- 10.28.25		14,141.05	293,910.12
12/03/2025	02ACH120325	Duke Energy	7973 Citrus Blossom Dr- Herons Glen 10.03.25-11.04.25		30.80	293,879.32
12/04/2025	01ACH120425	BANK UNITED VISA CC	office items		4,783.48	289,095.84
12/04/2025	02ACH120425	Duke Energy	Summary Bill account 10.03.25- 11.04.25		1,509.64	287,586.20
12/05/2025			Deposit	2,606.46		290,192.66
12/05/2025			Deposit	1,680,936.08		1,971,128.74
12/09/2025	1385	Agnieszka Fisher	BOS Meeting 12/3/25		200.00	1,970,928.74
12/09/2025	1386	Heather Hepner	BOS Meeting 12/3/25		200.00	1,970,728.74
12/09/2025	1387	Holly Ruhlig	BOS Meeting 12/3/25		200.00	1,970,528.74
12/09/2025	1388	John Staples	BOS Meeting 12/3/25		200.00	1,970,328.74
12/09/2025	1389	Virginia B. Edwards	BOS Meeting 12/3/25		200.00	1,970,128.74
12/10/2025	100987	Cooper Pools Inc.	Invoice: 2025-1532 (Reference: Monthly Pool Service Dec 25.) Invoice: 2025-1543 (Reference: P...		5,135.80	1,964,992.94
12/10/2025	100988	Fitness Logic	Invoice: 127309 (Reference: Fitness Equipment Monthly Maintenance.)		125.00	1,964,867.94
12/10/2025	100989	Pasco Sheriff's Office	Invoice: I-202511-12247 (Reference: Security Nov 25.)		2,480.00	1,962,387.94
12/10/2025	100990	Sunrise Propane	Invoice: U111K681 (Reference: Propane.) Invoice: U003T856 (Reference: Propane.)		2,412.80	1,959,975.14
12/10/2025	100991	State Wildlife Trapper, LLC	Invoice: 2091 (Reference: Hog Trapping Service.)		1,200.00	1,958,775.14
12/10/2025	100992	DCSI, Inc.	Invoice: 34490 (Reference: Access Cards.)		525.00	1,958,250.14
12/10/2025	100993	A Total Solution, Inc	Invoice: 000201818 (Reference: Fire Alarm Inspections Dec 25.)		600.00	1,957,650.14
12/10/2025	100994	Brietic Dvorak Inc	Invoice: 2222 (Reference: Engineering Services.)		1,125.00	1,956,525.14
12/10/2025	100995	Vesta Property Services, Inc	Invoice: 429744 (Reference: Amenity Management Nov 25.)		40,137.31	1,916,387.83
12/10/2025	100996	ProPet Distributors	Invoice: 2002036 (Reference: Dog Station Supplies.)		737.25	1,915,650.58
12/10/2025	100997	RedTree Landscape Systems	Invoice: 32278 (Reference: Grounds Maintenance, Irrigation Inspect, Arbor Care.)		15,000.00	1,900,650.58
12/10/2025	100998	Walt's Upholstery, Inc.	Invoice: 8315 (Reference: Deposit.)		7,070.00	1,893,580.58
12/10/2025	01ACH121025	Frontier	FiberOptic Internet 200 static IP- 20750 Wilderness Lake Blvd. 11.15.25- 12.14.25		125.98	1,893,454.60
12/11/2025	100999	Strictly Entertainment, Inc.	Invoice: 30833 (Reference: Extra Entertainment time.)		110.00	1,893,344.60
12/11/2025	101000	Finn Outdoor LLC	Invoice: 2972 (Reference: Pond Maintenance.) Invoice: 2973 (Reference: Control Structure & Dr...		43,300.00	1,850,044.60
12/11/2025	101001	Cooper Pools Inc.	Invoice: 333 (Reference: Check Heaters.)		250.00	1,849,794.60
12/11/2025	101002	GHS, LLC	Invoice: 2025-755 (Reference: Aquatic Weed Control Nov 25.)		3,981.67	1,845,812.93
12/11/2025	101003	Himes Electrical Service, Inc.	Invoice: 25234 (Reference: Replace burnt wires.)		144.70	1,845,668.23
12/11/2025	101004	Superior Sealers LLC	Invoice: INV-109 (Reference: 50% Parking Lot Cleaning Deposit.)		6,017.50	1,839,650.73
12/11/2025			Deposit	266,146.19		2,105,796.92
12/15/2025	101005	Vesta District Services	Invoice: 429998 (Reference: Management Fees Dec 25.)		7,158.50	2,098,638.42
12/15/2025	101006	PSA Horticultural	Invoice: 1646 (Reference: December 2025 Landscape Inspection.)		1,100.00	2,097,538.42
12/17/2025	101007	Straley Robin Vericker	Invoice: 27587 (Reference: General Matters Nov 25.)		1,464.00	2,096,074.42
12/17/2025	101008	A Total Solution, Inc	Invoice: 000201783 (Reference: Monthly Maintenance Agreement Nov 25.)		600.00	2,095,474.42
12/17/2025	101009	Cool Coast Heating & Cooling Inc	Invoice: 1350141 (Reference: Maintenance & Quarterly Maintenance AC.)		718.00	2,094,756.42
12/17/2025	101010	Florida Coast Equipment	Invoice: P3841005 (Reference: Parts.)		608.37	2,094,148.05
12/17/2025	01ACH121725	Frontier	Local service 7218 Night Heron Dr 11.22.25- 12.21.25		145.49	2,094,002.56
12/18/2025			Deposit	3,315.52		2,097,318.08
12/18/2025			Deposit	48,871.28		2,146,189.36
12/18/2025	EFT121825	FL Dept. of Rev.	November 2025 Sales Tax		148.88	2,146,040.48
12/18/2025			Deposit	516.05		2,146,556.53
12/22/2025			Deposit	276.06		2,146,832.59
12/24/2025	101011	A Total Solution, Inc	Invoice: 000202339 (Reference: Quarterly service charge for monitoring Security Video Alarm Syst...		1,320.00	2,145,512.59
12/24/2025	101012	Inteligy Tampa Bay LLC	Invoice: 23795 (Reference: Flat Rate Hosted Services, T-38 Faxing.)		330.00	2,145,182.59
12/24/2025	101013	Electro Sanitation Services	Invoice: INV-000160 (Reference: Weekly Cleaning @ \$525/week 11/1-11/30.) Invoice: INV-000161 ...		2,824.76	2,142,357.83
12/24/2025	101014	Sunrise Propane	Invoice: U111K740 (Reference: 735.3 Gal Propane.)		1,882.37	2,140,475.46
12/24/2025	101015	Rentalex of Pasco	Invoice: 4-225501 (Reference: SCISSOR LIFT 20' VERTICAL SJ20 SKY.)		501.25	2,139,974.21

Date	Number	Name	Memo	Deposits	Payments	Balance
12/24/2025	101016	Fitness Logic	Invoice: 127602 (Reference: Dec Monthly Cleaning.)		125.00	2,139,849.21
12/24/2025	101017	State Wildlife Trapper, LLC	Invoice: 2094 (Reference: Service for December 2025.)		1,380.00	2,138,469.21
12/24/2025	101018	Arrow Exterminators	Invoice: 65043442 (Reference: Commercial Pest Service.)		158.00	2,138,311.21
12/24/2025	101019	Ready Refresh	Invoice: 25L0006240923 (Reference: water service.)		47.98	2,138,263.23
12/24/2025	01ACH122425	Pasco County Utilities	0 Waverly Shores Lane 10.14.25 - 11.13.25		11.00	2,138,252.23
12/24/2025	02ACH122425	Pasco County Utilities	7639 Grasmere Dr 10.14.25 - 11.13.25		11.00	2,138,241.23
12/24/2025	03ACH122425	Pasco County Utilities	21539 Cormorant Cove Dr 10.14.25 - 11.13.25		11.00	2,138,230.23
12/24/2025	04ACH122425	Pasco County Utilities	0 Whispering Wind Dr. 10.14.25- 11.13.25		11.00	2,138,219.23
12/24/2025	05ACH122425	Pasco County Utilities	21922 Waverly Shores Lane 10.14.25 - 11.13.25		136.56	2,138,082.67
12/24/2025	06ACH122425	Pasco County Utilities	21320 Wilderness Lake Blvd 10.14.25 - 11.13.25		824.24	2,137,258.43
12/24/2025	07ACH122425	Pasco County Utilities	20750 Wilderness Lake Blvd 10.14.25 - 11.13.25		34.42	2,137,224.01
12/26/2025	01ACH122625	Waste Connections Of Florida	Monthly Fee - 01.01.26- 01.31.26		791.47	2,136,432.54
12/29/2025	01ACH122925	Duke Energy	Summary Account 10.29.25 - 11.24.25		13,618.40	2,122,814.14
12/29/2025	02ACH122925	Duke Energy	7973 Citrus Blossom Dr- Herons Glen 11.05.25-12.02.25		30.80	2,122,783.34
12/31/2025			Interest	162.37		2,122,945.71
12/31/2025	End of Month			2,002,830.01	189,608.12	2,122,945.71
01/02/2026	01ACH010226	Frontier	Business Fiber Internet - 21320 Wilderness Lake Blvd.12.07.25- 1.06.25		428.99	2,122,516.72
01/02/2026	02ACH010226	Duke Energy	Summary Bill account 11.05.25- 12.02.25		1,298.05	2,121,218.67
01/05/2026	101020	City Electric Supply Company	Invoice: LOL/220157 (Reference: Description STEM & SWIVEL MNT PHOTO CNTRL SIDE.)		26.50	2,121,192.17
01/05/2026	101021	Sunrise Propane	Invoice: U111K833 (Reference: 505.4 gal propane.)		1,293.82	2,119,898.35
01/05/2026	01ACH010526	BANK UNITED VISA CC	Office Supplies and special events		4,482.42	2,115,415.93
01/05/2026			Funds Transfer		1,700,000.00	415,415.93
01/07/2026	1390	City Electric Supply Company	VCC not processed for Ck#100964 for invoice LOL/218036 for City Electric Supply - refunded to th...		276.06	415,139.87
01/08/2026			Deposit	518.66		415,658.53
01/09/2026	101022	McNatt's Cleaners	Invoice: 77244 (Reference: Dec25 Laundry.)		41.80	415,616.73
01/09/2026	101023	Vesta District Services	Invoice: 430316 (Reference: JAN26 District Management services.)		7,158.50	408,458.23
01/09/2026	101024	RedTree Landscape Systems	Invoice: 32543 (Reference: JAN26 Grounds and Irrigation Maintenance.) Invoice: 32693 (Referen...		15,286.51	393,171.72
01/09/2026	101025	Breltic Dvorak Inc	Invoice: 2257 (Reference: Dec25 District Engineer services.)		2,715.00	390,456.72
01/09/2026	101026	Pasco Sheriff's Office	Invoice: I-202512-12490 (Reference: DEC25 security.)		2,240.00	388,216.72
01/09/2026	101027	Cooper Pools Inc.	Invoice: 2026-1070 (Reference: Monthly Commercial Maintenance January 2026.)		3,778.50	384,438.22
01/09/2026	101028	Fitness Logic	Invoice: 127767 (Reference: Fitness equipment repairs and labor.)		145.99	384,292.23
01/09/2026	01ACH010926	Frontier	FiberOptic Internet 200 static IP- 20750 Wilderness Lake Blvd. 12.15.25- 01.14.26		125.98	384,166.25
01/09/2026			Deposit	47,897.14		432,063.39
01/09/2026			Deposit	19,435.13		451,498.52
01/09/2026			Deposit	1,802.60		453,301.12
01/12/2026	1391	Heather Hepner	BOS Meeting 1/7/26		200.00	453,101.12
01/12/2026	1392	Holly Ruhlig	BOS Meeting 1/7/26		200.00	452,901.12
01/12/2026	1393	John Staples	BOS Meeting 1/7/26		200.00	452,701.12
01/12/2026	1394	Virginia B. Edwards	BOS Meeting 1/7/26		200.00	452,501.12
01/13/2026	1395	Site Masters Of Florida LLC	Pond 20 Dredging		4,250.00	448,251.12
01/14/2026	1396	Himes Electrical Service, Inc.	Returned check 100857 dated 8/11/25 refunded 9/18/25		518.66	447,732.46
01/14/2026	1397	Himes Electrical Service, Inc.	VCC not processed for ck#100965 for invoice 21517 for Himes Electrical was refunded to the bank		516.05	447,216.41
01/15/2026	101029	Vesta Property Services, Inc	Invoice: 430465 (Reference: Dec25 Management fees.)		45,768.48	401,447.93
01/15/2026	101030	Full Vessel	Invoice: 1828 (Reference: Jan. 2026 Wine Tasting.)		480.71	400,967.22
01/15/2026	101031	PSA Horticultural	Invoice: 1652 (Reference: January 2026 Landscape Inspection.)		1,100.00	399,867.22
01/16/2026	1398	Site Masters Of Florida LLC	Pond 20 Dredging - Final		4,250.00	395,617.22
01/16/2026	01ACH011626	Frontier	Local service 7218 Night Heron Dr 12.22.25- 01.21.26		145.49	395,471.73
01/16/2026	EFT011626	FL Dept. of Rev.	December 2025 Sales Tax		131.19	395,340.54
01/20/2026	101032	GHS, LLC	Invoice: 2026-135 (Reference: Monthly Weed Control Dec 25.)		3,981.67	391,358.87
01/20/2026	101033	Himes Electrical Service, Inc.	Invoice: 25197-a (Reference: Service Call on wall pack.)		516.05	390,842.82
01/20/2026	101034	Straley Robin Vericker	Invoice: 27797 (Reference: General matters Dec 25.)		2,506.89	388,335.93
01/20/2026	101035	ProPet Distributors	Invoice: 2002544 (Reference: Dog Waste Bags.)		1,160.16	387,175.77
01/20/2026	101036	RedTree Landscape Systems	Invoice: 32772 (Reference: Irrigation Repairs.)		229.25	386,946.52
01/22/2026	1399	Ellen L Dobson - Petty Cash			289.05	386,657.47
01/22/2026	101037	Ready Refresh	Invoice: 26A0006240923 (Reference: water service 12.09.25- 01.08.26.)		248.85	386,408.62
01/22/2026	101038	State Wildlife Trapper, LLC	Invoice: 2104 (Reference: Jan26 State Wildlife service.)		1,200.00	385,208.62
01/22/2026	101039	Illuminations Holiday Lighting, LLC	Invoice: 321225 (Reference: Wilderness Lakes Holiday Lighting and Decorations.)		6,000.00	379,208.62
01/22/2026	101040	RedTree Landscape Systems	Invoice: 32800 (Reference: Irrigation repairs were performed as follows on 11.13.25.) Invoice...		290.12	378,918.50
01/22/2026	101041	Inteligy Tampa Bay LLC	Invoice: 23920 (Reference: Flat Rate Hosted Services, T-38 Faxing.)		330.00	378,588.50
01/22/2026	101042	Electro Sanitation Services	Invoice: INV-000167 (Reference: Cleaning @\$525/week 12/1-12/31.) Invoice: INV-000168 (Referen...		2,881.62	375,706.88
01/22/2026	101043	Cooper Pools Inc.	Invoice: 1124 (Reference: Flowmeter.)		197.97	375,508.91
01/23/2026	01ACH012326	Waste Connections Of Florida	Monthly Fee - 02.01.26- 02.28.26		785.49	374,723.42
01/28/2026	01ACH012826	Pasco County Utilities	21539 Cormorant Cove Dr 11.13.25- 12.15.25		11.00	374,712.42

Date	Number	Name	Memo	Deposits	Payments	Balance
01/28/2026	02ACH012826	Pasco County Utilities	7639 Grasmere Dr 11.13.25- 12.15.25		11.00	374,701.42
01/28/2026	03ACH012826	Pasco County Utilities	0 Waverly Shores Lane 11.13.25- 12.15.25		11.00	374,690.42
01/28/2026	04ACH012826	Pasco County Utilities	0 Whispering Wind Dr. 11.13.25- 12.15.25		11.00	374,679.42
01/28/2026	05ACH012826	Pasco County Utilities	21922 Waverly Shores Lane 11.13.25- 12.15.25		31.82	374,647.60
01/28/2026	06ACH012826	Pasco County Utilities	20750 Wilderness Lake Blvd 11.13.25- 12.15.25		34.42	374,613.18
01/28/2026	07ACH012826	Pasco County Utilities	21320 Wilderness Lake Blvd 11.13.25- 12.15.25		1,022.96	373,590.22
01/29/2026	101044	Fitness Logic	Invoice: 128115 (Reference: Quarterly General Maintenance and cleaning of all bikes JAN26.)		125.00	373,465.22
01/29/2026	101045	Sunrise Propane	Invoice: U111L368 (Reference: 392.6 gal Propane.)		1,005.06	372,460.16
01/29/2026	101046	McNatt Plumbing Company LLC	Invoice: 44256402 (Reference: Gym and men's restroom service.) Invoice: 44288902 (Reference: ...		461.65	371,998.51
01/29/2026	101047	Himes Electrical Service, Inc.	Invoice: 25317 (Reference: Replace all 10 recessed lights outside of the activity center..) I...		1,398.15	370,600.36
01/29/2026	101048	Pasco Sheriff's Office	Invoice: I-20261-12491 (Reference: JAN26 Off Duty Deputy.)		1,920.00	368,680.36
01/30/2026	01ACH013026	Duke Energy	Summary Account 11.25.25- 12.26.25		13,928.30	354,752.06
01/30/2026	02ACH013026	Duke Energy	7973 Citrus Blossom Dr- Herons Glen 12.03.25- 01.05.26		30.80	354,721.26
01/31/2026			Interest	56.58		354,777.84
1/31/2026	End of Month			69,710.11	1,837,877.98	354,777.84
02/03/2026	01ACH020326	Frontier	Business Fiber Internet - 21320 Wilderness Lake Blvd. 01.07.26- 02.06.26		428.88	354,348.96
02/04/2026	01ACH020426	BANK UNITED VISA CC	office supplies and special event items		4,832.25	349,516.71
02/04/2026	1400	Site Masters Of Florida LLC	Replace deteriorated grate on outfall structure BB-C1		3,500.00	346,016.71
02/04/2026	1401	Site Masters Of Florida LLC	Repair pond erosion Draycott Way		1,200.00	344,816.71
02/04/2026	101049	Vesta District Services	Invoice: 430661 (Reference: FEB26 District Management services.)		7,158.50	337,658.21
02/04/2026	101050	Himes Electrical Service, Inc.	Invoice: 25331 (Reference: Install 3 new outlets, using existing circuit.)		432.00	337,226.21
02/04/2026	101051	RedTree Landscape Systems	Invoice: 32854 (Reference: Irrigation repair.) Invoice: 32853 (Reference: Irrigation repair.)		505.25	336,720.96
02/04/2026	101052	City Electric Supply Company	Invoice: LOLJ218036A (Reference: 15W LED KNUCKLE MNTD FLD LGT DLC RATED.)		258.00	336,462.96
02/04/2026	101053	Blue Line Tree Company	Invoice: 26-2039 (Reference: Removal of Dead trees.) Invoice: 26-2038 (Reference: Removal of ...		7,350.00	329,112.96
02/05/2026	101054	Romaner Graphics	Invoice: 22955 (Reference: lodge repairs.)		1,900.00	327,212.96
02/05/2026	01ACH020526	Duke Energy	Summary Bill account 12.03.25- 01.05.26		1,836.11	325,376.85
02/06/2026	101055	Cooper Pools Inc.	Invoice: 2026-1164 (Reference: Monthly Commercial Maintenance February 2026.) Invoice: 444 (R...		4,222.50	321,154.35
02/06/2026	101056	GHS, LLC	Invoice: 2026-178 (Reference: Monthly Aquatic Weed Control.)		3,981.67	317,172.68
02/06/2026	101057	RedTree Landscape Systems	Invoice: 32454 (Reference: Landscape Construction.) Invoice: 32412 (Reference: Irrigation rep...		20,186.10	296,986.58
02/06/2026	101058	Vesta Property Services, Inc	Invoice: 430870 (Reference: JAN26 District Management services.)		39,685.13	257,301.45
02/06/2026	101059	Sunrise Propane	Invoice: I017622 (Reference: 304.60 gal Propane.) Invoice: U003U007 (Reference: 661.6 Propane...		2,473.48	254,827.97
02/09/2026	101060	Cooper Pools Inc.	Invoice: 455 (Reference: Replacement Pentair Tank Body.)		885.54	253,942.43
02/09/2026	101061	Palm Beach Security & Safe, Inc.	Invoice: 12829 (Reference: lodge repairs.)		572.80	253,369.63
02/09/2026	101062	Breltic Dvorak Inc	Invoice: 2317 (Reference: Engineering services.)		855.00	252,514.63
02/09/2026	101063	RedTree Landscape Systems	Invoice: 32961 (Reference: Grounds Maintenance, irrigation and arbor careFeb26.)		15,000.00	237,514.63
02/09/2026	101064	Blue Line Tree Company	Invoice: 26-2037 (Reference: Dead Tree Removal.)		9,800.00	227,714.63
02/10/2026	1402	Agnieszka Fisher	BOS Meeting 2/04/26		200.00	227,514.63
02/10/2026	1403	Holly Ruhlig	BOS Meeting 2/04/26		200.00	227,314.63
02/10/2026	1404	John Staples	BOS Meeting 2/04/26		200.00	227,114.63
02/10/2026	1405	Virginia B. Edwards	BOS Meeting 2/04/26		200.00	226,914.63
02/10/2026	01ACH021026	Frontier	FiberOptic Internet 200 static IP- 20750 Wilderness Lake Blvd. 01.15.26- 02.14.26		125.98	226,788.65
02/11/2026	101065	Himes Electrical Service, Inc.	Invoice: 25347 (Reference: Irrigation repair.)		888.12	225,900.53
02/11/2026	101066	Cooper Pools Inc.	Invoice: 464 (Reference: Install new Century Motor and PS201 Seal.)		732.34	225,168.19
02/11/2026	101067	McNatt's Cleaners	Invoice: 78063 (Reference: Laundry.)		53.20	225,114.99
02/11/2026	101068	McNatt Plumbing Company LLC	Invoice: 44471430 (Reference: Urinal backing up in men's bathroom.)		185.00	224,929.99
02/11/2026			Deposit	30,220.30		255,150.29
02/11/2026			Deposit	1,477.53		256,627.82
02/18/2026	1406	Site Masters Of Florida LLC	Vegetation Overgrowth removal Pond 1		2,800.00	253,827.82
02/18/2026	1407	Site Masters Of Florida LLC	Sediment removal Pond 1		3,200.00	250,627.82
02/18/2026	01ACH021826	Frontier	Local service 7218 Night Heron Dr 01.22.26- 02.21.26		145.49	250,482.33
02/18/2026	101069	Cooper Pools Inc.	Invoice: 470 (Reference: Commercial Installation / Repairs.)		113.23	250,369.10
02/18/2026	101070	Straley Robin Vericker	Invoice: 27898 (Reference: Professional Services Rendered Through January 31, 2026.)		915.00	249,454.10
02/18/2026	101071	Head's Flags Inc.	Invoice: 25226 (Reference: Rope and two brass snaps.)		55.70	249,398.40
02/18/2026	101072	PSA Horticultural	Invoice: 1666 (Reference: February 2026 Landscape Inspection.)		1,100.00	248,298.40
02/18/2026	101073	A Total Solution, Inc	Invoice: 000202385 (Reference: Feb26 Monthly Maintenance Agreement.)		600.00	247,698.40
02/20/2026	101074	A Total Solution, Inc	Invoice: i8325 (Reference: Quarterly Wet System Insp.) Invoice: i8326 (Reference: Annual Fire...		165.00	247,533.40
02/20/2026	101075	DCSI, Inc.	Invoice: 34807 (Reference: Camera installation.)		599.00	246,934.40
02/23/2026	101076	Arrow Exterminators	Invoice: 65804500 (Reference: Commercial Pest Service.)		158.00	246,776.40
02/23/2026	101077	Cooper Pools Inc.	Invoice: 484 (Reference: Commercial Installation / Repairs.)		121.65	246,654.75
02/23/2026	101078	Ready Refresh	Invoice: 26B0006240923 (Reference: water service 2/3- 3/2.)		47.98	246,606.77
02/23/2026	101079	RedTree Landscape Systems	Invoice: 33219 (Reference: Irrigation repair.)		1,440.95	245,165.82
02/23/2026	101080	State Wildlife Trapper, LLC	Invoice: 2116 (Reference: FEB26 Wildlife service.)		1,200.00	243,965.82
02/23/2026	101081	Inteligy Tampa Bay LLC	Invoice: 24057 (Reference: Flat Rate Hosted Services, T-38 Faxing.)		330.00	243,635.82

Date	Number	Name	Memo	Deposits	Payments	Balance
02/23/2026	101082	Electro Sanitation Services	Invoice: INV-000173 (Reference: Weekly Cleaning @\$525/week 1/1-1/31.) Invoice: INV-000174 (Re...		2,423.76	241,212.06
02/23/2026	101083	Strictly Entertainment, Inc.	Invoice: 30862 (Reference: Face Painter 2p-3:30p.)		295.00	240,917.06
02/23/2026	EFT022326	FL Dept. of Rev.	January 2026 Sales Tax		215.80	240,701.26
02/24/2026	01ACH022425	Waste Connections Of Florida	Monthly Fee - 03.01.26- 03.31.26		772.85	239,928.41
02/25/2026	01ACH022526	Pasco County Utilities	21922 Waverly Shores Lane 12.15.26- 01.13.26		31.82	239,896.59
02/25/2026	02ACH022526	Pasco County Utilities	7639 Grasmere Dr 12.15.26- 01.13.26		11.00	239,885.59
02/25/2026	03ACH022526	Pasco County Utilities	21539 Cormorant Cove Dr 12.15.26- 01.13.26		11.00	239,874.59
02/25/2026	04ACH022526	Pasco County Utilities	20750 Wilderness Lake Blvd 12.15.25- 01.13.26		34.42	239,840.17
02/25/2026	05ACH022526	Pasco County Utilities	0 Waverly Shores Lane 12.15.25- 01.13.26		11.00	239,829.17
02/25/2026	06ACH022526	Pasco County Utilities	21320 Wilderness Lake Blvd 12.15.25- 01.13.26		956.72	238,872.45
02/25/2026	07ACH022526	Pasco County Utilities	0 Whispering Wind Dr. 12.15.25- 01.13.26		38.76	238,833.69
02/25/2026	101084	Cooper Pools Inc.	Invoice: 1125 (Reference: 6" MagnaLatch Vertical Pull Gate Latch.)		263.81	238,569.88
02/25/2026	101085	Cool Coast Heating & Cooling Inc	Invoice: 021926 (Reference: lodge repairs.)		1,653.00	236,916.88
02/25/2026	101086	Sunrise Propane	Invoice: U111L947 (Reference: 273.1 GAL Propane.)		707.33	236,209.55
02/27/2026	101087	McNatt Plumbing Company LLC	Invoice: 44578702 (Reference: Proposal Work - Fitness Center.)		2,077.00	234,132.55
02/28/2026			Interest	24.38		234,156.93
2/28/2026		End of Month		31,722.21	152,343.12	234,156.93
03/02/2026	01ACH030226	Duke Energy	Summary Account - 12.27.26- 01.27.26		14,287.65	219,869.28
03/02/2026	02ACH030226	Duke Energy	7973 Citrus Blossom Dr- Herons Glen 01.06.26- 02.03.26		30.80	219,838.48
03/04/2026	01ACH030426	Frontier	Business Fiber Internet - 21320 Wilderness Lake Blvd. 02.07.26- 03.06.26		450.86	219,387.62
03/04/2026	02ACH030426	BANK UNITED VISA CC	office supplies		3,809.58	215,578.04
03/05/2026	01ACH030526	Duke Energy	Summary Bill account 01.06.26- 02.03.26		1,301.94	214,276.10
03/06/2026	101088	A Total Solution, Inc	Invoice: 000202404 (Reference: Monthly Maintenance Agreement Mar26.)		600.00	213,676.10
03/06/2026	101089	Brietic Dvorak Inc	Invoice: 2359 (Reference: Engineering services.)		945.00	212,731.10
03/06/2026	101090	Vesta District Services	Invoice: 431106 (Reference: Management fee services Mar26.)		7,158.50	205,572.60
03/06/2026	101091	Cool Coast Heating & Cooling Inc	Invoice: 1350662 (Reference: Quarterly Maintenance and Diagnostic.)		1,470.00	204,102.60
03/06/2026	101092	Cooper Pools Inc.	Invoice: 2026-1232 (Reference: Monthly Commercial Maintenance March 2026.) Invoice: 543 (Ref...		4,158.48	199,944.12
03/06/2026	101093	Fitness Logic	Invoice: 128654 (Reference: Monthly General Maintenance and cleaning of all equipment Mar26.)		125.00	199,819.12
03/06/2026	101094	McNatt's Cleaners	Invoice: 78914 (Reference: Laundry.)		117.80	199,701.32
03/06/2026	101095	RedTree Landscape Systems	Invoice: 33261 (Reference: Grounds Maintenance, irrigation and arbor care Mar26.) Invoice: 33...		15,256.34	184,444.98
03/09/2026	1408	Holly Ruhlig	BOS Meeting 3/04/26		200.00	184,244.98
03/09/2026	1409	John Staples	BOS Meeting 3/04/26		200.00	184,044.98
03/09/2026	1410	Virginia B. Edwards	BOS Meeting 3/04/26		200.00	183,844.98
03/10/2026	1411	Pasco County Property Appraiser	Annual renewal fee		150.00	183,694.98
03/11/2026	101096	RedTree Landscape Systems	Invoice: 33396 (Reference: Flush cut of 2 dead trees at 21320 Wilderness Lake Blvd..) Invoice...		4,750.00	178,944.98
03/11/2026	101097	Vesta Property Services, Inc	Invoice: 431425 (Reference: Jan26 Management fees.)		36,346.68	142,598.30
03/11/2026	101098	Sunrise Propane	Invoice: U111M290 (Reference: 658.1 gal Propane.)		1,704.48	140,893.82
03/11/2026	101099	Brian Peters LLC	Invoice: 167 (Reference: Down payment for fascia trim and gutter replacements.)		6,000.00	134,893.82
03/11/2026	101100	Cooper Pools Inc.	Invoice: 547 (Reference: Commercial Installation / Repairs.) Invoice: 558 (Reference: Removal...		2,436.47	132,457.35
03/11/2026	101101	GHS, LLC	Invoice: 2026-240 (Reference: Routine Wetland Buffer Maintenance.)		6,072.00	126,385.35
03/11/2026	101102	Pasco Sheriff's Office	Invoice: I-20262-12615 (Reference: Feb26 Community Security.)		2,160.00	124,225.35
03/11/2026	101103	Vesta District Services	Invoice: 431356 (Reference: Billable Expenses - Feb 2026.)		40.60	124,184.75
03/12/2026	01ACH031226	Frontier	FiberOptic Internet 200 static IP- 20750 Wilderness Lake Blvd. 02.15.26- 03.14.26		125.98	124,058.77
03/12/2026			Deposit	29,074.40		153,133.17
03/12/2026			Deposit	917.57		154,050.74
03/17/2026	101104	Fitness Logic	Invoice: 128829 (Reference: Fitness equipment repairs and labor.)		320.98	153,729.76
03/17/2026	101105	PSA Horticultural	Invoice: 1675 (Reference: March 2026 Landscape Inspection.)		1,100.00	152,629.76
03/17/2026	101106	RedTree Landscape Systems	Invoice: 33475 (Reference: Center Median at U.S 41 and Wilderness Lake Blvd..) Invoice: 33474...		10,350.00	142,279.76
03/19/2026	101107	Superior Sealers LLC	Invoice: INV-125 (Reference: Final Payment.)		6,017.50	136,262.26
03/19/2026	101108	Cooper Pools Inc.	Invoice: 574 (Reference: Install Float Assembly at Splash Pad.)		317.47	135,944.79
03/19/2026	101109	Sheffield's Quality Tree Services, LLC	Invoice: 001 (Reference: Crape Myrtle Trimming.) Invoice: 002 (Reference: Crape Myrtle Trimm...		9,080.00	126,864.79
03/19/2026	101110	RedTree Landscape Systems	Invoice: 33445 (Reference: Palm Tree Trimming.)		6,000.00	120,864.79
03/19/2026	01ACH031926	Frontier	Local service 7218 Night Heron Dr 02.22.26- 03.21.26		145.49	120,719.30
03/19/2026	EFT031926	FL Dept. of Rev.	February 2026 Sales Tax		213.91	120,505.39
03/23/2026	101111	Straley Robin Vericker	Invoice: 27992 (Reference: Legal Services Feb 26.)		1,336.80	119,168.59
03/23/2026	101112	Inteligy Tampa Bay LLC	Invoice: 24181 (Reference: Hosting & Faxing Services Mar 26.)		330.00	118,838.59
03/24/2026	01ACH032426	Waste Connections Of Florida	Monthly Fee - 04.01.26- 04.30.26		788.18	118,050.41
03/24/2026	1412	Agnieszka Fisher	BOS Budget Workshop 3/20/26		200.00	117,850.41
03/24/2026	1413	Heather Hepner	BOS Budget Workshop 3/20/26		200.00	117,650.41
03/24/2026	1414	Holly Ruhlig	BOS Budget Workshop 3/20/26		200.00	117,450.41
03/24/2026	1415	John Staples	BOS Budget Workshop 3/20/26		200.00	117,250.41
03/24/2026	1416	Virginia B. Edwards	BOS Budget Workshop 3/20/26		200.00	117,050.41
03/25/2026	01ACH032526	Pasco County Utilities	0 Whispering Wind Dr. 01.13.26- 02.11.26		445.44	116,604.97

Date	Number	Name	Memo	Deposits	Payments	Balance
03/25/2026	02CH032526	Pasco County Utilities	21320 Wilderness Lake Blvd 01.13.26- 02.11.26		1,105.76	115,499.21
03/25/2026	03CH032526	Pasco County Utilities	20750 Wilderness Lake Blvd 01.13.26- 02.11.26		34.42	115,464.79
03/25/2026	04CH032526	Pasco County Utilities	21539 Cormorant Cove Dr 01.13.26- 02.11.26		11.00	115,453.79
03/25/2026	05CH032526	Pasco County Utilities	21922 Waverly Shores Lane 01.13.26- 02.11.26		35.29	115,418.50
03/25/2026	06CH032526	Pasco County Utilities	7639 Grasmere Dr 01.13.26- 02.11.26		11.00	115,407.50
03/25/2026	07CH032526	Pasco County Utilities	0 Waverly Shores Lane 01.13.26- 02.11.26		11.00	115,396.50
03/26/2026	1417	Leaders Casual Furniture	Replacement of poolside chairs		2,255.00	113,141.50
03/26/2026	101113	Cooper Pools Inc.	Invoice: 606 (Reference: Outcome 2 - Assess gas leak..)		270.00	112,871.50
03/26/2026	101114	RedTree Landscape Systems	Invoice: 33529 (Reference: SPRING SEASONAL COLOR.) Invoice: 33541 (Reference: Plant Material ...		8,652.64	104,218.86
03/26/2026	101115	Grant Hemond & Associates	Invoice: 469531 (Reference: Deposit: Community Celebration Pool Party 6.6.26.)		178.50	104,040.36
03/27/2026	101116	Sunrise Propane	Invoice: U7922548 (Reference: 547.2 gal Propane.) Invoice: U7922582 (Reference: 241.6 gal p...		2,177.09	101,863.27
03/27/2026	101117	10-S Tennis Supply & Dinkshot Pickleball	Invoice: 172110 (Reference: Green, 1 @ 6'H x 13'L, with Standard Half-moon Vents.)		83.85	101,779.42
03/27/2026	101118	Cooper Pools Inc.	Invoice: 592 (Reference: Spa ADA Chair Repair Quote.) Invoice: 593 (Reference: Check Heaters....		2,019.36	99,760.06
03/27/2026	101119	Ready Refresh	Invoice: 26C0006240923 (Reference: water service 03.03- 03.30.)		194.87	99,565.19
03/27/2026	101120	RedTree Landscape Systems	Invoice: 33542 (Reference: Landscape enhancement at rear of butterfly garden.) Invoice: 33571...		936.46	98,628.73
03/27/2026	101121	State Wildlife Trapper, LLC	Invoice: 2125 (Reference: Mar26 State wildlife service.)		1,200.00	97,428.73
03/27/2026	101122	Grant Hemond & Associates	Invoice: 469534 (Reference: Deposit: Labor Day BBQ/Pool Party.) Invoice: 469533 (Reference: D...		594.00	96,834.73
03/27/2026	101123	Blue Line Tree Company	Invoice: 26-2089 (Reference: Removal of dead Pine and Oak trees.) Invoice: 26-2088 (Reference...		2,200.00	94,634.73
03/30/2026	01ACH033026	Duke Energy	Summary Account - 01.28.26- 02.24.26		13,231.78	81,402.95
03/30/2026	02ACH033026	Duke Energy	7973 Citrus Blossom Dr- Herons Glen 02.04.26- 03.03.26		30.80	81,372.15
03/31/2026			Interest	16.32		81,388.47
3/31/2026		End of Month		30,008.29	182,776.75	81,388.47
04/01/2026	01ACH040126	Frontier	Business Fiber Internet - 21320 Wilderness Lake Blvd. 03.07.26- 04.06.26		450.86	80,937.61
04/01/2026	1418	CDW Government LLC	unlimited Cloud storage and barracuda replacement- backup		1,307.28	79,630.33
04/01/2026	1419	Strictly Entertainment, Inc.	Reference: Spring Picnic Egg-Hunts		1,800.00	77,830.33
04/02/2026	01ACH040226	Duke Energy	Summary Bill account 02.04.26- 03.03.26		1,338.41	76,491.92
04/06/2026			Funds Transfer	500,000.00		576,491.92
04/06/2026	1420	U.S. Bank Tax Distributions			446,233.19	130,258.73
04/06/2026	101124	RedTree Landscape Systems	Invoice: 33622 (Reference: Irrigation repairs - valves shut off for freeze prevention..) Invo...		15,260.00	114,998.73
04/06/2026	101125	Grant Hemond & Associates	Invoice: 469535 (Reference: FY 26/27 DJ Deposit -Fall Festival / Oktoberfest.)		238.50	114,760.23
04/06/2026	101126	Vesta Property Services, Inc	Invoice: 431607 (Reference: Management fees.)		37,804.62	76,955.61
04/06/2026	101127	City Electric Supply Company	Invoice: LOL/223853 (Reference: ption 15W LED FLOOD 5K KNUCKLE MNT BZ 120V SPST 1/2" CONDUIT MOU...		196.54	76,759.07
04/06/2026	101128	Arrow Exterminators	Invoice: 66700131 (Reference: Commercial Pest Service.)		163.00	76,596.07
04/06/2026	101129	Cooper Pools Inc.	Invoice: 1420 (Reference: Vandalism - Spa (Soap in the Jacuzzi).) Invoice: 2026-1350 (Referen...		7,407.86	69,188.21
04/06/2026	101130	Fitness Logic	Invoice: 129124 (Reference: - Labor Only Maintenance completion during March..)		125.00	69,063.21
04/06/2026	101131	Sunrise Propane	Invoice: U111M470 (Reference: 317.2 Gal Propane.)		875.47	68,187.74
04/06/2026	101132	A Total Solution, Inc	Invoice: 000202928 (Reference: Quarterly service charge for monitoring Security Video Alarm Syst...		1,320.00	66,867.74
04/06/2026	101133	Pasco Sheriff's Office	Invoice: I-20263-12618 (Reference: Security Services.)		1,680.00	65,187.74
04/06/2026	01ACH040626	BANK UNITED VISA CC			4,777.66	60,410.08
04/08/2026			Deposit	1,200.00		61,610.08
04/09/2026	101134	RedTree Landscape Systems	Invoice: 33756 (Reference: Irrigation repairs were performed as follows on 2.5.26.) Invoice: ...		788.62	60,821.46
04/09/2026	101135	GHS, LLC	Invoice: 2026-285 (Reference: APR26 Aquatic Weed Control Program.)		3,981.67	56,839.79
04/09/2026	101136	McNatt's Cleaners	Invoice: 79764 (Reference: Laundry.)		19.00	56,820.79
04/09/2026	101137	Brlitic Dvorak Inc	Invoice: 2402 (Reference: Project manager 03.04.26.)		210.00	56,610.79
04/09/2026	101138	Vesta District Services	Invoice: 431787 (Reference: Apr26 Management fees.)		7,158.50	49,452.29
04/09/2026	101139	Tampa Bay Times	Invoice: 040426-5481 (Reference: Renewal 5/3/26- 5/2/27.)		239.20	49,213.09
04/09/2026	101140	Sunrise Propane	Invoice: U111M600 (Reference: 242.8 gal Propane.)		684.70	48,528.39
04/09/2026	01ACH040926	Frontier	FiberOptic Internet 200 static IP- 20750 Wilderness Lake Blvd. 03.15.26- 04.14.26		125.98	48,402.41
04/09/2026			Deposit	261.46		48,663.87
04/09/2026			Deposit	51,708.13		100,372.00
04/09/2026			Deposit	26,111.61		126,483.61
04/15/2026	101141	PSA Horticultural	Invoice: 1682 (Reference: April 2026 Landscape Inspection.)		1,100.00	125,383.61
04/15/2026	101142	Romaner Graphics	Invoice: 23057 (Reference: 21" x 29" laminated Wilderness Lake Preserve Logo - Mounted on Drink...		1,235.00	124,148.61
04/15/2026	101143	Sunrise Propane	Invoice: U111M755 (Reference: 296.0 Gal Propane.)		834.72	123,313.89
04/15/2026	101144	Electro Sanitation Services	Invoice: INV-000180 (Reference: Cleaning @\$525/week.) Invoice: INV-000183 (Reference: Janitor...		2,695.68	120,618.21
04/15/2026	101145	Rentalax of Pasco	Invoice: 4-229386 (Reference: SCISSOR LIFT 20' VERTICAL SJ20 SKY.)		501.25	120,116.96
04/16/2026	1421	Heather Hepner	BOS Meeting 4/1/26		200.00	119,916.96
04/16/2026	1422	Holly Ruhlig	BOS Meeting 4/1/26		200.00	119,716.96
04/16/2026	1423	John Staples	BOS Meeting 4/1/26		200.00	119,516.96
04/16/2026	1424	Virginia B. Edwards	BOS Meeting 4/1/26		200.00	119,316.96
04/16/2026	01ACH041626	Frontier	Local service 7218 Night Heron Dr 03.22.26- 04.21.26		145.49	119,171.47
04/17/2026	EFT041726	FL Dept. of Rev.	March 2026 Sales Tax		272.31	118,899.16
04/21/2026	101146	Cooper Pools Inc.	Invoice: 1522 (Reference: Escutcheon Chrome Clip On.)		95.19	118,803.97

Date	Number	Name	Memo	Deposits	Payments	Balance
04/21/2026	101147	GHS, LLC	Invoice: 2026-307 (Reference: Wetland Buffer Maintenance Mar 26.)		2,200.00	116,603.97
04/21/2026	101148	Ready Refresh	Invoice: 26D0006240923 (Reference: Admin Fee.)		47.98	116,555.99
04/21/2026	101149	Straley Robin Vericker	Invoice: 28220 (Reference: Legal Services Mar 26.)		3,728.78	112,827.21
04/21/2026	101150	Romaner Graphics	Invoice: 23074 (Reference: Replace Cultured Stone.) Invoice: 23073 (Reference: Repair Vinyl G...		713.00	112,114.21
04/21/2026	101151	10-S Tennis Supply & Dinkshot Pickleball	Invoice: 173240 (Reference: Net Strap.)		47.44	112,066.77
04/21/2026	101152	State Wildlife Trapper, LLC	Invoice: 2137 (Reference: Trapping Services Apr 26.)		1,200.00	110,866.77
04/21/2026	101153	Inteligy Tampa Bay LLC	Invoice: 24626 (Reference: Hosting & Faxing Services Apr 26.)		330.00	110,536.77
04/21/2026	101154	Electro Sanitation Services	Invoice: INV-000189 (Reference: Janitorial Supplis.) Invoice: INV-000188 (Reference: Janitor...		2,675.46	107,861.31
04/21/2026	101155	Rentalex of Pasco	Invoice: 4-229426 (Reference: Scissor Lift Rental.)		563.25	107,298.06
04/22/2026	01ACH042226	Pasco County Utilities	0 Whispering Wind Dr. 02.11.26- 03.13.26		510.96	106,787.10
04/22/2026	02ACH042226	Pasco County Utilities	21922 Waverly Shores Lane 02.11.26- 03.13.26		80.40	106,706.70
04/22/2026	03ACH042226	Pasco County Utilities	7639 Grasmere Dr 02.11.26- 03.13.26		11.00	106,695.70
04/22/2026	04ACH042226	Pasco County Utilities	21539 Cormorant Cove Dr 02.11.26- 03.13.26		11.00	106,684.70
04/22/2026	05ACH042226	Pasco County Utilities	20750 Wilderness Lake Blvd 02.11.26- 03.13.26		34.42	106,650.28
04/22/2026	06ACH042226	Pasco County Utilities	0 Waverly Shores Lane 02.11.26- 03.13.26		11.00	106,639.28
04/22/2026	07ACH042226	Pasco County Utilities	21320 Wilderness Lake Blvd 02.11.26- 03.13.26		2,033.12	104,606.16
04/23/2026	1425	Mike Fasano, Pasco County Tax Collector	Parcel ID # 36-25-18-0010-00000-RC10, 2026 Solid Waste Assessment		5,870.86	98,735.30
04/23/2026	01ACH042326	Waste Connections Of Florida	Monthly Fee - 05.01.26- 05.31.26		874.14	97,861.16
04/29/2026	1426	Leaders Casual Furniture	Poolside replacement umbrellas		796.97	97,064.19
04/30/2026	01ACH043026	Duke Energy	Summary Account -02.25.26- 03.26.26		13,005.08	84,059.11
04/30/2026	02ACH043026	Duke Energy	7973 Citrus Blossom Dr- Herons Glen 03.04.26- 04.02.26		30.80	84,028.31
04/30/2026			Interest	22.58		84,050.89
4/30/2026		End of Month		579,303.78	576,641.36	84,050.89
05/04/2026			Funds Transfer	140,000.00		224,050.89
05/04/2026	01ACH050426	Frontier	Business Fiber Internet - 21320 Wilderness Lake Blvd. 04.07.26- 05.06.26		450.69	223,600.20
05/04/2026	02ACH050426	BANK UNITED VISA CC	office supplies		3,881.14	219,719.06
05/04/2026	101156	A Total Solution, Inc	Invoice: 000203001 (Reference: annual Fire Alarm inspections, Fire Sprinkler inspections and bie...		600.00	219,119.06
05/04/2026	101157	Pasco Sheriff's Office	Invoice: I-20264-12722 (Reference: Security Services.)		2,200.00	216,919.06
05/04/2026	101158	McNatt Plumbing Company LLC	Invoice: 45411590 (Reference: Women's locker room has a faucet that is loose and leaking..)		185.00	216,734.06
05/04/2026	101159	Romaner Graphics	Invoice: 23078 (Reference: Installation of speaker in Activity Center. Troubleshoot and rewire ...		650.00	216,084.06
05/04/2026	101160	Himes Electrical Service, Inc.	Invoice: 25495 (Reference: Pool repair.)		163.75	215,920.31
05/04/2026	101161	RedTree Landscape Systems	Invoice: 33907 (Reference: Irrigation repair- Water Edge Timer replaced..) Invoice: 33915 (Re...		15,310.56	200,609.75
05/04/2026	101162	DCSI, Inc.	Invoice: 35080 (Reference: Access Cards and tested HDD.)		670.00	199,939.75
05/04/2026	101163	CDW Government LLC	Invoice: 042226 (Reference: office supplies.)		301.50	199,638.25
05/04/2026	101164	Arrow Exterminators	Invoice: 66908282 (Reference: Pest Control Service.)		1,185.00	198,453.25
05/04/2026	101165	Cooper Pools Inc.	Invoice: 1530 (Reference: SR Smith Lift Operator Battery.)		547.22	197,906.03
05/04/2026	101166	Fitness Logic	Invoice: 129573 (Reference: Monthly General Maintenance and cleaning of all equipment.)		125.00	197,781.03
05/04/2026	101167	Palm Beach Security & Safe, Inc.	Invoice: 12874 (Reference: Lodge Door Maint..)		522.00	197,259.03
05/06/2026	01ACH050626	Duke Energy	Summary Bill account 03.04.26- 04.02.26		1,424.27	195,834.76
05/07/2026	101168	FitRev Inc	Invoice: 38644 (Reference: 2 Treadmills.)		14,495.40	181,339.36
05/11/2026	101169	Vesta District Services	Invoice: 432291 (Reference: Apr26 Management fees.)		40,915.28	140,424.08
05/11/2026	101170	Cooper Pools Inc.	Invoice: 2026-1440 (Reference: Monthly Commercial Maintenance May 2026.) Invoice: 731 (Referenc...		7,532.89	132,891.19
05/11/2026	101171	McNatt's Cleaners	Invoice: 80602 (Reference: Laundry.)		60.80	132,830.39
05/11/2026	101172	Palm Beach Security & Safe, Inc.	Invoice: 12881 (Reference: Ladies room pool repair.)		476.00	132,354.39
05/11/2026	101173	Himes Electrical Service, Inc.	Invoice: 25391 (Reference: Service call- 3/11.)		140.00	132,214.39
05/11/2026	101174	RedTree Landscape Systems	Invoice: 34077 (Reference: PINE TREE REMOVAL -7550 Grasmere Drive..) Invoice: 34078 (Referenc...		2,100.00	130,114.39
05/11/2026	101175	DCSI, Inc.	Invoice: 35092 (Reference: Camera/DVR Service.)		494.00	129,620.39
05/11/2026	101176	Sunrise Propane	Invoice: U111N226 ()		679.16	128,941.23
05/11/2026	101177	10-S Tennis Supply & Dinkshot Pickleball	Invoice: 175392 (Reference: Wilson US Open Hard Court Extra Duty Balls - Case of 72 balls.)		151.89	128,789.34
05/12/2026	01ACH051226	Frontier	FiberOptic Internet 200 static IP- 20750 Wilderness Lake Blvd. 04.15.26- 05.14.26		125.98	128,663.36
05/12/2026			Deposit	4,632.72		133,296.08
05/13/2026	101178	Brietic Dvorak Inc	Invoice: 2411 (Reference: Engineering services.)		945.00	132,351.08
05/13/2026	101179	Vesta District Services	Invoice: 432480 (Reference: Management fee services May26.)		7,158.50	125,192.58
05/13/2026	101180	10-S Tennis Supply & Dinkshot Pickleball	Invoice: 175471 (Reference: (Bag of 100) Aluminum Fence Tys 8 1/4".)		68.89	125,123.69
05/13/2026	101181	RedTree Landscape Systems	Invoice: 34138 (Reference: PINE TREES REMOVAL -7919 Citrus Blossom Dr..)		800.00	124,323.69
05/13/2026	101182	CDW Government LLC	Invoice: PV2L231 (Reference: SonicWall Advanced Protection Service Suite - subscription license ...		1,621.59	122,702.10
05/18/2026	101183	Agnieszka Fisher	Invoice: 050726 BOS (Reference: BOS Meeting 5/7/26.)		200.00	122,502.10
05/18/2026	101184	Cooper Pools Inc.	Invoice: 761 (Reference: Install Light at Resort Pool.) Invoice: 760 (Reference: Remove & Ins...		9,397.92	113,104.18
05/18/2026	101185	Fitness Logic	Invoice: 129836 (Reference: Pedal wheels- Replace (2) Pedal wheels on Precor Elliptical.)		350.98	112,753.20
05/18/2026	101186	GHS, LLC	Invoice: 2026-362 (Reference: Monthly Aquatic Weed Control Services.)		6,181.67	106,571.53
05/18/2026	101187	Holly Ruhlig	Invoice: 050726 BOS (Reference: BOS Meeting 5/7/26.)		200.00	106,371.53
05/18/2026	101188	Straley Robin Vericker	Invoice: 28327 (Reference: Professional Services Rendered Through April 30, 2026.)		810.50	105,561.03
05/18/2026	101189	Cool Coast Heating & Cooling Inc	Invoice: 1351274 (Reference: Service call 5.13.26.)		488.00	105,073.03

Date	Number	Name	Memo	Deposits	Payments	Balance
05/18/2026	101190	PSA Horticultural	Invoice: 1694 (Reference: May 2026 Landscape Inspection.)		1,100.00	103,973.03
05/18/2026	101191	Virginia B. Edwards	Invoice: 050726 BOS (Reference: BOS Meeting 5/7/26.)		200.00	103,773.03
05/18/2026	101192	RedTree Landscape Systems	Invoice: 34158 (Reference: Irrigation repairs-Repairs to zone 11..) Invoice: 34157 (Reference...		498.98	103,274.05
05/18/2026	101193	Inteligy Tampa Bay LLC	Invoice: 24743 (Reference: Flat Rate Hosted Services, T-38 Faxing.)		330.00	102,944.05
05/18/2026	101194	John Staples	Invoice: 050726 BOS (Reference: BOS Meeting 5/7/26.)		200.00	102,744.05
05/18/2026	101195	A Total Solution, Inc	Invoice: i10178 (Reference: SemiAnnual Wet System Insp.) Invoice: i10205 (Reference: SemiAnnu...		74.00	102,670.05
05/18/2026	101196	Heather Hepner	Invoice: 050726 BOS (Reference: BOS Meeting 5/7/26.)		200.00	102,470.05
05/19/2026	01ACH051926	Frontier	Local service 7218 Night Heron Dr 04.22.26- 05.21.26 NEED BACKUP		145.49	102,324.56
05/20/2026	EFT052026	FL Dept. of Rev.	April 2026 Sales Tax		262.21	102,062.35
05/21/2026	101197	RedTree Landscape Systems	Invoice: 34256 (Reference: FLUSH CUT AND INSTALLATION FROM APPROVED PROPOSAL.) Invoice: 34255...		9,744.00	92,318.35
05/21/2026	101198	State Wildlife Trapper, LLC	Invoice: 2149 (Reference: May 2026.)		1,200.00	91,118.35
05/21/2026	101199	Electro Sanitation Services	Invoice: INV-000194 (Reference: Janitor supplies.) Invoice: INV-000193 (Reference: Weekly Cle...		2,499.81	88,618.54
05/21/2026	101200	Cooper Pools Inc.	Invoice: 768 (Reference: AMP Draw was good, capacitor needs replaced.)		420.00	88,198.54
05/21/2026	101201	Ready Refresh	Invoice: 36D0006240923 (Reference: 4.28.26- 5.25.26.)		47.98	88,150.56
05/21/2026	101202	10-S Tennis Supply & Dinkshot Pickleball	Invoice: 175674 (Reference: 1 @ 6'H x 44'2"L, Green, with Standard Half-Moon Vents.)		306.98	87,843.58
05/22/2026	1427	Ellen L Dobson - Petty Cash			294.09	87,549.49
05/22/2026	101203	ProPet Distributors	Invoice: 2003522 (Reference: Dog waste station supplies.)		1,160.16	86,389.33
05/26/2026	01ACH052626	Pasco County Utilities	0 Whispering Wind Dr. 03.13.26- 04.14.26		333.12	86,056.21
05/26/2026	02ACH052626	Pasco County Utilities	21922 Waverly Shores Lane 03.13.26- 04.14.26		89.76	85,966.45
05/26/2026	03ACH052626	Pasco County Utilities	7639 Grasmere Dr 03.13.26- 04.14.26		11.00	85,955.45
05/26/2026	04ACH052626	Pasco County Utilities	21539 Cormorant Cove Dr 03.13.26- 04.14.26		11.00	85,944.45
05/26/2026	05ACH052626	Pasco County Utilities	20750 Wilderness Lake Blvd 03.13.26- 04.14.26		34.42	85,910.03
05/26/2026	06ACH052626	Pasco County Utilities	0 Waverly Shores Lane 03.13.26- 04.14.26		11.00	85,899.03
05/26/2026	07ACH052626	Pasco County Utilities	21320 Wilderness Lake Blvd 03.13.26- 04.14.26		2,066.24	83,832.79
05/26/2026	08ACH052626	Waste Connections Of Florida	Monthly Fee - 06.01.26- 06.30.26		1,051.63	82,781.16
05/28/2026	1428	Department of Health In Pasco County			850.00	81,931.16
05/28/2026	101204	Fitness Logic	Invoice: 130004 (Reference: Fitness Equipment Cleaning.)		125.00	81,806.16
05/28/2026	101205	MPLC	Invoice: 504477145 (Reference: Motion Picture Licensing.)		4,242.70	77,563.46
05/28/2026	101206	A Total Solution, Inc	Invoice: i10612 (Reference: Security Systems Service/Repairs.)		223.00	77,340.46
05/28/2026	01ACH052826	Duke Energy	Summary Account 03.27.26- 04.27.26		12,930.13	64,410.33
05/28/2026	02ACH052826	Duke Energy	7973 Citrus Blossom Dr- Herons Glen 04.03.26- 05.04.26		30.80	64,379.53
05/29/2026	101207	Grant Hemond & Associates	Invoice: 469531-1074 (Reference: Final payment- DJ/MC services and dancefloor lighting to enhanc...		763.00	63,616.53
05/31/2026			Interest	13.29		63,629.82
5/31/2026	End of Month			144,646.01	165,067.08	63,629.82

The Preserve at Wilderness Lake CDD
Check Register - Truist - FY2026

Date	Number	Name	Memo	Deposits	Payments	Balance
09/30/2025		Beginning of Year				86,374.34
10/01/2025			Deposit	13.67		86,388.01
10/02/2025			Deposit	4.23		86,392.24
10/03/2025			Deposit	249.41		86,641.65
10/04/2025			Deposit	282.63		86,924.28
10/05/2025			Deposit	82.67		87,006.95
10/06/2025			Deposit	423.80		87,430.75
10/06/2025			Deposit	2.13		87,432.88
10/07/2025			Deposit	2.62		87,435.50
10/08/2025			Deposit	10.26		87,445.76
10/09/2025			Deposit	11.72		87,457.48
10/10/2025			Deposit	10.39		87,467.87
10/11/2025			Deposit	388.85		87,856.72
10/12/2025			Deposit	96.19		87,952.91
10/13/2025			Deposit	50.53		88,003.44
10/14/2025			Deposit	33.97		88,037.41
10/15/2025			Deposit	1,109.10		89,146.51
10/15/2025			Deposit	28.13		89,174.64
10/16/2025			Deposit	14.00		89,188.64
10/17/2025			Deposit	16.29		89,204.93
10/18/2025			Deposit	376.40		89,581.33
10/19/2025			Deposit	21.02		89,602.35
10/20/2025			Deposit	17.11		89,619.46
10/21/2025			Deposit	12.36		89,631.82
10/22/2025			Deposit	11.91		89,643.73
10/23/2025			Deposit	246.70		89,890.43
10/23/2025			Deposit	13.85		89,904.28
10/24/2025			Deposit	74.07		89,978.35
10/25/2025			Deposit	104.90		90,083.25
10/26/2025			Deposit	145.95		90,229.20
10/28/2025			Deposit	384.30		90,613.50
10/28/2025			Deposit	4.23		90,617.73
10/29/2025			Deposit	8.17		90,625.90
10/30/2025			Deposit	149.81		90,775.71
10/31/2025			Interest	0.75		90,776.46
10/31/2025		End of Month		4,402.12	-	90,776.46
11/01/2025			Deposit	107.21		90,883.67
11/02/2025			Deposit	213.46		91,097.13
11/03/2025			Deposit	81.00		91,178.13
11/03/2025			Deposit	9.59		91,187.72
11/04/2025			Deposit	12.06		91,199.78
11/05/2025			Deposit	1.31		91,201.09
11/06/2025			Deposit	28.80		91,229.89
11/07/2025			Deposit	1.31		91,231.20
11/08/2025			Deposit	28.92		91,260.12
11/09/2025			Deposit	78.44		91,338.56
11/10/2025			Deposit	514.65		91,853.21
11/11/2025			Deposit	14.31		91,867.52
11/12/2025			Deposit	0.82		91,868.34
11/13/2025			Deposit	2.77		91,871.11
11/14/2025			Deposit	18.27		91,889.38
11/15/2025			Deposit	172.92		92,062.30
11/16/2025			Deposit	183.21		92,245.51
11/17/2025			Deposit	8.16		92,253.67
11/17/2025			Deposit	59.00		92,312.67
11/18/2025			Deposit	17.87		92,330.54
11/19/2025			Deposit	11.90		92,342.44
11/20/2025			Deposit	4.08		92,346.52
11/21/2025			Deposit	7.83		92,354.35
11/22/2025			Deposit	233.35		92,587.70
11/23/2025			Deposit	19.74		92,607.44
11/24/2025			Deposit	30.41		92,637.85
11/25/2025			Deposit	5.54		92,643.39
11/26/2025			Deposit	190.10		92,833.49
11/26/2025			Deposit	1.80		92,835.29
11/28/2025			Deposit	12.21		92,847.50
11/29/2025			Deposit	35.92		92,883.42
11/30/2025			Deposit	32.99		92,916.41
11/30/2025			Interest	0.76		92,917.17
11/30/2025		End of Month		2,140.71	-	92,917.17
12/01/2025			Deposit	211.00		93,128.17
12/01/2025			Deposit	6.85		93,135.02

Date	Number	Name	Memo	Deposits	Payments	Balance
12/02/2025			Deposit	20.64		93,155.66
12/03/2025			Deposit	18.39		93,174.05
12/04/2025			Deposit	15.13		93,189.18
12/05/2025			Deposit	2.62		93,191.80
12/06/2025			Deposit	4.57		93,196.37
12/07/2025			Deposit	219.67		93,416.04
12/08/2025			Deposit	577.35		93,993.39
12/08/2025			Deposit	11.23		94,004.62
12/09/2025			Deposit	30.11		94,034.73
12/10/2025			Deposit	44.20		94,078.93
12/11/2025			Deposit	11.66		94,090.59
12/12/2025			Deposit	5.73		94,096.32
12/13/2025			Deposit	80.77		94,177.09
12/14/2025			Deposit	46.30		94,223.39
12/15/2025			Deposit	408.50		94,631.89
12/15/2025			Deposit	94.70		94,726.59
12/16/2025			Deposit	43.02		94,769.61
12/17/2025			Deposit	177.64		94,947.25
12/18/2025			Deposit	12.36		94,959.61
12/19/2025			Deposit	142.46		95,102.07
12/20/2025			Deposit	128.28		95,230.35
12/21/2025			Deposit	157.61		95,387.96
12/22/2025			Deposit	338.50		95,726.46
12/22/2025			Deposit	9.77		95,736.23
12/23/2025			Deposit	9.29		95,745.52
12/24/2025			Deposit	4.90		95,750.42
12/26/2025			Deposit	28.50		95,778.92
12/27/2025			Deposit	132.84		95,911.76
12/28/2025			Deposit	22.10		95,933.86
12/29/2025			Deposit	371.20		96,305.06
12/29/2025			Deposit	12.72		96,317.78
12/30/2025			Deposit	1.31		96,319.09
12/31/2025			Interest	0.80		96,319.89
12/31/2025		End of Month		3,402.72	-	96,319.89
01/02/2026			Deposit	53.15		96,373.04
01/03/2026			Deposit	7.00		96,380.04
01/04/2026			Deposit	11.23		96,391.27
01/05/2026			Deposit	2.77		96,394.04
01/06/2026			Deposit	43.74		96,437.78
01/07/2026			Deposit	106.70		96,544.48
01/07/2026			Deposit	24.09		96,568.57
01/08/2026			Deposit	0.82		96,569.39
01/09/2026			Deposit	16.14		96,585.53
01/10/2026			Deposit	14.16		96,599.69
01/11/2026			Deposit	3.26		96,602.95
01/12/2026			Deposit	4.08		96,607.03
01/13/2026			Deposit	484.10		97,091.13
01/13/2026			Deposit	25.73		97,116.86
01/14/2026			Deposit	2.77		97,119.63
01/15/2026			Deposit	1.31		97,120.94
01/16/2026			Deposit	24.24		97,145.18
01/17/2026			Deposit	52.66		97,197.84
01/18/2026			Deposit	0.82		97,198.66
01/19/2026			Deposit	29.47		97,228.13
01/20/2026			Deposit	239.95		97,468.08
01/20/2026			Deposit	35.14		97,503.22
01/21/2026			Deposit	14.87		97,518.09
01/22/2026			Deposit	1.80		97,519.89
01/23/2026			Deposit	25.05		97,544.94
01/24/2026			Deposit	185.22		97,730.16
01/25/2026			Deposit	22.13		97,752.29
01/26/2026			Deposit	833.20		98,585.49
01/26/2026			Deposit	19.31		98,604.80
01/27/2026			Deposit	11.73		98,616.53
01/28/2026			Deposit	25.69		98,642.22
01/29/2026			Deposit	2.62		98,644.84
01/30/2026			Deposit	175.51		98,820.35
01/31/2026			Deposit	523.75		99,344.10
01/31/2026			Interest	0.83		99,344.93
1/31/2026		End of Month		3,025.04	-	99,344.93
02/02/2026			Deposit	143.45		99,488.38
02/02/2026			Deposit	12.69		99,501.07
02/03/2026			Deposit	212.55		99,713.62
02/04/2026			Deposit	4.08		99,717.70
02/05/2026			Deposit	5.69		99,723.39

Date	Number	Name	Memo	Deposits	Payments	Balance
02/06/2026			Deposit	55.65		99,779.04
02/07/2026			Deposit	244.69		100,023.73
02/08/2026			Deposit	172.28		100,196.01
02/09/2026			Deposit	471.10		100,667.11
02/09/2026			Deposit	4.23		100,671.34
02/10/2026			Deposit	3.26		100,674.60
02/11/2026			Deposit	8.46		100,683.06
02/12/2026			Deposit	26.70		100,709.76
02/13/2026			Deposit	16.47		100,726.23
02/14/2026			Deposit	11.12		100,737.35
02/15/2026			Deposit	176.02		100,913.37
02/16/2026			Deposit	13.70		100,927.07
02/17/2026			Deposit	39.52		100,966.59
02/18/2026			Deposit	7.00		100,973.59
02/19/2026			Deposit	213.95		101,187.54
02/19/2026			Deposit	18.05		101,205.59
02/20/2026			Deposit	21.97		101,227.56
02/21/2026			Deposit	258.96		101,486.52
02/22/2026			Deposit	85.78		101,572.30
02/23/2026			Deposit	158.75		101,731.05
02/23/2026			Deposit	15.65		101,746.70
02/24/2026			Deposit	23.44		101,770.14
02/25/2026			Deposit	159.66		101,929.80
02/26/2026			Deposit	32.25		101,962.05
02/26/2026			Deposit	2.77		101,964.82
02/27/2026			Deposit	151.82		102,116.64
02/27/2026			Interest	0.77		102,117.41
02/28/2026			Deposit	284.20		102,401.61
2/28/2025		End of Month		3,056.68	-	102,401.61
03/01/2026			Deposit	212.95		102,614.56
03/02/2026			Deposit	45.88		102,660.44
03/03/2026			Deposit	9.59		102,670.03
03/04/2026			Deposit	116.00		102,786.03
03/04/2026			Deposit	12.05		102,798.08
03/05/2026			Deposit	22.37		102,820.45
03/06/2026			Deposit	4.08		102,824.53
03/07/2026			Deposit	314.65		103,139.18
03/08/2026			Deposit	190.48		103,329.66
03/09/2026			Deposit	8.16		103,337.82
03/10/2026			Deposit	51.72		103,389.54
03/11/2026			Deposit	19.88		103,409.42
03/12/2026			Deposit	984.20		104,393.62
03/12/2026			Deposit	31.30		104,424.92
03/13/2026			Deposit	249.37		104,674.29
03/14/2026			Deposit	103.72		104,778.01
03/15/2026			Deposit	104.35		104,882.36
03/16/2026			Deposit	39.39		104,921.75
03/17/2026			Deposit	236.20		105,157.95
03/17/2026			Deposit	16.43		105,174.38
03/18/2026			Deposit	3.59		105,177.97
03/19/2026			Deposit	32.16		105,210.13
03/20/2026			Deposit	14.01		105,224.14
03/21/2026			Deposit	95.21		105,319.35
03/22/2026			Deposit	246.21		105,565.56
03/23/2026			Deposit	8.55		105,574.11
03/23/2026			Deposit	183.00		105,757.11
03/24/2026			Deposit	10.68		105,767.79
03/25/2026			Deposit	23.93		105,791.72
03/26/2026			Deposit	15.47		105,807.19
03/27/2026			Deposit	26.72		105,833.91
03/28/2026			Deposit	30.38		105,864.29
03/29/2026			Deposit	27.20		105,891.49
03/30/2026			Deposit	337.40		106,228.89
03/30/2026			Deposit	45.55		106,274.44
03/31/2026			Deposit	28.34		106,302.78
03/31/2026			Interest	0.89		106,303.67
3/31/2026		End of Month		3,902.06	-	106,303.67
04/01/2026			Deposit	16.45		106,320.12
04/02/2026			Deposit	43.48		106,363.60
04/03/2026			Deposit	34.97		106,398.57
04/04/2026			Deposit	358.16		106,756.73
04/06/2026			Deposit	356.40		107,113.13
04/06/2026			Deposit	40.85		107,153.98
04/07/2026			Deposit	5.63		107,159.61
04/08/2026			Deposit	57.32		107,216.93

Date	Number	Name	Memo	Deposits	Payments	Balance
04/09/2026			Deposit	12.00		107,228.93
04/10/2026			Deposit	6.36		107,235.29
04/11/2026			Deposit	176.88		107,412.17
04/12/2026			Deposit	239.04		107,651.21
04/13/2026			Deposit	474.60		108,125.81
04/13/2026			Deposit	18.42		108,144.23
04/14/2026			Deposit	216.66		108,360.89
04/15/2026			Deposit	10.26		108,371.15
04/16/2026			Deposit	33.19		108,404.34
04/17/2026			Deposit	26.05		108,430.39
04/18/2026			Deposit	90.26		108,520.65
04/19/2026			Deposit	181.71		108,702.36
04/20/2026			Deposit	182.00		108,884.36
04/20/2026			Deposit	11.96		108,896.32
04/21/2026			Deposit	23.28		108,919.60
04/22/2026			Deposit	8.89		108,928.49
04/23/2026			Deposit	24.57		108,953.06
04/24/2026			Deposit	192.92		109,145.98
04/25/2026			Deposit	365.32		109,511.30
04/26/2026			Deposit	32.12		109,543.42
04/27/2026			Deposit	15.96		109,559.38
04/28/2026			Deposit	325.30		109,884.68
04/28/2026			Deposit	34.49		109,919.17
04/29/2026			Deposit	17.26		109,936.43
04/30/2026			Deposit	105.71		110,042.14
04/30/2026			Interest	0.89		110,043.03
4/30/2026		End of Month		3,739.36	-	110,043.03
05/01/2026			Deposit	24.44		110,067.47
05/02/2026			Deposit	49.44		110,116.91
05/03/2026			Deposit	194.33		110,311.24
05/04/2026			Deposit	5.88		110,317.12
05/05/2026			Deposit	11.17		110,328.29
05/06/2026			Deposit	216.50		110,544.79
05/06/2026			Deposit	4.08		110,548.87
05/07/2026			Deposit	19.54		110,568.41
05/08/2026			Deposit	4.41		110,572.82
05/09/2026			Deposit	160.51		110,733.33
05/10/2026			Deposit	247.65		110,980.98
05/11/2026			Deposit	452.20		111,433.18
05/11/2026			Deposit	12.21		111,445.39
05/12/2026			Deposit	2.77		111,448.16
05/13/2026			Deposit	29.39		111,477.55
05/14/2026			Deposit	16.44		111,493.99
05/15/2026			Deposit	149.06		111,643.05
05/16/2026			Deposit	178.46		111,821.51
05/17/2026			Deposit	102.55		111,924.06
05/18/2026			Deposit	405.50		112,329.56
05/18/2026			Deposit	83.08		112,412.64
05/19/2026	162		Refund of Day Pass		50.63	112,362.01
05/19/2026			Deposit	15.45		112,377.46
05/20/2026			Deposit	212.40		112,589.86
05/21/2026			Deposit	25.57		112,615.43
05/22/2026			Deposit	49.65		112,665.08
05/23/2026			Deposit	241.92		112,907.00
05/24/2026			Deposit	214.60		113,121.60
05/25/2026			Deposit	27.55		113,149.15
05/26/2026			Deposit	10.45		113,159.60
05/27/2026			Deposit	14.48		113,174.08
05/28/2026			Deposit	321.70		113,495.78
05/28/2026			Deposit	13.18		113,508.96
05/28/2026			Deposit	4.23		113,513.19
05/29/2026			Deposit	27.86		113,541.05
05/30/2026			Deposit	331.08		113,872.13
05/31/2026			Deposit	173.33		114,045.46
05/31/2026			Interest	0.95		114,046.41
5/31/2026		End of Month		4,054.01	50.63	114,046.41

The Preserve at Wilderness Lake CDD
Reconciliation Summary
1101000 · BankUnited - Operating, Period Ending 05/31/2026

	<u>May 31, 26</u>	
Beginning Balance		98,893.18
Cleared Transactions		
Checks and Payments - 68 items	-172,816.08	
Deposits and Credits - 5 items	144,646.01	
Total Cleared Transactions	<u>-28,170.07</u>	
Cleared Balance		<u>70,723.11</u>
Uncleared Transactions		
Checks and Payments - 14 items	-7,093.29	
Total Uncleared Transactions	<u>-7,093.29</u>	
Register Balance as of 05/31/2026		<u>63,629.82</u>
New Transactions		
Deposits and Credits - 1 item	390,000.00	
Total New Transactions	<u>390,000.00</u>	
Ending Balance		<u>453,629.82</u>

The Preserve at Wilderness Lake CDD
Reconciliation Detail
1101000 · BankUnited - Operating, Period Ending 05/31/2026

Type	Date	Num	Name	Clr	Amount	Balance
Beginning Balance						98,893.18
Cleared Transactions						
Checks and Payments - 68 items						
Bill Pmt -Check	03/11/2026	101099	Brian Peters LLC	X	-6,000.00	-6,000.00
Bill Pmt -Check	04/09/2026	101137	Brletic Dvorak Inc	X	-210.00	-6,210.00
Bill Pmt -Check	04/15/2026	101144	Electro Sanitation S...	X	-2,695.68	-8,905.68
Bill Pmt -Check	04/21/2026	101147	GHS, LLC	X	-2,200.00	-11,105.68
Bill Pmt -Check	04/21/2026	101150	Romaner Graphics	X	-713.00	-11,818.68
Bill Pmt -Check	04/21/2026	101155	Rentalex of Pasco	X	-563.25	-12,381.93
Bill Pmt -Check	04/21/2026	101153	Inteligy Tampa Bay ...	X	-330.00	-12,711.93
Bill Pmt -Check	04/29/2026	1426	Leaders Casual Fur...	X	-796.97	-13,508.90
Bill Pmt -Check	05/04/2026	101161	RedTree Landscape...	X	-15,310.56	-28,819.46
Bill Pmt -Check	05/04/2026	02AC...	BANK UNITED VIS...	X	-3,881.14	-32,700.60
Bill Pmt -Check	05/04/2026	101157	Pasco Sheriff's Office	X	-2,200.00	-34,900.60
Bill Pmt -Check	05/04/2026	101164	Arrow Exterminators	X	-1,185.00	-36,085.60
Bill Pmt -Check	05/04/2026	101162	DCSI, Inc.	X	-670.00	-36,755.60
Bill Pmt -Check	05/04/2026	101159	Romaner Graphics	X	-650.00	-37,405.60
Bill Pmt -Check	05/04/2026	101156	A Total Solution, Inc	X	-600.00	-38,005.60
Bill Pmt -Check	05/04/2026	101165	Cooper Pools Inc.	X	-547.22	-38,552.82
Bill Pmt -Check	05/04/2026	101167	Palm Beach Securit...	X	-522.00	-39,074.82
Bill Pmt -Check	05/04/2026	01AC...	Frontier	X	-450.69	-39,525.51
Bill Pmt -Check	05/04/2026	101163	CDW Government L...	X	-301.50	-39,827.01
Bill Pmt -Check	05/04/2026	101158	McNatt Plumbing Co...	X	-185.00	-40,012.01
Bill Pmt -Check	05/04/2026	101160	Himes Electrical Ser...	X	-163.75	-40,175.76
Bill Pmt -Check	05/04/2026	101166	Fitness Logic	X	-125.00	-40,300.76
Bill Pmt -Check	05/06/2026	01AC...	Duke Energy	X	-1,424.27	-41,725.03
Bill Pmt -Check	05/07/2026	101168	FitRev Inc	X	-14,495.40	-56,220.43
Bill Pmt -Check	05/11/2026	101169	Vesta District Services	X	-40,915.28	-97,135.71
Bill Pmt -Check	05/11/2026	101170	Cooper Pools Inc.	X	-7,532.89	-104,668.60
Bill Pmt -Check	05/11/2026	101174	RedTree Landscape...	X	-2,100.00	-106,768.60
Bill Pmt -Check	05/11/2026	101176	Sunrise Propane	X	-679.16	-107,447.76
Bill Pmt -Check	05/11/2026	101175	DCSI, Inc.	X	-494.00	-107,941.76
Bill Pmt -Check	05/11/2026	101172	Palm Beach Securit...	X	-476.00	-108,417.76
Bill Pmt -Check	05/11/2026	101177	10-S Tennis Supply ...	X	-151.89	-108,569.65
Bill Pmt -Check	05/11/2026	101173	Himes Electrical Ser...	X	-140.00	-108,709.65
Bill Pmt -Check	05/11/2026	101171	McNatt's Cleaners	X	-60.80	-108,770.45
Bill Pmt -Check	05/12/2026	01AC...	Frontier	X	-125.98	-108,896.43
Bill Pmt -Check	05/13/2026	101179	Vesta District Services	X	-7,158.50	-116,054.93
Bill Pmt -Check	05/13/2026	101182	CDW Government L...	X	-1,621.59	-117,676.52
Bill Pmt -Check	05/13/2026	101178	Brletic Dvorak Inc	X	-945.00	-118,621.52
Bill Pmt -Check	05/13/2026	101181	RedTree Landscape...	X	-800.00	-119,421.52
Bill Pmt -Check	05/13/2026	101180	10-S Tennis Supply ...	X	-68.89	-119,490.41
Bill Pmt -Check	05/18/2026	101184	Cooper Pools Inc.	X	-9,397.92	-128,888.33
Bill Pmt -Check	05/18/2026	101186	GHS, LLC	X	-6,181.67	-135,070.00
Bill Pmt -Check	05/18/2026	101190	PSA Horticultural	X	-1,100.00	-136,170.00
Bill Pmt -Check	05/18/2026	101188	Straley Robin Vericker	X	-810.50	-136,980.50
Bill Pmt -Check	05/18/2026	101192	RedTree Landscape...	X	-498.98	-137,479.48
Bill Pmt -Check	05/18/2026	101189	Cool Coast Heating ...	X	-488.00	-137,967.48
Bill Pmt -Check	05/18/2026	101185	Fitness Logic	X	-350.98	-138,318.46
Bill Pmt -Check	05/18/2026	101194	John Staples	X	-200.00	-138,518.46
Bill Pmt -Check	05/18/2026	101195	A Total Solution, Inc	X	-74.00	-138,592.46
Bill Pmt -Check	05/19/2026	01AC...	Frontier	X	-145.49	-138,737.95
Bill Pmt -Check	05/20/2026	EFT05...	FL Dept. of Rev.	X	-262.21	-139,000.16
Bill Pmt -Check	05/21/2026	101197	RedTree Landscape...	X	-9,744.00	-148,744.16
Bill Pmt -Check	05/21/2026	101198	State Wildlife Trapp...	X	-1,200.00	-149,944.16
Bill Pmt -Check	05/21/2026	101200	Cooper Pools Inc.	X	-420.00	-150,364.16
Bill Pmt -Check	05/21/2026	101202	10-S Tennis Supply ...	X	-306.98	-150,671.14
Bill Pmt -Check	05/21/2026	101201	Ready Refresh	X	-47.98	-150,719.12
Bill Pmt -Check	05/22/2026	101203	ProPet Distributors	X	-1,160.16	-151,879.28
Bill Pmt -Check	05/26/2026	07AC...	Pasco County Utilities	X	-2,066.24	-153,945.52
Bill Pmt -Check	05/26/2026	08AC...	Waste Connections ...	X	-1,051.63	-154,997.15
Bill Pmt -Check	05/26/2026	01AC...	Pasco County Utilities	X	-333.12	-155,330.27
Bill Pmt -Check	05/26/2026	02AC...	Pasco County Utilities	X	-89.76	-155,420.03
Bill Pmt -Check	05/26/2026	05AC...	Pasco County Utilities	X	-34.42	-155,454.45
Bill Pmt -Check	05/26/2026	04AC...	Pasco County Utilities	X	-11.00	-155,465.45
Bill Pmt -Check	05/26/2026	06AC...	Pasco County Utilities	X	-11.00	-155,476.45
Bill Pmt -Check	05/26/2026	03AC...	Pasco County Utilities	X	-11.00	-155,487.45
Bill Pmt -Check	05/28/2026	01AC...	Duke Energy	X	-12,930.13	-168,417.58

The Preserve at Wilderness Lake CDD
Reconciliation Detail
1101000 · BankUnited - Operating, Period Ending 05/31/2026

Type	Date	Num	Name	Clr	Amount	Balance
Bill Pmt -Check	05/28/2026	101205	MPLC	X	-4,242.70	-172,660.28
Bill Pmt -Check	05/28/2026	101204	Fitness Logic	X	-125.00	-172,785.28
Bill Pmt -Check	05/28/2026	02AC...	Duke Energy	X	-30.80	-172,816.08
Total Checks and Payments					-172,816.08	-172,816.08
Deposits and Credits - 5 items						
Transfer	05/04/2026			X	140,000.00	140,000.00
Bill Pmt -Check	05/06/2026		Duke Energy	X	0.00	140,000.00
Deposit	05/12/2026			X	4,632.72	144,632.72
Bill Pmt -Check	05/28/2026	EFT04...	Duke Energy	X	0.00	144,632.72
Deposit	05/31/2026			X	13.29	144,646.01
Total Deposits and Credits					144,646.01	144,646.01
Total Cleared Transactions					-28,170.07	-28,170.07
Cleared Balance					-28,170.07	70,723.11
Uncleared Transactions						
Checks and Payments - 14 items						
Bill Pmt -Check	12/06/2024	1270	Cooper Pools Inc.		-150.00	-150.00
Bill Pmt -Check	09/26/2025	1360	Animal & Exotic Me...		-467.34	-617.34
Bill Pmt -Check	12/09/2025	1386	Heather Hepner		-200.00	-817.34
Bill Pmt -Check	01/14/2026	1397	Himes Electrical Ser...		-516.05	-1,333.39
Bill Pmt -Check	05/18/2026	101193	Inteligy Tampa Bay ...		-330.00	-1,663.39
Bill Pmt -Check	05/18/2026	101187	Holly Ruhlig		-200.00	-1,863.39
Bill Pmt -Check	05/18/2026	101183	Agnieszka Fisher		-200.00	-2,063.39
Bill Pmt -Check	05/18/2026	101191	Virginia B. Edwards		-200.00	-2,263.39
Bill Pmt -Check	05/18/2026	101196	Heather Hepner		-200.00	-2,463.39
Bill Pmt -Check	05/21/2026	101199	Electro Sanitation S...		-2,499.81	-4,963.20
Bill Pmt -Check	05/22/2026	1427	Ellen L Dobson - Pet...		-294.09	-5,257.29
Bill Pmt -Check	05/28/2026	1428	Department of Healt...		-850.00	-6,107.29
Bill Pmt -Check	05/28/2026	101206	A Total Solution, Inc		-223.00	-6,330.29
Bill Pmt -Check	05/29/2026	101207	Grant Hemond & As...		-763.00	-7,093.29
Total Checks and Payments					-7,093.29	-7,093.29
Total Uncleared Transactions					-7,093.29	-7,093.29
Register Balance as of 05/31/2026					-35,263.36	63,629.82
New Transactions						
Deposits and Credits - 1 item						
Transfer	06/03/2026				390,000.00	390,000.00
Total Deposits and Credits					390,000.00	390,000.00
Total New Transactions					390,000.00	390,000.00
Ending Balance					354,736.64	453,629.82

P.O. Box 521599 Miami, FL 33152-1599

>000968 6909580 0001 008229 20Z
 PRESERVE AT WILDERNESS LAKE COMMUNITY
 DEVELOPMENT DISTRICT
 250 INTERNATIONAL PKWY STE 208
 LAKE MARY FL 32765

Statement Date: May 31, 2026

Account Number: *****5814

Customer Service Information

 Client Care: 877-779-BANK (2265)

 Web Site: www.bankunited.com

 Bank Address: BankUnited
 P.O. Box 521599
 Miami, FL 33152-1599



Customer Message Center

New Client Care Center Hours: Please refer to the end of this statement for updates to our Client Care Center operating hours.

PUBLIC FUNDS INTEREST CHECKING Account ***5814**

Account Summary

Statement Balance as of 04/30/2026		\$98,893.18
Plus	2 Deposits and Other Credits	\$144,632.72
Less	68 Withdrawals, Checks, and Other Debits	\$172,816.08
Less	Service Charge	\$0.00
Plus	Interest Paid	\$13.29
Statement Balance as of 05/31/2026		\$70,723.11

Interest Summary

Beginning Interest Rate	0.10%
Interest Paid this Statement Period	\$13.29
Interest Paid Year to Date	\$133.15

Activity By Date

Date	Description	Withdrawals	Deposits	Balance
05/04/2026	WEB TFR FR 009856113786		\$140,000.00	\$238,893.18
	101256000766			
	WEB RF#101256000766			

Statement Date: May 31, 2026

Account Number: *****5814

Activity By Date

<i>Date</i>	<i>Description</i>	<i>Withdrawals</i>	<i>Deposits</i>	<i>Balance</i>
05/04/2026	CHECK #101144	\$2,695.68		\$236,197.50
05/04/2026	CARDMEMBER SERV WEB PYMT *****8836 PAYABLE,ACCOUNTS 30	\$3,881.14		\$232,316.36
05/04/2026	FRONTIER COMMUNI BILL PAY 10536677321 PRESERVEAT WILDERNESS	\$450.69		\$231,865.67
05/05/2026	CHECK #101155	\$563.25		\$231,302.42
05/05/2026	AVIDPAY SERVICE AVIDPAY CK101166 The Preserve at Wilder	\$125.00		\$231,177.42
05/05/2026	AVIDPAY SERVICE AVIDPAY CK101158 The Preserve at Wilder	\$185.00		\$230,992.42
05/05/2026	AVIDPAY SERVICE AVIDPAY CK101164 The Preserve at Wilder	\$1,185.00		\$229,807.42
05/05/2026	AVIDPAY SERVICE AVIDPAY CK101160 The Preserve at Wilder	\$163.75		\$229,643.67
05/05/2026	AVIDPAY SERVICE AVIDPAY CK101162 The Preserve at Wilder	\$670.00		\$228,973.67
05/05/2026	AVIDPAY SERVICE AVIDPAY CK101163 The Preserve at Wilder	\$301.50		\$228,672.17
05/05/2026	AVIDPAY SERVICE AVIDPAY CK101167 The Preserve at Wilder	\$522.00		\$228,150.17
05/05/2026	AVIDPAY SERVICE AVIDPAY CK101165 The Preserve at Wilder	\$547.22		\$227,602.95
05/06/2026	DUKEENERGY BILL PAY 930000013787 THE PRESERVE WILDERNES	\$1,424.27		\$226,178.68

Statement Date: May 31, 2026
Account Number: ***5814**

Activity By Date

<i>Date</i>	<i>Description</i>	<i>Withdrawals</i>	<i>Deposits</i>	<i>Balance</i>
05/07/2026	CHECK #1426	\$796.97		\$225,381.71
05/08/2026	CHECK #101153	\$330.00		\$225,051.71
05/11/2026	CHECK #101150	\$713.00		\$224,338.71
05/12/2026	PASCOTAX TAX ACC 00000000035378 THE PRESERVE AT WILDER		\$4,632.72	\$228,971.43
05/12/2026	CHECK #101147	\$2,200.00		\$226,771.43
05/12/2026	CHECK #101156	\$600.00		\$226,171.43
05/12/2026	CHECK #101161	\$15,310.56		\$210,860.87
05/12/2026	FRONTIER COMMUNI BILL PAY 10562239521 PRESERVEATWILDERNESSLA	\$125.98		\$210,734.89
05/12/2026	AVIDPAY SERVICE AVIDPAY CK101171 The Preserve at Wilder	\$60.80		\$210,674.09
05/12/2026	AVIDPAY SERVICE AVIDPAY CK101177 The Preserve at Wilder	\$151.89		\$210,522.20
05/12/2026	AVIDPAY SERVICE AVIDPAY CK101173 The Preserve at Wilder	\$140.00		\$210,382.20
05/12/2026	AVIDPAY SERVICE AVIDPAY CK101175 The Preserve at Wilder	\$494.00		\$209,888.20
05/12/2026	AVIDPAY SERVICE AVIDPAY CK101170 The Preserve at Wilder	\$7,532.89		\$202,355.31
05/12/2026	AVIDPAY SERVICE AVIDPAY CK101172 The Preserve at Wilder	\$476.00		\$201,879.31
05/14/2026	AVIDPAY SERVICE AVIDPAY CK101182 The Preserve at Wilder	\$1,621.59		\$200,257.72
05/14/2026	AVIDPAY SERVICE AVIDPAY CK101180	\$68.89		\$200,188.83

Statement Date: May 31, 2026

Account Number: *****5814

Activity By Date

<i>Date</i>	<i>Description</i>	<i>Withdrawals</i>	<i>Deposits</i>	<i>Balance</i>
	The Preserve at Wilder			
05/18/2026	CHECK #101137	\$210.00		\$199,978.83
05/18/2026	CHECK #101157	\$2,200.00		\$197,778.83
05/18/2026	CHECK #101159	\$650.00		\$197,128.83
05/19/2026	CHECK #101169	\$40,915.28		\$156,213.55
05/19/2026	CHECK #101174	\$2,100.00		\$154,113.55
05/19/2026	CHECK #101179	\$7,158.50		\$146,955.05
05/19/2026	FRONTIER COMMUNI BILL PAY 10578896761 PRESERVEAT WILDERNESS	\$145.49		\$146,809.56
05/19/2026	AVIDPAY SERVICE AVIDPAY CK101189 The Preserve at Wilder	\$488.00		\$146,321.56
05/19/2026	AVIDPAY SERVICE AVIDPAY CK101185 The Preserve at Wilder	\$350.98		\$145,970.58
05/19/2026	AVIDPAY SERVICE AVIDPAY CK101184 The Preserve at Wilder	\$9,397.92		\$136,572.66
05/20/2026	CHECK #101099	\$6,000.00		\$130,572.66
05/20/2026	FLA DEPT REVENUE C01 277351122 Preserve at Wilderness	\$262.21		\$130,310.45
05/21/2026	CHECK #101168	\$14,495.40		\$115,815.05
05/21/2026	CHECK #101176	\$679.16		\$115,135.89
05/22/2026	AVIDPAY SERVICE AVIDPAY CK101200 The Preserve at Wilder	\$420.00		\$114,715.89
05/22/2026	AVIDPAY SERVICE AVIDPAY CK101202 The Preserve at Wilder	\$306.98		\$114,408.91
05/22/2026	AVIDPAY SERVICE AVIDPAY CK101201 The Preserve at Wilder	\$47.98		\$114,360.93
05/26/2026	WASTE CONNECTION WEB_PAY	\$1,051.63		\$113,309.30

Statement Date: May 31, 2026
Account Number: ***5814**

Activity By Date

<i>Date</i>	<i>Description</i>	<i>Withdrawals</i>	<i>Deposits</i>	<i>Balance</i>
	16337606052126 PRESERVE AT WILDERNESS			
05/26/2026	CHECK #101181	\$800.00		\$112,509.30
05/26/2026	PASCOBCCUTENT UTILITYPMT PRESERVE AT WILDERNESS	\$333.12		\$112,176.18
05/26/2026	PASCOBCCUTENT UTILITYPMT PRESERVE AT WILDERNESS	\$34.42		\$112,141.76
05/26/2026	PASCOBCCUTENT UTILITYPMT PRESERVE AT WILDERNESS	\$2,066.24		\$110,075.52
05/26/2026	PASCOBCCUTENT UTILITYPMT PRESERVE AT WILDERNESS	\$11.00		\$110,064.52
05/26/2026	PASCOBCCUTENT UTILITYPMT PRESERVE AT WILDERNESS	\$89.76		\$109,974.76
05/26/2026	PASCOBCCUTENT UTILITYPMT PRESERVE AT WILDERNESS	\$11.00		\$109,963.76
05/26/2026	PASCOBCCUTENT UTILITYPMT PRESERVE AT WILDERNESS	\$11.00		\$109,952.76
05/26/2026	AVIDPAY SERVICE AVIDPAY CK101203 The Preserve at Wilder	\$1,160.16		\$108,792.60
05/27/2026	CHECK #101188	\$810.50		\$107,982.10
05/27/2026	CHECK #101190	\$1,100.00		\$106,882.10
05/27/2026	CHECK #101192	\$498.98		\$106,383.12
05/27/2026	CHECK #101194	\$200.00		\$106,183.12
05/28/2026	DUKEENERGY BILL PAY 910087464930 THE PRESERVE AT WILDER	\$30.80		\$106,152.32
05/28/2026	DUKEENERGY BILL PAY 930000013381 THE PRESERVE AT WILDER	\$12,930.13		\$93,222.19
05/28/2026	CHECK #101178	\$945.00		\$92,277.19
05/28/2026	CHECK #101186	\$6,181.67		\$86,095.52
05/28/2026	CHECK #101197	\$9,744.00		\$76,351.52
05/29/2026	CHECK #101195	\$74.00		\$76,277.52
05/29/2026	CHECK #101198	\$1,200.00		\$75,077.52

Statement Date: May 31, 2026

Account Number: *****5814

Activity By Date

Date	Description	Withdrawals	Deposits	Balance
05/29/2026	AVIDPAY SERVICE AVIDPAY CK101204 The Preserve at Wilder	\$125.00		\$74,952.52
05/29/2026	AVIDPAY SERVICE AVIDPAY CK101205 The Preserve at Wilder	\$4,242.70		\$70,709.82
05/29/2026	Interest Paid		\$13.29	\$70,723.11

Check Transactions

Check #	Date	Amount	Check #	Date	Amount	Check #	Date	Amount
1426	05/07	\$796.97	101157	05/18	\$2,200.00	101181*	05/26	\$800.00
101099*	05/20	\$6,000.00	101159*	05/18	\$650.00	101186*	05/28	\$6,181.67
101137*	05/18	\$210.00	101161*	05/12	\$15,310.56	101188*	05/27	\$810.50
101144*	05/04	\$2,695.68	101168*	05/21	\$14,495.40	101190*	05/27	\$1,100.00
101147*	05/12	\$2,200.00	101169	05/19	\$40,915.28	101192*	05/27	\$498.98
101150*	05/11	\$713.00	101174*	05/19	\$2,100.00	101194*	05/27	\$200.00
101153*	05/08	\$330.00	101176*	05/21	\$679.16	101195	05/29	\$74.00
101155*	05/05	\$563.25	101178*	05/28	\$945.00	101197*	05/28	\$9,744.00
101156	05/12	\$600.00	101179	05/19	\$7,158.50	101198	05/29	\$1,200.00

Items denoted with an "*" indicate processed checks out of sequence.

Rates by Date

Date	Rate
05/01	0.10%

Balances by Date

Date	Balance	Date	Balance	Date	Balance	Date	Balance
04/30	\$98,893.18	05/08	\$225,051.71	05/19	\$136,572.66	05/27	\$106,183.12
05/04	\$231,865.67	05/11	\$224,338.71	05/20	\$130,310.45	05/28	\$76,351.52
05/05	\$227,602.95	05/12	\$201,879.31	05/21	\$115,135.89	05/29	\$70,723.11
05/06	\$226,178.68	05/14	\$200,188.83	05/22	\$114,360.93		
05/07	\$225,381.71	05/18	\$197,128.83	05/26	\$108,792.60		

Statement Date: May 31, 2026

Account Number: *****5814

Other Balances

Minimum Balance this Statement Period

\$70,723.11



Effective Monday, March 2, 2026, the Client Care Center hours will be:

- Monday–Friday: 8:00 AM–7:00 PM ET
- Saturday: 9:00 AM–12:00 PM ET

These updated hours provide better coverage during peak times and faster assistance. You can also manage everyday banking anytime through Online and Mobile Banking providing self-service access outside of call center hours. We appreciate the opportunity to serve you and are committed to delivering an exceptional client experience.

Statement Date: May 31, 2026

Account Number: *****5814

If your account does not balance please check the following carefully:

Have you entered the amount of each check in your checkbook register?

Are the amounts of your deposits and other additions entered in your checkbook register the same as those on this statement?

Have you checked all additions and subtractions in your checkbook register?

Have you carried the correct balance forward when starting a new page in your checkbook register?

**IN CASE OF QUESTIONS OR ERRORS ABOUT YOUR STATEMENT:
PLEASE CALL (TOLL FREE) 1-877-779-BANK (2265) OR WRITE US AT:**

BankUnited Operations / EFT Error
7815 NW 148th ST, Miami Lakes, FL 33016

For Consumer Customers Only

Please contact us if you think your statement is wrong or if you need additional information about a transaction. We must hear from you no later than 60 days after we sent you the FIRST statement on which the error or problem appeared.

1. Tell us your name and account number.
2. Describe the error or the transfer you are unsure about and explain as clearly as you can why you believe there is an error or why you need further information.
3. Tell us the dollar amount of the suspected error.

You may be required to put your request in writing. We will investigate your complaint and will correct any error promptly.

For Electronic Funds Transfers, if we take more than 10 business days to investigate and correct the error, (20 business days if you are a new customer for electronic funds transfers occurring during the first 30 days after the first deposit is made to your account), we will recredit your consumer account for the amount you think is in error (plus interest if your account earns interest), so that you will have the use of the money during the time it takes us to complete our investigation.

For Substitute Checks, if we take more than 10 business days to investigate and correct the error, we will recredit your consumer account for the amount of loss up to the lesser of \$2,500.00 (plus interest if your account earns interest) or the amount of the substitute check. If your account is new (30 days from the date your account was established), has been subject to repeated overdrafts, or we believe the claim is fraudulent, we may delay the availability of recredited funds until we determine the claim is valid or until the 45th day after the claim was submitted.



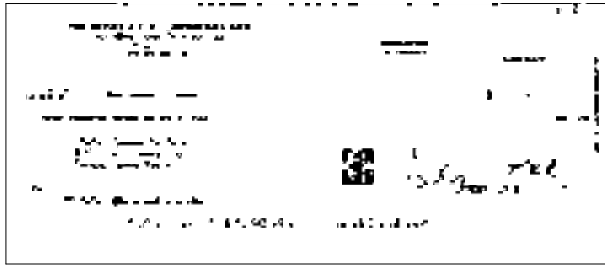

#1426 05/07/2026 \$796.97

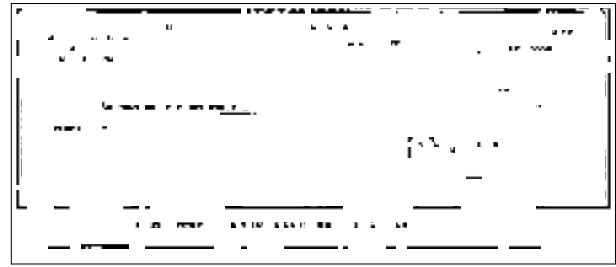

#101099 05/20/2026 \$6,000.00

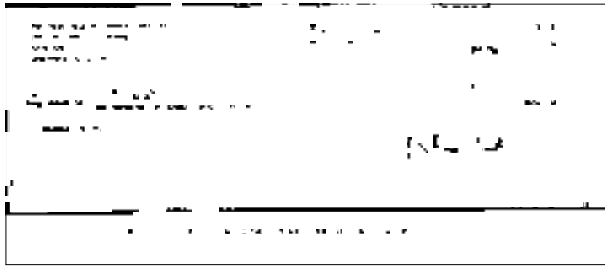

#101137 05/18/2026 \$210.00

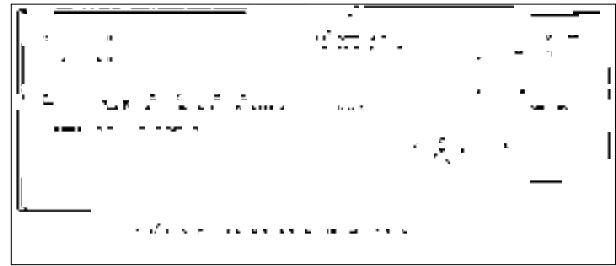

#101144 05/04/2026 \$2,695.68

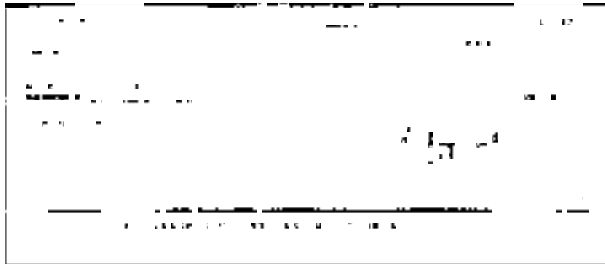

#101147 05/12/2026 \$2,200.00

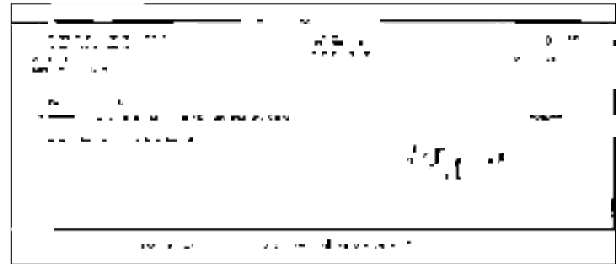

#101150 05/11/2026 \$713.00



#101153 05/08/2026 \$330.00

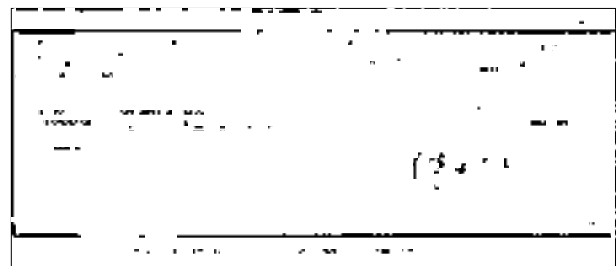

#101155 05/05/2026 \$563.25



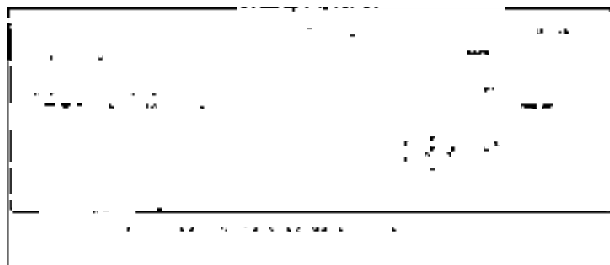

#101156 05/12/2026 \$600.00

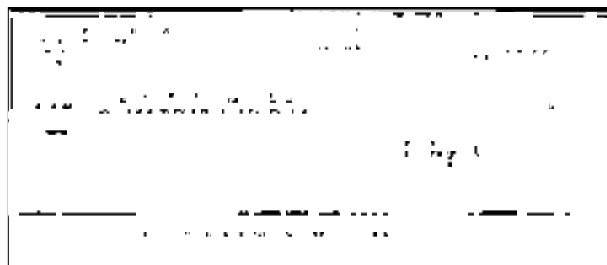

#101157 05/18/2026 \$2,200.00

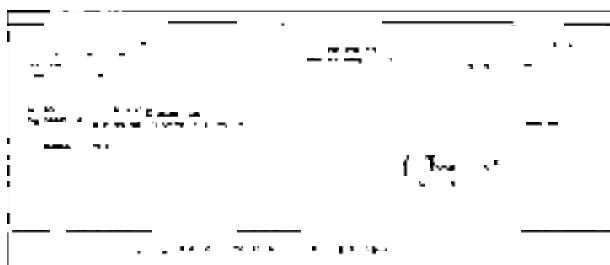

#101159 05/18/2026 \$650.00

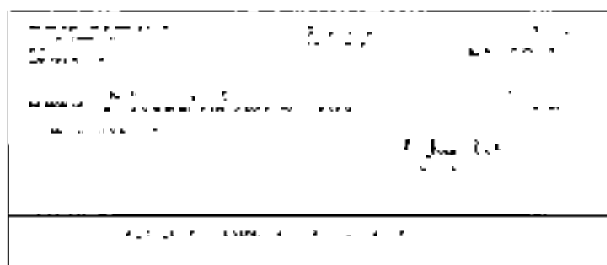

#101161 05/12/2026 \$15,310.56

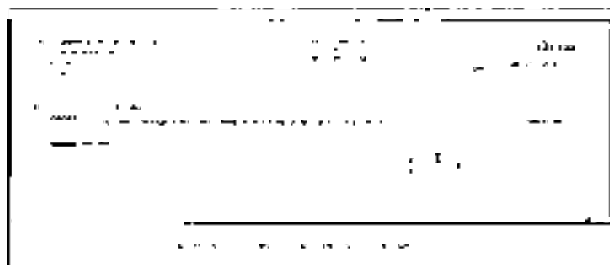

#101168 05/21/2026 \$14,495.40

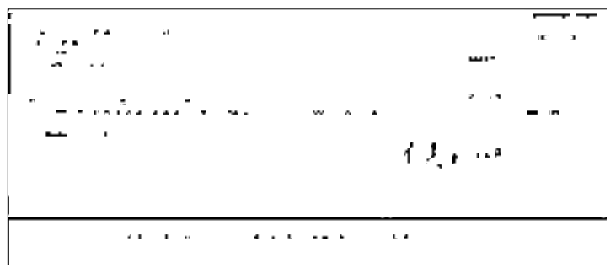

#101169 05/19/2026 \$40,915.28



#101174 05/19/2026 \$2,100.00

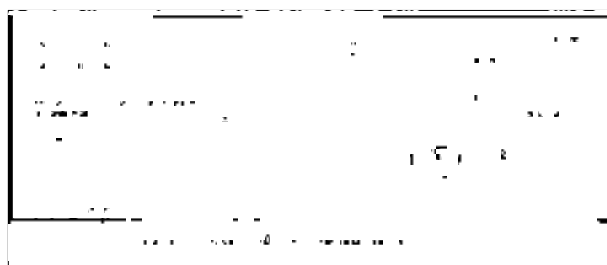

#101176 05/21/2026 \$679.16

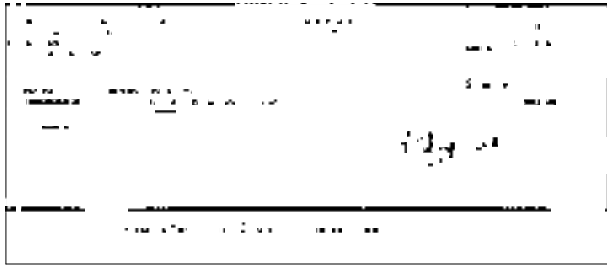

#101178 05/28/2026 \$945.00

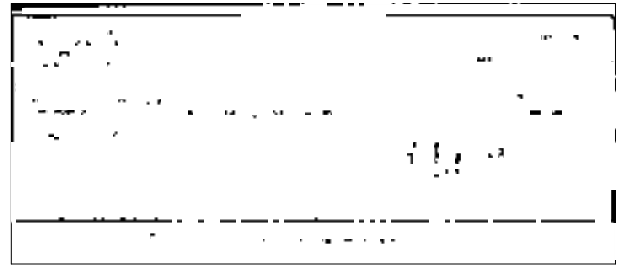

#101179 05/19/2026 \$7,158.50

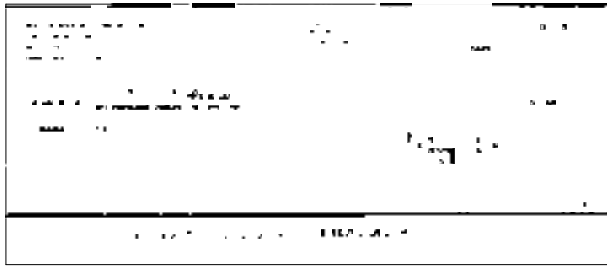

#101181 05/26/2026 \$800.00

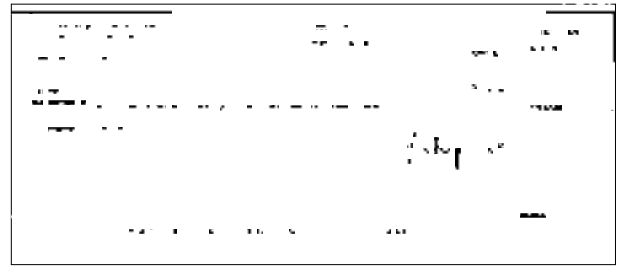

#101186 05/28/2026 \$6,181.67

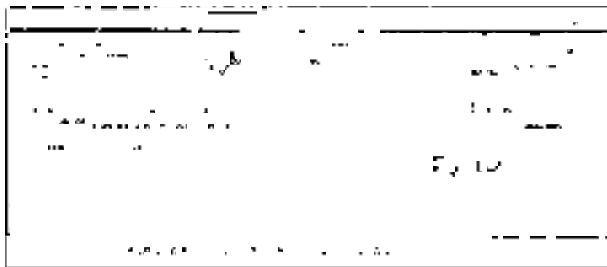

#101188 05/27/2026 \$810.50

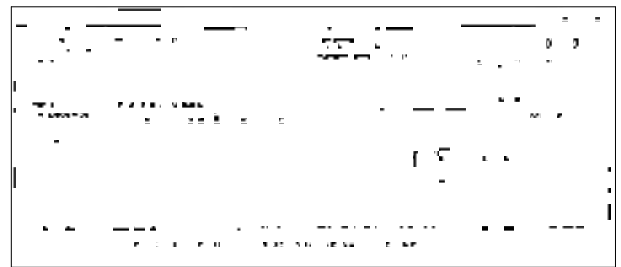

#101190 05/27/2026 \$1,100.00

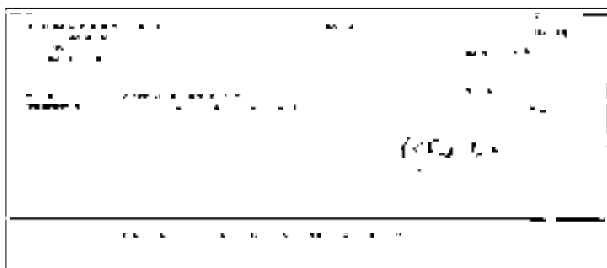

#101192 05/27/2026 \$498.98



#101194 05/27/2026 \$200.00

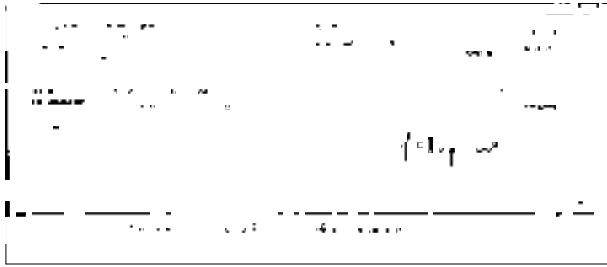

#101195 05/29/2026 \$74.00

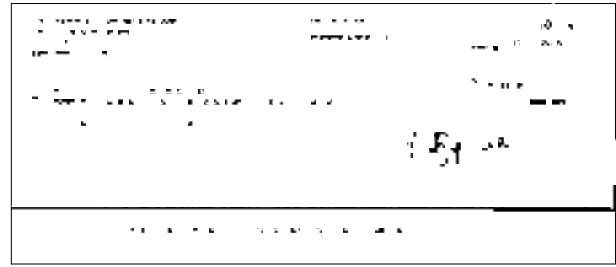

#101197 05/28/2026 \$9,744.00

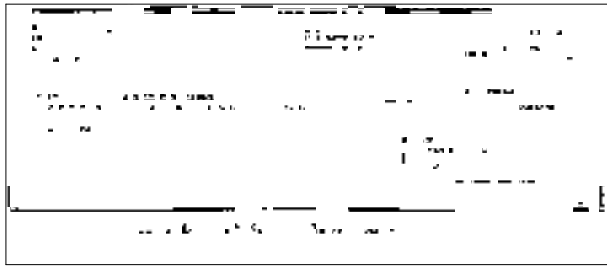

#101198 05/29/2026 \$1,200.00

The Preserve at Wilderness Lake CDD
Reconciliation Summary
1101002 · Truist - New Operating, Period Ending 05/31/2026

	<u>May 31, 26</u>
Beginning Balance	109,937.32
Cleared Transactions	
Checks and Payments - 1 item	-50.63
Deposits and Credits - 34 items	<u>3,623.22</u>
Total Cleared Transactions	<u>3,572.59</u>
Cleared Balance	<u>113,509.91</u>
Uncleared Transactions	
Deposits and Credits - 4 items	<u>536.50</u>
Total Uncleared Transactions	<u>536.50</u>
Register Balance as of 05/31/2026	<u>114,046.41</u>
Ending Balance	114,046.41

The Preserve at Wilderness Lake CDD
Reconciliation Detail
1101002 · Truist - New Operating, Period Ending 05/31/2026

Type	Date	Num	Name	Clr	Amount	Balance
Beginning Balance						109,937.32
Cleared Transactions						
Checks and Payments - 1 item						
General Journal	05/19/2026	162		X	-50.63	-50.63
Total Checks and Payments					-50.63	-50.63
Deposits and Credits - 34 items						
Deposit	04/30/2026			X	105.71	105.71
Deposit	05/01/2026			X	24.44	130.15
Deposit	05/02/2026			X	49.44	179.59
Deposit	05/03/2026			X	194.33	373.92
Deposit	05/04/2026			X	5.88	379.80
Deposit	05/05/2026			X	11.17	390.97
Deposit	05/06/2026			X	4.08	395.05
Deposit	05/06/2026			X	216.50	611.55
Deposit	05/07/2026			X	19.54	631.09
Deposit	05/08/2026			X	4.41	635.50
Deposit	05/09/2026			X	160.51	796.01
Deposit	05/10/2026			X	247.65	1,043.66
Deposit	05/11/2026			X	12.21	1,055.87
Deposit	05/11/2026			X	452.20	1,508.07
Deposit	05/12/2026			X	2.77	1,510.84
Deposit	05/13/2026			X	29.39	1,540.23
Deposit	05/14/2026			X	16.44	1,556.67
Deposit	05/15/2026			X	149.06	1,705.73
Deposit	05/16/2026			X	178.46	1,884.19
Deposit	05/17/2026			X	102.55	1,986.74
Deposit	05/18/2026			X	83.08	2,069.82
Deposit	05/18/2026			X	405.50	2,475.32
Deposit	05/19/2026			X	15.45	2,490.77
Deposit	05/20/2026			X	212.40	2,703.17
Deposit	05/21/2026			X	25.57	2,728.74
Deposit	05/22/2026			X	49.65	2,778.39
Deposit	05/23/2026			X	241.92	3,020.31
Deposit	05/24/2026			X	214.60	3,234.91
Deposit	05/25/2026			X	27.55	3,262.46
Deposit	05/26/2026			X	10.45	3,272.91
Deposit	05/27/2026			X	14.48	3,287.39
Deposit	05/28/2026			X	13.18	3,300.57
Deposit	05/28/2026			X	321.70	3,622.27
Deposit	05/31/2026			X	0.95	3,623.22
Total Deposits and Credits					3,623.22	3,623.22
Total Cleared Transactions					3,572.59	3,572.59
Cleared Balance					3,572.59	113,509.91
Uncleared Transactions						
Deposits and Credits - 4 items						
Deposit	05/28/2026				4.23	4.23
Deposit	05/29/2026				27.86	32.09
Deposit	05/30/2026				331.08	363.17
Deposit	05/31/2026				173.33	536.50
Total Deposits and Credits					536.50	536.50
Total Uncleared Transactions					536.50	536.50
Register Balance as of 05/31/2026					4,109.09	114,046.41
Ending Balance					4,109.09	114,046.41



859-01-01-00 10509 0 C 001 30 S 66 002
 THE PRESERVE AT WILDERNESS LAKE
 COMMUNITY DEVELOPMENT DISTRICT
 C/O VESTA PROPERT SERVICES INC
 245 RIVERSIDE AVE STE 300
 JACKSONVILLE FL 32202-4929

Your account statement

For 05/29/2026

Contact us



Truist.com



(844) 4TRUIST or
 (844) 487-8478

■ ASSOC SVCS INTEREST CHECKING 1100023898630

Account summary

Your previous balance as of 04/30/2026	\$109,937.32
Checks	- 0.00
Other withdrawals, debits and service charges	- 35.18
Deposits, credits and interest	+ 3,607.77
Your new balance as of 05/29/2026	= \$113,509.91

Interest summary

Interest paid this statement period	\$0.95
2026 interest paid year-to-date	\$4.33
Interest rate	0.01%
Annual percentage yield (APY) earned	0.01%

Other withdrawals, debits and service charges

DATE	DESCRIPTION	AMOUNT(\$)
05/20	ACH CORP DEBIT SQ260520 Square Inc Johanna Skye Lee CUSTOMER ID T3XE1229V5S704T	35.18

Total other withdrawals, debits and service charges = \$35.18

Deposits, credits and interest

DATE	DESCRIPTION	AMOUNT(\$)
05/01	SQ260501 Square Inc Johanna Skye Lee CUSTOMER ID T36J3RBEX21XDYK	105.71
05/04	SQ260504 Square Inc Johanna Skye Lee CUSTOMER ID T3EMK4K9EQ8MV4M	19.54
05/04	DEPOSIT	216.50
05/04	SQ260504 Square Inc Johanna Skye Lee CUSTOMER ID T3HPBPHBGX2SQRR	248.67
05/05	SQ260505 Square Inc Johanna Skye Lee CUSTOMER ID T3G7DRQQR4V100A	5.88
05/06	SQ260506 Square Inc Johanna Skye Lee CUSTOMER ID T34DZJRE0W04Q04	11.08
05/07	SQ260507 Square Inc Johanna Skye Lee CUSTOMER ID T3SER7NMVQDRSJA	4.17
05/08	SQ260508 Square Inc Johanna Skye Lee CUSTOMER ID T3JEG2F7E2CDHM1	19.54
05/11	SQ260511 Square Inc Johanna Skye Lee CUSTOMER ID T3CZANDB239NB4J	4.41
05/11	SQ260511 Square Inc Johanna Skye Lee CUSTOMER ID T3R10520CM0T9WF	403.93
05/11	DEPOSIT	452.20
05/12	SQ260512 Square Inc Johanna Skye Lee CUSTOMER ID T3CPVDZ9VQ6B86D	16.44
05/13	SQ260513 Square Inc Johanna Skye Lee CUSTOMER ID T3E7TVGSZ22B404	2.77
05/14	SQ260514 Square Inc Johanna Skye Lee CUSTOMER ID T3JVRWR68H2A802	18.49
05/15	SQ260515 Square Inc Johanna Skye Lee CUSTOMER ID T30GFHPE2FE3WD5	23.11
05/18	SQ260518 Square Inc Johanna Skye Lee CUSTOMER ID T3QSMN143T52446	153.29
05/18	SQ260518 Square Inc Johanna Skye Lee CUSTOMER ID T37K59MZ0C68A30	272.55
05/18	DEPOSIT	405.50
05/19	SQ260519 Square Inc Johanna Skye Lee CUSTOMER ID T3CKJSZ0B16C1M0	91.54
05/21	SQ260521 Square Inc Johanna Skye Lee CUSTOMER ID T3ATQHW8WS57N53	212.40
05/22	SQ260522 Square Inc Johanna Skye Lee CUSTOMER ID T3NJ3EBFCMPF201	21.34
05/26	SQ260526 Square Inc Johanna Skye Lee CUSTOMER ID T3XAFSWG5Y4F94T	27.55
05/26	SQ260526 Square Inc Johanna Skye Lee CUSTOMER ID T3AEVZNGDV92NA2	50.38

continued

■ ASSOC SVCS INTEREST CHECKING 1100023898630 (continued)

DATE	DESCRIPTION	AMOUNT(\$)
05/26	DEPOSIT	321.70
05/26	SQ260526 Square Inc Johanna Skye Lee CUSTOMER ID T3XDAY9MFQQEN38	460.02
05/27	SQ260527 Square Inc Johanna Skye Lee CUSTOMER ID T3060P7DH3JG97H	10.45
05/28	SQ260528 Square Inc Johanna Skye Lee CUSTOMER ID T36Y7D5KD9VAHSX	14.48
05/29	SQ260529 Square Inc Johanna Skye Lee CUSTOMER ID T3X1MQ8K34EX0Q1	13.18
05/29	EFFECTIVE DATE 5-31-26 INTEREST PAYMENT	0.95
Total deposits, credits and interest		= \$3,607.77



Questions, comments or errors?

For general questions/comments or to report errors about your statement or account, please call us at 1-844-4TRUIST (1-844-487-8478) 24 hours a day, 7 days a week. Truist Care Center teammates are available to assist you from 8am – 8pm EST Monday-Friday and 8am – 5pm EST on Saturday. You may also contact your local Truist branch. To locate a Truist branch in your area, please visit Truist.com.

Electronic fund transfers (For Consumer Accounts Only. Commercial Accounts refer to the Commercial Bank Services Agreement.)

In case of errors or questions about your electronic fund transfers, if you think your statement or receipt is wrong or if you need more information about a transfer on the statement or receipt, IMMEDIATELY call 1-844-487-8478 or write to:

Fraud Management
 P.O. Box 1014
 Charlotte, NC 28201

Tell us as soon as you can, if you think your statement or receipt is wrong, or if you need more information about a transfer listed on the statement or receipt. We must hear from you no later than sixty (60) days after we sent the FIRST statement on which the problem or error appeared.

- Tell us your name and deposit account number (if any)
- Describe the error or transfer you are unsure of, and explain as clearly as you can why you believe it is an error or why you need more information
- Tell us the dollar amount of the suspected error

If you tell us orally, we may require that you also send us your complaint or question in writing within ten (10) business days. We will tell you the results of our investigation within ten (10) business days after we hear from you, and we will correct any error promptly. If we need more time, however, we may take up to forty-five (45) days to investigate your complaint or questions for ATM transactions made within the United States and up to ninety (90) days for new accounts, foreign initiated transactions and point-of-sale transactions. If we decide to do this, we will re-credit your account within ten (10) business days for the amount you think is in error, minus a maximum of \$50. If we ask you to put your complaint in writing, and we do not receive it within ten (10) business days, we may not re-credit your account and you will not have use of the money during the time it takes us to complete our investigation.

Tell us AT ONCE if you believe your access device has been lost or stolen, or someone may have electronically transferred money from your account without your permission, or someone has used information from a check to conduct an unauthorized electronic fund transfer. If you tell us within two (2) business days after you learn of the loss or theft of your access device or the unauthorized transaction, you can lose no more than \$50 if someone makes electronic transfers without your permission.

If you do NOT tell us within two (2) business days after you learn of the loss or theft of your access device or the unauthorized transaction, and we can prove we could have stopped someone from making electronic transfers without your permission if you had told us, you could lose as much as \$500. Also, if your periodic statement shows transfers you did not make, tell us at once. If you do not tell us within sixty (60) days after the statement was mailed to you, you may not get back any money you lost after sixty (60) days if we can prove we could have stopped someone from taking the money if you had told us in time.

Important information about your Truist Ready Now Credit Line Account

Once advances are made from your Truist Ready Now Credit Line Account, an INTEREST CHARGE will automatically be imposed on the account's outstanding "Average daily balance." The INTEREST CHARGE is calculated by applying the "Daily periodic rate" to the "Average daily balance" of your account (including current transactions) and multiplying this figure by the number of days in the billing cycle. To get the "Average daily balance," we take the beginning account balance each day, add any new advances or debits, and subtract any payments or credits and the last unpaid INTEREST CHARGE. This gives us the daily balance. Then we add all of the daily balances for the billing cycle and divide the total by the number of days in the billing cycle. This gives us the "Average daily balance."

Billing Rights Summary

If you believe your **Truist Ready Now Credit Line statement** contains an error, please notify us in writing within sixty (60) days of the date the error FIRST appeared. Written correspondence must be sent to:

Truist Ready Now Credit Line Disputed Payments
 PO Box 849
 Wilson, NC 27894

You may contact us by phone; telephone inquiries do not obligate us to investigate and may result in your responsibility for the disputed amount.

Your written notice should include:

- Your name and account number
- The dollar amount of the suspected error
- A description of the error and an explanation of why you believe it is incorrect

During our investigation process:

- We cannot try to collect the amount in question, or report you as delinquent on that amount
- The change may remain on your statement and accrue interest; however, if an error is confirmed, you will not be liable for the amount in question or any interest or other fees related to that amount
- You are required to pay all other amounts not in dispute
- We can apply any unpaid amount against your credit limit

Mail-in deposits

Deposits can be made at a Truist ATM or using Truist Mobile Banking.

If you wish to mail a deposit, please send a deposit ticket and check to the following address (Please do not send cash):

Central Processing
 MC:306-40-04-25
 P.O. Box 27572
 Richmond, VA 23261-7572

Change of address

If you need to change your address, please visit your local Truist branch or call Truist Care Center at 1-844-4TRUIST (1-844-487-8478).

How to Reconcile Your Account		Outstanding Checks and Other Debits (Section A)			
		Date/Check #	Amount	Date/Check #	Amount
1.	List the new balance of your account from your latest statement here:				
2.	Record any outstanding debits (checks, check card purchases, ATM withdrawals, electronic transactions, etc.) in section A. Record the transaction date, the check number or type of debit and the debit amount. Add up all of the debits, and enter the sum here:				
3.	Subtract the amount in Line 2 above from the amount in Line 1 above and enter the total here:				
4.	Record any outstanding credits in section B. Record the transaction date, credit type and the credit amount. Add up all of the credits and enter the sum here:				
		Outstanding Deposits and Other Credits (Section B)			
5.	Add the amount in Line 4 to the amount in Line 3 to find your balance. Enter the sum here. This amount should match the balance in your register.	Date/Type	Amount	Date/Type	Amount

For more information, please contact your local Truist branch, visit Truist.com or contact us at 1-844-4TRUIST (1-844-487-8478). MEMBER FDIC

P.O. Box 521599 Miami, FL 33152-1599

>004918 6870149 0001 008229 10Z
 PRESERVE AT WILDERNESS LAKE
 COMMUNITY DEVELOPMENT DISTRICT
 250 INTERNATIONAL PKWY STE 208
 LAKE MARY FL 32765

Statement Date: May 31, 2026

Account Number: *****3786

Customer Service Information

 Client Care: 877-779-BANK (2265)

 Web Site: www.bankunited.com

 Bank Address: BankUnited
 P.O. Box 521599
 Miami, FL 33152-1599



Customer Message Center

New Client Care Center Hours: Please refer to the end of this statement for updates to our Client Care Center operating hours.

PUBLIC FUNDS MONEY MARKET Account ***3786**

Account Summary

Statement Balance as of 04/30/2026			\$2,386,832.85
Plus	0	Deposits and Other Credits	\$0.00
Less	1	Withdrawals, Checks, and Other Debits	\$140,000.00
Less		Service Charge	\$0.00
Plus		Interest Paid	\$6,203.02
Statement Balance as of 05/31/2026			\$2,253,035.87

Interest Summary

Beginning Interest Rate	3.25%
Interest Period Days	31
Interest Annual Percentage Yield Earned this Statement Period (APYE)	3.28%
Interest Paid this Statement Period	\$6,203.02
Interest Paid Year to Date	\$35,147.47

Activity By Date

Date	Description	Withdrawals	Deposits	Balance
05/04/2026	WEB TFR TO 009856015814 WEB RF#101256000766	\$140,000.00		\$2,246,832.85

Statement Date: May 31, 2026

Account Number: *****3786

Activity By Date

<i>Date</i>	<i>Description</i>	<i>Withdrawals</i>	<i>Deposits</i>	<i>Balance</i>
05/29/2026	Interest Paid		\$6,203.02	\$2,253,035.87

Rates By Date

<i>Date</i>	<i>Rate</i>	<i>Date</i>	<i>Rate</i>
05/01	3.25%	05/12	3.22%

Balances by Date

<i>Date</i>	<i>Balance</i>	<i>Date</i>	<i>Balance</i>	<i>Date</i>	<i>Balance</i>
04/30	\$2,386,832.85	05/04	\$2,246,832.85	05/29	\$2,253,035.87

Other Balances

Minimum Balance this Statement Period	\$2,246,832.85
---------------------------------------	----------------



Effective Monday, March 2, 2026, the Client Care Center hours will be:

- Monday–Friday: 8:00 AM–7:00 PM ET
- Saturday: 9:00 AM–12:00 PM ET

These updated hours provide better coverage during peak times and faster assistance. You can also manage everyday banking anytime through Online and Mobile Banking providing self-service access outside of call center hours. We appreciate the opportunity to serve you and are committed to delivering an exceptional client experience.

Statement Date: May 31, 2026

Account Number: *****3786

If your account does not balance please check the following carefully:

Have you entered the amount of each check in your checkbook register?

Are the amounts of your deposits and other additions entered in your checkbook register the same as those on this statement?

Have you checked all additions and subtractions in your checkbook register?

Have you carried the correct balance forward when starting a new page in your checkbook register?

**IN CASE OF QUESTIONS OR ERRORS ABOUT YOUR STATEMENT:
PLEASE CALL (TOLL FREE) 1-877-779-BANK (2265) OR WRITE US AT:**BankUnited Operations / EFT Error
7815 NW 148th ST, Miami Lakes, FL 33016**For Consumer Customers Only**

Please contact us if you think your statement is wrong or if you need additional information about a transaction. We must hear from you no later than 60 days after we sent you the FIRST statement on which the error or problem appeared.

1. Tell us your name and account number.
2. Describe the error or the transfer you are unsure about and explain as clearly as you can why you believe there is an error or why you need further information.
3. Tell us the dollar amount of the suspected error.

You may be required to put your request in writing. We will investigate your complaint and will correct any error promptly.

For Electronic Funds Transfers, if we take more than 10 business days to investigate and correct the error, (20 business days if you are a new customer for electronic funds transfers occurring during the first 30 days after the first deposit is made to your account), we will recredit your consumer account for the amount you think is in error (plus interest if your account earns interest), so that you will have the use of the money during the time it takes us to complete our investigation.

For Substitute Checks, if we take more than 10 business days to investigate and correct the error, we will recredit your consumer account for the amount of loss up to the lesser of \$2,500.00 (plus interest if your account earns interest) or the amount of the substitute check. If your account is new (30 days from the date your account was established), has been subject to repeated overdrafts, or we believe the claim is fraudulent, we may delay the availability of recredited funds until we determine the claim is valid or until the 45th day after the claim was submitted.



EXHIBIT 9

The Preserve at Wilderness Lake CDD

Check Detail

May 2026

Type	Num	Date	Name	Item	Account	Paid Amount	Original Amount
Bill Pmt -Check		05/06/2026	Duke Energy		1101000 · BankUnited - Operating		0.00
Bill	8746-5155 MAY-26	05/06/2026	Duke Energy		1202000 · Accounts Payable - GF	0.00	-30.80
TOTAL						0.00	-30.80
Bill Pmt -Check	1427	05/22/2026	Ellen L Dobson - Pet...		1101000 · BankUnited - Operating		-294.09
Bill	2026 JAN-MAY	05/22/2026			1180190 · Nature Center Operations	-31.04	31.96
					1180190 · Nature Center Operations	-10.16	10.47
					1180180 · General Store	-22.52	23.17
					1180190 · Nature Center Operations	-22.77	23.43
					1180190 · Nature Center Operations	-8.73	8.98
					1180210 · Special Events	-1.38	1.42
					1180190 · Nature Center Operations	-3.40	3.50
					1180210 · Special Events	-2.26	2.33
					1180040 · Lodge Repair & Maint.	-19.44	20.00
					1180190 · Nature Center Operations	-23.29	23.96
					1180060 · Lodge Janitor Supplies	-19.41	19.97
					1180060 · Lodge Janitor Supplies	-23.31	23.98
					1180040 · Lodge Repair & Maint.	-38.87	40.00
					1180150 · Resident Services	-2.51	2.58
					1180040 · Lodge Repair & Maint.	-29.15	30.00
					1180190 · Nature Center Operations	-4.85	4.99
					1180040 · Lodge Repair & Maint.	-13.50	13.89
					1180040 · Lodge Repair & Maint.	-14.58	15.00
					1180210 · Special Events	-2.92	3.00
TOTAL						-294.09	302.63
Bill Pmt -Check	1428	05/28/2026	Department of Healt...		1101000 · BankUnited - Operating		-850.00
Bill	51-BID-7815607	05/28/2026			1180100 · Pool Permits	-280.00	280.00
Bill	51-BID-7815608	05/28/2026			1180100 · Pool Permits	-280.00	280.00
Bill	51-BID-7815910	05/28/2026			1180100 · Pool Permits	-145.00	145.00
Bill	51-BID-7815999	05/28/2026			1180100 · Pool Permits	-145.00	145.00
TOTAL						-850.00	850.00
Bill Pmt -Check	EFT041727	05/28/2026	Duke Energy		1101000 · BankUnited - Operating		0.00
TOTAL						0.00	0.00

The Preserve at Wilderness Lake CDD

Check Detail

May 2026

Type	Num	Date	Name	Item	Account	Paid Amount	Original Amount
Bill Pmt -Check	ACH050126	05/01/2026	U.S. Bank		3151001 · DS 2012 Principal		-100,000.00
Bill	050126 Prin 2012	05/01/2026			3531001 · Principal Payment DS 2012	-100,000.00	100,000.00
TOTAL						-100,000.00	100,000.00
Bill Pmt -Check	ACH050126	05/01/2026	U.S. Bank		3151000 · DS 2012 Interest		-26,065.62
Bill	050126 Int 2012	05/01/2026			3510001 · Interest Expense DS 2012	-26,065.62	26,065.62
TOTAL						-26,065.62	26,065.62
Bill Pmt -Check	ACH050126	05/01/2026	U.S. Bank		4151001 · DS 2013 Sinking		-205,000.00
Bill	050126 Prin 2013	05/01/2026			4531001 · Principal Payment DS 2013	-205,000.00	205,000.00
TOTAL						-205,000.00	205,000.00
Bill Pmt -Check	ACH050126	05/01/2026	U.S. Bank		4151000 · DS 2013 Interest		-46,168.76
Bill	050126 Int 2013	05/01/2026			4510001 · Interest Expense DS 2013	-46,168.76	46,168.76
TOTAL						-46,168.76	46,168.76
Bill Pmt -Check	01ACH050426	05/04/2026	Frontier		1101000 · BankUnited - Operating		-450.69
Bill	9960570-060723...	04/07/2026			1180110 · Telephone, Internet, Cable	-450.69	450.69
TOTAL						-450.69	450.69
Bill Pmt -Check	02ACH050426	05/04/2026	BANK UNITED VISA ...		1101000 · BankUnited - Operating		-3,881.14
Bill	APR 2026	04/22/2026			1180210 · Special Events	-69.32	70.00
					1180040 · Lodge Repair & Maint.	-55.36	55.91
					1180250 · Equipment Repair & Repla...	-80.20	80.99
					1180180 · General Store	-46.19	46.64
					1180190 · Nature Center Operations	-37.51	37.88
					1180040 · Lodge Repair & Maint.	-6.14	6.20
					1180210 · Special Events	-20.15	20.35
					1180190 · Nature Center Operations	-14.80	14.95
					1180150 · Resident Services	-15.02	15.17
					1180210 · Special Events	-184.17	185.97
					1180210 · Special Events	-273.33	276.00
					1180150 · Resident Services	-160.43	162.00

The Preserve at Wilderness Lake CDD
Check Detail
 May 2026

Type	Num	Date	Name	Item	Account	Paid Amount	Original Amount
					1180170 · Office Supplies	-19.79	19.99
					1180190 · Nature Center Operations	-13.82	13.96
					1180180 · General Store	-10.94	11.04
					1180190 · Nature Center Operations	-26.64	26.90
					1180210 · Special Events	-39.53	39.91
					1180180 · General Store	-19.74	19.94
					1180210 · Special Events	-42.55	42.96
					1180190 · Nature Center Operations	-39.52	39.90
					1180180 · General Store	-39.56	39.95
					1180210 · Special Events	-29.68	29.97
					1180190 · Nature Center Operations	-55.38	55.92
					1180060 · Lodge Janitor Supplies	-90.75	91.64
					1180210 · Special Events	-49.52	50.00
					1110150 · Website & Email Hosting	-22.97	23.19
					1180190 · Nature Center Operations	-15.83	15.98
					1110120 · Legal Advertising	-111.32	112.40
					1180040 · Lodge Repair & Maint.	-90.16	91.04
					1180190 · Nature Center Operations	-24.11	24.34
					1180180 · General Store	-197.71	199.64
					1180210 · Special Events	-64.77	65.40
					1180150 · Resident Services	-45.03	45.47
					1180260 · Athletic Court Repair & Mai...	-9.90	9.99
					1180060 · Lodge Janitor Supplies	-22.77	22.99
					1180210 · Special Events	-36.17	36.53
					1180040 · Lodge Repair & Maint.	-4.50	4.55
					1180150 · Resident Services	-20.90	21.11
					1180040 · Lodge Repair & Maint.	-46.15	46.60
					1180040 · Lodge Repair & Maint.	-173.91	175.60
					1180190 · Nature Center Operations	-15.83	15.98
					1180210 · Special Events	-64.83	65.46
					1180230 · Fitness Equipment Repair	-385.24	389.00
					1180210 · Special Events	-16.80	16.96
					1180210 · Special Events	-186.84	188.66
					1180210 · Special Events	-32.17	32.48
					1180180 · General Store	-32.17	32.48
					1180180 · General Store	-167.46	169.10
					1180150 · Resident Services	-18.80	18.98
					1180210 · Special Events	-285.62	288.41
					1180210 · Special Events	-257.29	259.80
					1180190 · Nature Center Operations	-15.83	15.98
					1180190 · Nature Center Operations	-22.72	22.94
					1180180 · General Store	-53.30	53.82
TOTAL						-3,881.14	3,919.02

The Preserve at Wilderness Lake CDD
Check Detail
 May 2026

Type	Num	Date	Name	Item	Account	Paid Amount	Original Amount
Bill Pmt -Check	01ACH050626	05/06/2026	Duke Energy		1101000 · BankUnited - Operating		-1,424.27
Bill	0001-3787 Apr26	04/13/2026			1140010 · Electric Utility Services	-1,424.27	1,424.27
TOTAL						-1,424.27	1,424.27
Bill Pmt -Check	01ACH051226	05/12/2026	Frontier		1101000 · BankUnited - Operating		-125.98
Bill	9299402-041519...	04/15/2026			1180110 · Telephone, Internet, Cable	-125.98	125.98
TOTAL						-125.98	125.98
Bill Pmt -Check	01ACH051926	05/19/2026	Frontier		1101000 · BankUnited - Operating		-145.49
Bill	1592085-030513...	04/22/2026			1180110 · Telephone, Internet, Cable	-145.49	145.49
TOTAL						-145.49	145.49
Bill Pmt -Check	EFT052026	05/20/2026	FL Dept. of Rev.		1101000 · BankUnited - Operating		-262.21
Bill	April 2026	05/19/2026			1202005 · Sales Tax Payable	-262.21	262.21
TOTAL						-262.21	262.21
Bill Pmt -Check	01ACH052626	05/26/2026	Pasco County Utilities		1101000 · BankUnited - Operating		-333.12
Bill	0350530-24410519	05/05/2026			1140050 · Water / Sewer Services	-333.12	333.12
TOTAL						-333.12	333.12
Bill Pmt -Check	02ACH052626	05/26/2026	Pasco County Utilities		1101000 · BankUnited - Operating		-89.76
Bill	0350555-24410524	05/05/2026			1140050 · Water / Sewer Services	-89.76	89.76
TOTAL						-89.76	89.76
Bill Pmt -Check	03ACH052626	05/26/2026	Pasco County Utilities		1101000 · BankUnited - Operating		-11.00
Bill	0350560-24410525	05/05/2026			1140050 · Water / Sewer Services	-11.00	11.00
TOTAL						-11.00	11.00

The Preserve at Wilderness Lake CDD

Check Detail

May 2026

Type	Num	Date	Name	Item	Account	Paid Amount	Original Amount
Bill Pmt -Check	04ACH052626	05/26/2026	Pasco County Utilities		1101000 · BankUnited - Operating		-11.00
Bill	0350550-24410523	05/05/2026			1140050 · Water / Sewer Services	-11.00	11.00
TOTAL						-11.00	11.00
Bill Pmt -Check	05ACH052626	05/26/2026	Pasco County Utilities		1101000 · BankUnited - Operating		-34.42
Bill	0350540-24410521	05/05/2026			1140050 · Water / Sewer Services	-34.42	34.42
TOTAL						-34.42	34.42
Bill Pmt -Check	06ACH052626	05/26/2026	Pasco County Utilities		1101000 · BankUnited - Operating		-11.00
Bill	0350565- 244105...	05/05/2026			1140050 · Water / Sewer Services	-11.00	11.00
TOTAL						-11.00	11.00
Bill Pmt -Check	07ACH052626	05/26/2026	Pasco County Utilities		1101000 · BankUnited - Operating		-2,066.24
Bill	0350545-24410522	05/05/2026			1140050 · Water / Sewer Services	-2,066.24	2,066.24
TOTAL						-2,066.24	2,066.24
Bill Pmt -Check	08ACH052626	05/26/2026	Waste Connections ...		1101000 · BankUnited - Operating		-1,051.63
Bill	8880870W425	05/20/2026			1140030 · Garbage Recreation Facility	-1,051.63	1,051.63
TOTAL						-1,051.63	1,051.63
Bill Pmt -Check	01ACH052826	05/28/2026	Duke Energy		1101000 · BankUnited - Operating		-12,930.13
Bill	0001-3381 MAY26	05/06/2026			1140010 · Electric Utility Services	-12,930.13	12,930.13
TOTAL						-12,930.13	12,930.13
Bill Pmt -Check	02ACH052826	05/28/2026	Duke Energy		1101000 · BankUnited - Operating		-30.80
Bill	8746-4930 MAY26	05/06/2026			1140010 · Electric Utility Services	-30.80	30.80
TOTAL						-30.80	30.80

The Preserve at Wilderness Lake CDD
Check Detail
 May 2026

Type	Num	Date	Name	Item	Account	Paid Amount	Original Amount
Bill Pmt -Check	101156	05/04/2026	A Total Solution, Inc		1101000 · BankUnited - Operating		-600.00
Bill	000203001	05/01/2026			1180140 · Security System Maint.	-600.00	600.00
TOTAL						-600.00	600.00
Bill Pmt -Check	101157	05/04/2026	Pasco Sheriff's Office		1101000 · BankUnited - Operating		-2,200.00
Bill	I-20264-12722	04/27/2026			1130010 · Off Duty Deputy	-2,200.00	2,200.00
TOTAL						-2,200.00	2,200.00
Bill Pmt -Check	101158	05/04/2026	McNatt Plumbing Co...		1101000 · BankUnited - Operating		-185.00
Bill	45411590	04/30/2026			1180040 · Lodge Repair & Maint.	-185.00	185.00
TOTAL						-185.00	185.00
Bill Pmt -Check	101159	05/04/2026	Romaner Graphics		1101000 · BankUnited - Operating		-650.00
Bill	23078	04/22/2026			1180040 · Lodge Repair & Maint.	-650.00	650.00
TOTAL						-650.00	650.00
Bill Pmt -Check	101160	05/04/2026	Himes Electrical Ser...		1101000 · BankUnited - Operating		-163.75
Bill	25495	05/01/2026			1180090 · Pool Repair & Maint.	-163.75	163.75
TOTAL						-163.75	163.75
Bill Pmt -Check	101161	05/04/2026	RedTree Landscape ...		1101000 · BankUnited - Operating		-15,310.56
Bill	33907	04/20/2026			1150100 · Irrigation Repair & Maint.	-31.31	31.31
Bill	33915	04/20/2026			1150100 · Irrigation Repair & Maint.	-279.25	279.25
Bill	34062	05/01/2026			1150010 · Landscape Maintenance	-12,900.00	12,900.00
					1150100 · Irrigation Repair & Maint.	-1,100.00	1,100.00
					1150094 · Hardwood Tree Pruning	-1,000.00	1,000.00
TOTAL						-15,310.56	15,310.56

The Preserve at Wilderness Lake CDD
Check Detail
 May 2026

Type	Num	Date	Name	Item	Account	Paid Amount	Original Amount
Bill Pmt -Check	101162	05/04/2026	DCSI, Inc.		1101000 · BankUnited - Operating		-670.00
Bill	35080	04/22/2026			1180040 · Lodge Repair & Maint. 1180160 · Resident ID Card	-145.00 -525.00	145.00 525.00
TOTAL						-670.00	670.00
Bill Pmt -Check	101163	05/04/2026	CDW Government L...		1101000 · BankUnited - Operating		-301.50
Bill	042226	04/22/2026			1180170 · Office Supplies	-301.50	301.50
TOTAL						-301.50	301.50
Bill Pmt -Check	101164	05/04/2026	Arrow Exterminators		1101000 · BankUnited - Operating		-1,185.00
Bill	66908282	04/17/2026			1180040 · Lodge Repair & Maint.	-1,185.00	1,185.00
TOTAL						-1,185.00	1,185.00
Bill Pmt -Check	101165	05/04/2026	Cooper Pools Inc.		1101000 · BankUnited - Operating		-547.22
Bill	1530	04/22/2026			1180090 · Pool Repair & Maint.	-547.22	547.22
TOTAL						-547.22	547.22
Bill Pmt -Check	101166	05/04/2026	Fitness Logic		1101000 · BankUnited - Operating		-125.00
Bill	129573	04/29/2026			1180220 · Fitness Equipment Maint.	-125.00	125.00
TOTAL						-125.00	125.00
Bill Pmt -Check	101167	05/04/2026	Palm Beach Security...		1101000 · BankUnited - Operating		-522.00
Bill	12874	04/28/2026			1180040 · Lodge Repair & Maint.	-522.00	522.00
TOTAL						-522.00	522.00
Bill Pmt -Check	101168	05/07/2026	FitRev Inc		1101000 · BankUnited - Operating		-14,495.40
Bill	38644	05/07/2026			2510000 · Capital Reserve	-14,495.40	14,495.40
TOTAL						-14,495.40	14,495.40

The Preserve at Wilderness Lake CDD

Check Detail

May 2026

Type	Num	Date	Name	Item	Account	Paid Amount	Original Amount
Bill Pmt -Check	101169	05/11/2026	Vesta District Servic...		1101000 · BankUnited - Operating		-40,915.28
Bill	432291	04/30/2026			1180010 · Contract - Management Fe...	-4,635.00	4,635.00
					1180020 · Contract - Employee Salari...	-36,280.28	36,280.28
TOTAL						-40,915.28	40,915.28
Bill Pmt -Check	101170	05/11/2026	Cooper Pools Inc.		1101000 · BankUnited - Operating		-7,532.89
Bill	2026-1440	05/01/2026			1180080 · Pool Service Contract	-6,438.50	6,438.50
Bill	731	05/01/2026			2510000 · Capital Reserve	-1,094.39	1,094.39
TOTAL						-7,532.89	7,532.89
Bill Pmt -Check	101171	05/11/2026	McNatt's Cleaners		1101000 · BankUnited - Operating		-60.80
Bill	80602	05/01/2026			1180040 · Lodge Repair & Maint.	-60.80	60.80
TOTAL						-60.80	60.80
Bill Pmt -Check	101172	05/11/2026	Palm Beach Security...		1101000 · BankUnited - Operating		-476.00
Bill	12881	05/04/2026			1180040 · Lodge Repair & Maint.	-476.00	476.00
TOTAL						-476.00	476.00
Bill Pmt -Check	101173	05/11/2026	Himes Electrical Ser...		1101000 · BankUnited - Operating		-140.00
Bill	25391	03/18/2026			1180040 · Lodge Repair & Maint.	-140.00	140.00
TOTAL						-140.00	140.00
Bill Pmt -Check	101174	05/11/2026	RedTree Landscape ...		1101000 · BankUnited - Operating		-2,100.00
Bill	34077	05/05/2026			1150090 · Tree Trimming and Removal	-500.00	500.00
Bill	34078	05/05/2026			1150090 · Tree Trimming and Removal	-800.00	800.00
Bill	34075	05/05/2026			1150090 · Tree Trimming and Removal	-400.00	400.00
Bill	34074	05/05/2026			1150090 · Tree Trimming and Removal	-400.00	400.00
TOTAL						-2,100.00	2,100.00

The Preserve at Wilderness Lake CDD

Check Detail

May 2026

Type	Num	Date	Name	Item	Account	Paid Amount	Original Amount
Bill Pmt -Check	101175	05/11/2026	DCSI, Inc.		1101000 · BankUnited - Operating		-494.00
Bill	35092	04/23/2026			1180250 · Equipment Repair & Repla...	-349.00	349.00
					1180040 · Lodge Repair & Maint.	-145.00	145.00
TOTAL						-494.00	494.00
Bill Pmt -Check	101176	05/11/2026	Sunrise Propane		1101000 · BankUnited - Operating		-679.16
Bill	U111N226	05/01/2026			1140020 · Gas Utility Services	-679.16	679.16
TOTAL						-679.16	679.16
Bill Pmt -Check	101177	05/11/2026	10-S Tennis Supply ...		1101000 · BankUnited - Operating		-151.89
Bill	175392	05/06/2026			1180150 · Resident Services	-151.89	151.89
TOTAL						-151.89	151.89
Bill Pmt -Check	101178	05/13/2026	Brletic Dvorak Inc		1101000 · BankUnited - Operating		-945.00
Bill	2411	05/01/2026			1110040 · District Engineer	-945.00	945.00
TOTAL						-945.00	945.00
Bill Pmt -Check	101179	05/13/2026	Vesta District Servic...		1101000 · BankUnited - Operating		-7,158.50
Bill	432480	05/01/2026			1110030 · District Management	-3,181.67	3,181.67
					1110100 · Accounting Services	-2,232.00	2,232.00
					1110020 · Administrative Services	-762.17	762.17
					1110090 · Assessment Roll	-491.33	491.33
					1110080 · Financial & Revenue Colle...	-491.33	491.33
TOTAL						-7,158.50	7,158.50
Bill Pmt -Check	101180	05/13/2026	10-S Tennis Supply ...		1101000 · BankUnited - Operating		-68.89
Bill	175471	05/08/2026			1180260 · Athletic Court Repair & Mai...	-68.89	68.89
TOTAL						-68.89	68.89

The Preserve at Wilderness Lake CDD
Check Detail
 May 2026

Type	Num	Date	Name	Item	Account	Paid Amount	Original Amount
Bill Pmt -Check	101181	05/13/2026	RedTree Landscape ...		1101000 · BankUnited - Operating		-800.00
Bill	34138	05/11/2026			1150090 · Tree Trimming and Removal	-800.00	800.00
TOTAL						-800.00	800.00
Bill Pmt -Check	101182	05/13/2026	CDW Government L...		1101000 · BankUnited - Operating		-1,621.59
Bill	PVZL231	04/17/2026			1180170 · Office Supplies	-1,621.59	1,621.59
TOTAL						-1,621.59	1,621.59
Bill Pmt -Check	101183	05/18/2026	Agnieszka Fisher		1101000 · BankUnited - Operating		-200.00
Bill	050726 BOS	05/13/2026			1110010 · Supervisor Fees	-200.00	200.00
TOTAL						-200.00	200.00
Bill Pmt -Check	101184	05/18/2026	Cooper Pools Inc.		1101000 · BankUnited - Operating		-9,397.92
Bill	761	05/15/2026			2510000 · Capital Reserve	-1,536.32	1,536.32
Bill	760	05/15/2026			2510000 · Capital Reserve	-7,861.60	7,861.60
TOTAL						-9,397.92	9,397.92
Bill Pmt -Check	101185	05/18/2026	Fitness Logic		1101000 · BankUnited - Operating		-350.98
Bill	129836	05/14/2026			1180230 · Fitness Equipment Repair	-350.98	350.98
TOTAL						-350.98	350.98
Bill Pmt -Check	101186	05/18/2026	GHS, LLC		1101000 · BankUnited - Operating		-6,181.67
Bill	2026-362	05/13/2026			1160020 · Monthly Aquatic Weed Co...	-2,875.00	2,875.00
					1160030 · Wetland Staff Oversight	-166.67	166.67
					1160040 · Private Resident Consultati...	-65.00	65.00
					1160050 · Nuisance Species Control	-875.00	875.00
					1160070 · Wetland Routine Cleanup	-2,200.00	2,200.00
TOTAL						-6,181.67	6,181.67

The Preserve at Wilderness Lake CDD
Check Detail
 May 2026

Type	Num	Date	Name	Item	Account	Paid Amount	Original Amount
Bill Pmt -Check	101187	05/18/2026	Holly Ruhlig		1101000 · BankUnited - Operating		-200.00
Bill	050726 BOS	05/13/2026			1110010 · Supervisor Fees	-200.00	200.00
TOTAL						-200.00	200.00
Bill Pmt -Check	101188	05/18/2026	Straley Robin Vericker		1101000 · BankUnited - Operating		-810.50
Bill	28327	05/12/2026			1110170 · District Counsel	-810.50	810.50
TOTAL						-810.50	810.50
Bill Pmt -Check	101189	05/18/2026	Cool Coast Heating ...		1101000 · BankUnited - Operating		-488.00
Bill	1351274	05/13/2026			1180040 · Lodge Repair & Maint.	-488.00	488.00
TOTAL						-488.00	488.00
Bill Pmt -Check	101190	05/18/2026	PSA Horticultural		1101000 · BankUnited - Operating		-1,100.00
Bill	1694	05/14/2026			1150060 · Landscape Inspection Serv...	-1,100.00	1,100.00
TOTAL						-1,100.00	1,100.00
Bill Pmt -Check	101191	05/18/2026	Virginia B. Edwards		1101000 · BankUnited - Operating		-200.00
Bill	050726 BOS	05/13/2026			1110010 · Supervisor Fees	-200.00	200.00
TOTAL						-200.00	200.00
Bill Pmt -Check	101192	05/18/2026	RedTree Landscape ...		1101000 · BankUnited - Operating		-498.98
Bill	34158	05/12/2026			1150100 · Irrigation Repair & Maint.	-288.98	288.98
Bill	34157	05/12/2026			1150100 · Irrigation Repair & Maint.	-210.00	210.00
TOTAL						-498.98	498.98
Bill Pmt -Check	101193	05/18/2026	Inteligy Tampa Bay ...		1101000 · BankUnited - Operating		-330.00
Bill	24743	05/15/2026			1180110 · Telephone, Internet, Cable	-330.00	330.00
TOTAL						-330.00	330.00

The Preserve at Wilderness Lake CDD

Check Detail

May 2026

Type	Num	Date	Name	Item	Account	Paid Amount	Original Amount
Bill Pmt -Check	101194	05/18/2026	John Staples		1101000 · BankUnited - Operating		-200.00
Bill	050726 BOS	05/13/2026			1110010 · Supervisor Fees	-200.00	200.00
TOTAL						-200.00	200.00
Bill Pmt -Check	101195	05/18/2026	A Total Solution, Inc		1101000 · BankUnited - Operating		-74.00
Bill	i10178	05/07/2026			1180040 · Lodge Repair & Maint.	-37.00	37.00
Bill	i10205	05/07/2026			1180040 · Lodge Repair & Maint.	-37.00	37.00
TOTAL						-74.00	74.00
Bill Pmt -Check	101196	05/18/2026	Heather Hepner		1101000 · BankUnited - Operating		-200.00
Bill	050726 BOS	05/13/2026			1110010 · Supervisor Fees	-200.00	200.00
TOTAL						-200.00	200.00
Bill Pmt -Check	101197	05/21/2026	RedTree Landscape ...		1101000 · BankUnited - Operating		-9,744.00
Bill	34256	05/19/2026			1150040 · Landscape Replacement P...	-984.00	984.00
Bill	34255	05/19/2026			1180280 · Playground Mulch	-7,225.00	7,225.00
Bill	34257	05/19/2026			1150040 · Landscape Replacement P...	-390.00	390.00
Bill	34258	05/19/2026			1150040 · Landscape Replacement P...	-500.00	500.00
Bill	34259	05/19/2026			1150040 · Landscape Replacement P...	-545.00	545.00
Bill	34260	05/19/2026			1150040 · Landscape Replacement P...	-100.00	100.00
TOTAL						-9,744.00	9,744.00
Bill Pmt -Check	101198	05/21/2026	State Wildlife Trapp...		1101000 · BankUnited - Operating		-1,200.00
Bill	2149	05/18/2026			1180200 · Wildlife Management Servi...	-1,200.00	1,200.00
TOTAL						-1,200.00	1,200.00
Bill Pmt -Check	101199	05/21/2026	Electro Sanitation S...		1101000 · BankUnited - Operating		-2,499.81
Bill	INV-000193	05/17/2026			1180050 · Lodge Janitor Services	-2,100.00	2,100.00
Bill	INV-000194	05/17/2026			1180060 · Lodge Janitor Supplies	-399.81	399.81
TOTAL						-2,499.81	2,499.81

The Preserve at Wilderness Lake CDD
Check Detail
 May 2026

Type	Num	Date	Name	Item	Account	Paid Amount	Original Amount
Bill Pmt -Check	101200	05/21/2026	Cooper Pools Inc.		1101000 · BankUnited - Operating		-420.00
Bill	768	05/15/2026			1180090 · Pool Repair & Maint.	-420.00	420.00
TOTAL						-420.00	420.00
Bill Pmt -Check	101201	05/21/2026	Ready Refresh		1101000 · BankUnited - Operating		-47.98
Bill	36D0006240923	05/12/2026			1180150 · Resident Services	-47.98	47.98
TOTAL						-47.98	47.98
Bill Pmt -Check	101202	05/21/2026	10-S Tennis Supply ...		1101000 · BankUnited - Operating		-306.98
Bill	175674	05/18/2026			1180260 · Athletic Court Repair & Mai...	-306.98	306.98
TOTAL						-306.98	306.98
Bill Pmt -Check	101203	05/22/2026	ProPet Distributors		1101000 · BankUnited - Operating		-1,160.16
Bill	2003522	03/12/2026			1180290 · Dog Waste Station Supplies	-1,160.16	1,160.16
TOTAL						-1,160.16	1,160.16
Bill Pmt -Check	101204	05/28/2026	Fitness Logic		1101000 · BankUnited - Operating		-125.00
Bill	130004	05/22/2026			1180220 · Fitness Equipment Maint.	-125.00	125.00
TOTAL						-125.00	125.00
Bill Pmt -Check	101205	05/28/2026	MPLC		1101000 · BankUnited - Operating		-4,242.70
Bill	504477145	05/26/2026			1180180 · General Store	-4,242.70	4,242.70
TOTAL						-4,242.70	4,242.70
Bill Pmt -Check	101206	05/28/2026	A Total Solution, Inc		1101000 · BankUnited - Operating		-223.00
Bill	i10612	05/13/2026			1180130 · Security System Monitoring	-223.00	223.00
TOTAL						-223.00	223.00

The Preserve at Wilderness Lake CDD
Check Detail
 May 2026

Type	Num	Date	Name	Item	Account	Paid Amount	Original Amount
Bill Pmt -Check	101207	05/29/2026	Grant Hemond & As...		1101000 · BankUnited - Operating		-763.00
Bill	469531-1074	05/28/2026			1180210 · Special Events	-416.50	416.50
Bill	469532-1075	05/28/2026			1180210 · Special Events	-346.50	346.50
TOTAL						-763.00	763.00



duke-energy.com
877.372.8477

Your Energy Bill

Service address

THE PRESERVE WILDERNESS LAKE
7739 CITRUS BLOSSOM DR
SIGN HERONS WOOD

Bill date May 6, 2026
For service Apr 3 - May 4
32 days

Account number **9100 8746 5155**

Billing summary

Previous Amount Due	\$-138.91
<i>Payment Received</i>	0.00
Current Electric Charges	30.00
Taxes	0.80
Credit Amount, Do Not Pay	\$-108.11

Duke Energy Florida utilized fuel in the following proportions to generate your power: Coal 10.9%, Purchased Power 2%, Gas 78.9%, Oil 0.1%, Nuclear 0%, Solar 8.1% (For prior 12 months ending March 31, 2026).

Your usage snapshot

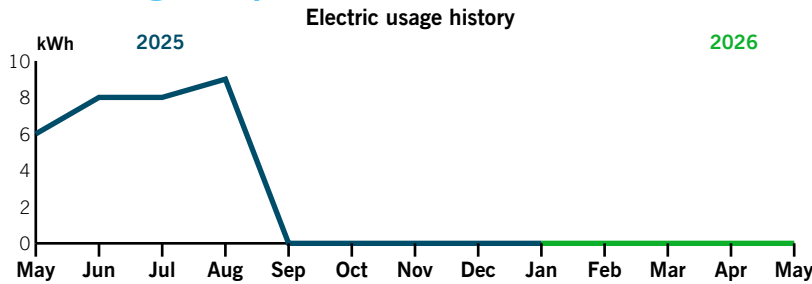
**Average temperature in degrees**

81° 82° 84° 84° 81° 75° 67° 65° 60° 60° 71° 74° 79°

	Current Month	May 2025	12-Month Usage	Avg Monthly Usage
Electric (kWh)	0	6	25	2
Avg. Daily (kWh)	0	0	0	

12-month usage based on most recent history

Mail your payment at least 7 days before the due date or pay instantly at duke-energy.com/billing. Payments for this statement within 90 days from the bill date will avoid a 1.0% late payment charge.

Please return this portion with your payment. Thank you for your business.

Amount due

\$0.00

No payment is required at this time.

Account number
9100 8746 5155



Duke Energy Return Mail
PO Box 1090
Charlotte, NC 28201-1090

\$ _____ \$ _____
Add here, to help others with a contribution to Share the Light **Amount enclosed**

THE PRESERVE WILDERNESS LAKE
250 INTERNATIONAL PKWY STE 208
LAKE MARY FL 32746

Duke Energy Payment Processing
PO Box 1094
Charlotte, NC 28201-1094

8891008746515500066000000000000000000000308000000000000



Your usage snapshot - Continued

Current electric usage for meter number 4426449	
Actual reading on May 4	406
Previous reading on Apr 3	- 406
<hr/>	
Energy Used	0 kWh
Billed kWh	0.000 kWh



A kilowatt-hour (kWh) is a measure of the energy used by a 1,000-watt appliance in one hour. A 10-watt LED lightbulb would take 100 hours to use 1 kWh.

Billing details - Electric

Billing Period - Apr 03 26 to May 04 26	
Meter - 4426449	
Customer Charge	\$17.92
Minimum Bill Adjustment	12.08
<hr/>	
Total Current Charges	\$30.00

The total charges incurred during this billing period are below the minimum expenses necessary to equitably provide and maintain reliable electric service to all facilities across the state. When the combined monthly customer, energy, fuel, and other charges fall below a \$30 threshold, customers will see the difference noted as a Minimum Bill Adjustment under the Billing Details section. Learn more about the minimum charge adjustment and additional customer charges at duke-energy.com/minimum.

Your current rate is General Service Non-Demand Sec (GS-1).

For a complete listing of all Florida rates and riders, visit duke-energy.com/rates

Billing details - Taxes

Regulatory Assessment Fee	\$0.03
Gross Receipts Tax	0.77
<hr/>	
Total Taxes	\$0.80

DISTRICT CHECK REQUEST

Today's Date: 5-21-2026

District Name: The Preserve at Wilderness Lake CDD

Check Amount: \$294.09

Payable To: Ellen Dobson – Petty Cash

GL Code: See Petty Cash Reconciliation Sheet

Check Description: Petty Cash Reimbursement

Where is the check to be mailed?

The Preserve at Wilderness Lake

21320 Wilderness Lake Blvd.

Land O' Lakes, FL 34637

Regular Mail

UPS Ground (cannot be to a PO Box, must include a contact name & telephone number)

Approved Signature: Tish Dobson

Invoice copy attached

PRESERVE AT WILDERNESS LAKE

Ellen L Dobson - Petty Cash

Date 1/21/2026 Type Reference
Bill 2026 NOV-JAN

1399

Payment
289.05
289.05

Original Amt. 289.05
Balance Due 289.05
1/22/2026 Discount
Check Amount

BankUnited - Operatin

289.05

PET SUPPLIES PLUS.

21705 Village Lakes Shopping Center Dr
 Land O Lakes, FL 34639
 USA
 813-575-9728

Publix

Coffee Commons
 2121 Coffee Plaza
 Land O Lakes, FL 34639
 Store Manager: Elliott
 813-948-9819



0877 2HR 035 628

Store: 4071 0418 1/15/2025
 Register: 40100 1100 12:55 PM
 Register ID: 40100110534312
 Operator ID: 401133
 Team Leader: Branda
 Release #: 41028525/666
 Release: Tich Hansen

ITEM NAME	QTY	PRICE	AMOUNT
PLAY ON BEDDING ASPEN 11X12 756683144521	2 Unit	\$15.98	\$31.96

Subtotal \$31.96
 Total Tax \$0.00
 Total \$31.96

CASH Visa AMEX \$31.96

ALL PURCHASES ARE SUBJECT TO A 30-DAY RETURN POLICY
 ALL REFUNDS MUST BE CREDITED TO ORIGINAL
 PUBLIX CARD. AMOUNTS MAY VARY BY OUR MANUFACTURER'S
 REFUND/EXCHANGE POLICY MAY VARY BY INDEPENDENTLY
 OWNED AND OPERATED STORES. LOCAL LAWS.

CILANTRO	1.49
GM GRD BABY KALE	4.49
GM GRD SERRANO SOZ	4.49
G/AD FR GRAC FRZ	5.79
G/AD FR GRAC FRZ	5.79
BRISK TWIN TEA	11.99
G/AD ASSTAR LEM/LM	5.79
G/AD ASSTAR LEM/LM	5.79
Promotion	5.79
Promotion	5.79

n.c.
 10-47
 B.S.

TAX EXEMPT

Order Total 31.96
 Grand Total 31.96
 Credit Payment 31.96

TAX FIFTYEN 1.07
 Change 0.00

Publix Savings
 Special Price Savings 11.58

 * Your Savings at Publix *
 * 11.58 *

Receipt ID: 0877 2HR 035 628

PRESID!
 Trade #: 036369
 Reference #: 1025300005
 Acct #: XXXXXXXXXX 618
 Purchase VISA
 Amount: \$31.96
 Auth #: 607013

CREDIT CARD PURCHASE
 AMERICAN EXPRESS VISA CREDIT
 Entry Method: Chip Read
 Mode: Issuer

Your Cashier was KATHLEEN R.

02/17/2025 0:00 30871 1002 5628 14008

Publix

Arbor Square at Fortnetter
3801 Land O Lakes Blvd
Land O Lakes, FL 34638
Store Manager: David Jones
613 950-3394



N-10

1142 788 063 596

GN ORG SPINACH 5OZ	4.49	F
LA ORG BAG [®] PALL	4.49	F
LA ORG BAG[®] PALL	4.49	
MILK SKIM 1% CANTINA	3.99	F*
NONFAT		
3 - 2.49	7.47	F*
ORG CANTINA SKIMM	2.91	F*
Sub Total	27.42	
Sales Tax	0.28	
Grand Total	27.70	
Tax	27.70	
Change	\$23.43	
	0.00	

Receipt ID: 1142 788 063 596

PF03TG
Trace #: 000000
Reference #: 123001240
Acct #: 804237220087018
Purchase Y1CA
Amount \$27.70
Auth #: 000000

STORE CARD
STOCK/SALES
Entry Method
Code: 1984JH02
VISA CREDIT
Chip Read
Faster

See cashier for details

12/20/2016 12:04 PM 1142 788 063 596

Join the Publix family!
Apply today at publix.jobs
We're an equal opportunity employer.

Publix Super Markets, Inc.

Publix

Publix Super Market #000
 139 East O Lake Rd
 East O Lake, IL 60021
 Store Manager: Kevin Jones
 813-996-3331



Receipt #001 142 NR 001 025

N.C. 8-18 P.B.	(GM ORG BABY KALE	4.49	F
	CH 10% (PINA) 5lb	4.49	F
	SAWADA, 10 lb 100% organic	1.49	F
	Order Total	10.46	
	Tax and Fee	5.00	
	Grand Total	15.46	
	cash	20.00	
	Change	4.54	

Receipt #001 142 NR 001 025

This receipt was generated

07/23/2026 14:50:31 142 NR 001 025

Join the Publix Team!
 Apply today at apply.publix.jobs
 We're an equal opportunity employer.

Publix Super Markets, Inc.

PUBLIX

The Livingston Marketplace
2801 E. County Line Rd.
Lutz, FL 33559
Store Manager: Ryan Mulvaney
813-949-2812



1821 3HR 063 725

KR CLB/MONT/JK CHK			
1 @ 2 FOR	6.00	3.00	F
You Saved	1.99		
KR CLB/MONT/JK CHK			
1 @ 2 FOR	6.00	3.00	F
You Saved	1.99		
KR CLB/MONT/JK CHK			
1 @ 2 FOR	6.00	3.00	F
You Saved	1.99		
KR CLB/MONT/JK CHK			
1 @ 2 FOR	6.00	3.00	F
You Saved	1.99		
GORDON'S CHS DIP HLW		6.79	F
GORDON'S HMTL QUECO		6.79	F
50/50			
1 @ 2 FOR	6.00	3.00	F
You Saved	0.99		
ORG BABY KALE			
1 @ 2 FOR	7.00	3.50	F
You Saved	0.99		
BK SOUR CREAM		2.99	F
BK SOUR CREAM		2.99	F
1@ FRENCH VAN HG		6.59	F
1@ FRENCH VAN HG		6.59	F
BK CC SMOOTH&CRMY		4.95	F
ANGEL SWEET TOMATO		3.99	F
LETTUCE ICEBERG		2.69	F
TOMATO ON THE VINE			
1.18 lb @ 2.617 lb		3.08	F
CUCUMBERS		0.99	F
ITALIAN SAUSAGE		6.09	F
KYL SLICED HAM		15.79	F
Club Publix Perk		3.00	F

Order Total	90.42	
Sales Tax	0.00	
Grand total	90.42	
Credit	Payment	90.42

- PRES10!
Trace #: 057100
Reference #: 1318931405
Acct #: XXXXX7818
Purchase VISA
Amount: \$90.42
Auth #: 662992

Your cashier was Connor J.

03/09/2020 16:46 51821 4106 3/25 00218

4/18/2026 4:34:59 PM
Order Number: 2049347
Circle K 2707575
7767 Land O'Lakes Blvd
Land O'Lakes, FL 34638
(813) 929-8788

Register:2 3716832, Aryonna

Prepay Pump # 8	\$20.00
Sub. Total:	\$20.00
Tax:	\$0.00
Penny Rounding:	\$0.00
Total:	\$20.00
Discount Total:	\$0.00
Cash	\$20.00
Change	\$0.00

**Thank You
Come Again**

PET SUPPLIES PLUS.

21709 Village Lakes Shopping Center Dr
Land O Lakes, FL 34639
USA
813-575-9738

Store: 4011 Date: 4/3/2026
Register: 401101 Time: 05:54 PM
Receipt #: 30110110549013
Operator ID: 401120
Team Member: LUIS L
Rewards #: 410065204774
Neighbor: Terri A. Ly

ITEM NAME	QTY	PRICE	AMT
NICE TO GO PINKIE HOUSE SCT 091037003003	1 Unit	\$10.98	\$10.98
NIL NIT 100 TRAIL PROTRON 875 07491400093	1 Unit	\$12.98	\$12.98
Subtotal			\$23.96
Total tax			\$0.00
Total			\$23.96
CASH	Visa Debit	1.0%	\$23.96

ALL PURCHASES ARE SUBJECT TO A 30 DAY RETURN WITH RECEIPT. REFUNDS MUST BE CREDITED TO ORIGINAL PAYMENT FORM. RETURNS HAVE LIMITED 14-DAY GUARANTEE. REFUND/EXCHANGE POLICY MAY VARY BY INDEPENDENTLY OWNED AND OPERATED FRANCHISE LOCATIONS.

** YOU CAN GET YOUR OWN PET SUPPLIES PLUS STORE **
CONTACT US TO LEARN MORE:
franchising@pet-supplies-plus.com
usa.pet-supplies-plus@franchise.com

*** YOUR OPINION MATTERS ***
TELL US ABOUT YOUR EXPERIENCE BY VISITING:
WWW.PSP40000.COM



Publix

Collier Commons
2121 Collier Pkwy
Land O Lakes, FL 34639
Store Manager: Elliott
813-940-9819



0877 488 519 573

PUB LTX 100C GLOVE	11.99 T
PUB LTX 100C GLOVE	11.99 T
TAX EXEMPT	
Order Total	23.98
Grand Total	23.98
Cash	30.00
TAX FORGIVEN	1.68
Change	6.02

Receipt ID: 0877 488 519 573

Your cashier was Heidi

04/17/2020 8:10 50877 0151 9573 00416

Join the Publix family!
Apply today at apply.publix.jobs.
We're an equal opportunity employer.

Publix Super Markets, Inc.

Publix

Arthur Capone of Conventum
7830 Land O'Lakes Blvd.
Land O'Lakes, FL 34638
Store Manager: David Jones
813-996-3391

4/25/2026 12:20:4
Order Number: 2859853
Circle K 2787575
7787 Land O'Lakes Bl
Land O'Lakes FL 34638
(813) 929-8788
Term: 2787575_SPW1
Appr: 3984324878-
UNL-REG
PUMP No. 88
Gallons 10.155
PRICE/G \$3.939
TOTAL FUEL \$40.00
TOTAL SALE \$48.00
Generic Mobile
XXXXXXXXXXXXXXXXXX
Cloud



142 408 067 820

ICE 7 LB		
1 * 2 PBT	5.00	2.50 T F
Order Total		2.50
Taxes Tax		0.18
Grand Total		2.68
Cash		5.00
Change		2.32

Survey Code #425114241067520

Receipt ID: 111 408 067 820

Your cashier was Alex

04/25/2026 12:41 51142 8139963391 01224

Join the Publix family!
Apply today at apply.publix.jobs.
We're an equal opportunity employer.

Publix Super Markets, Inc.

04/25/2026 12:16:11

I agree to pay the
above Total Amount
according to Card
Issuer Agreement.

THANK YOU
HAVE A NICE DAY



**Circle K -
2707575**

7767 Land O'Lakes
Blvd
Land O'Lakes, FL
34638

2026-05-02 12:56:29 PM
TRX #KLD7TJRKU4E561 - Sale
4028-3904-326926

Item	Price
PREPAID FUEL MASHGIN	\$30.00
LPC: 999999050232 Pump number: 11	

Sub Total	\$30.00
Taxes	\$0.00
Total	\$30.00

Cash paid: \$30.00

Pump: 11

Reserved amount: \$30.00

AC: 3904326926-

\$30.00 charged to Cash

Scan for updated receipt/change after
fueling.



Thank You For Using Mashgin

NC

PUBLIX

Address: 1142 S.W. 70th Ave
Lakeland, FL 34601
Phone: 888-996-3741

AMOUNT REMAINING:	4.00	1
Order Total	4.00	
Sales Tax	0.00	
Grand Total	4.00	
Credit	Payment	4.00
Change	0.00	

Receipt ID: 1142 SW 70th Ave

PRESTO!
Trace #: 745702
Reference #: 15005605
Act. #: XXXXXXXXXXXXXXXX
Purchase: Mastercard
Amount: \$4.99
Auth #: 00156P

CREDIT CARD	00156P
XXXXXXXXXX41010	MasterCard
Entry Method:	Chip/Pean
Node:	Issuer

Your cashier was Self-Checkout Lane 1
05/01/2026 5:22 51142 E174 40000000

Join the Publix team!
Apply today at apply.publix.jobs
We're an equal opportunity employer.

Publix Super Markets, Inc.



Advance Auto Parts

Service is our best part.

Store # 09327
3813 Land O' Lakes
Land O' Lakes FL 34639 (813) 929-9330
05/19/25 11:53 PM 04 TRN4 5406 Jessica J.

ITEM	QTY	PRICE	TOTAL
BRAIN PLG-1/4SNPLCKBRS 18821	1	\$5.99	\$5.99
BRAIN PLG-1 1/4SNPBRS 18871	1	\$6.99	\$6.99
Sub Total:			\$12.98
Tax			\$0.91
Total			\$13.89
Cash			\$20.00
CHANGE			\$6.11

Get \$5 off your next \$20 purchase
when you sign up for Advance Rewards.
Text 510.987.7733 to join today.
500 points = \$5 Reward

CUSTOMER

22RTP12wZa1107



YOU COULD WIN A \$200 GIFT CARD!

Tell us about your visit & see official
rules and how to enter without purchase!

advanceparts.com/survey

Enter code: 932704 06406 6124

Ends 12/31/2025. No Purchase Necessary.

JOIN OUR TEAM! NOW HIRING!

visit advanceparts.com/jobs

Buy Online - Pick Up Today at
www.advanceparts.com

Store: 9327

Advance Auto Parts

Page: 1

Date: 5/05/2026

Time: 14:07

Customer Transaction Reprint

Customer Name:		
Customer #:	0	Register: 4
Tx #:	5414	Drawer: 1
Date:	05/04/2026	TM: 942804
		SalesPerson 1: 273124
		SalesPerson 2: 0
		SalesPerson 3: 0

SKU	Description	Quantity	Price	Extended
50016078	DRAN FLG-1 1/4SNPB	-1	6.99	-6.99
			Total Due:	-7.48
	TAX 7 @	1	-0.49	-0.49
			Total Due:	-7.48
	Cash		Total Due:	-7.48
			Total Due:	-7.48

Transaction Comments:

5/11/2026 09:14:30
Order Number: 2805690
Circle K 2787575
7767 Land O'Lakes Bl
Land O'LakFL 34630
(813) 929-8798
Term: 2787575_SPMI
Appr: 3587411784-
UNL-REG
PUMP No. 11
Gallons 3.319
PRICE/G \$4.519
TOTAL FUEL \$15.80
TOTAL SALE \$15.00
Generic Mobile
XXXXXXXXXXXXXXXXXX
Cloud

05/11/2026 09:12:58

I agree to pay the
above Total Amount
according to Card
Issuer Agreement.

THANK YOU
HAVE A NICE DAY

Publix

Publix Super Market
2000 South 11th Street
Tomball, TX 77375
Phone: (281) 296-1391



142 500 000 001

P.B.

BANKING		
2.96	2.96	1.94
		1.34
		0.00
		1.34
Cash		2.00
		70.00

2000.00 1.00 *00.00 (01)

Van - 2000.00 (01)

2000.00 1.00 *00.00 (01)

2000.00 1.00 *00.00 (01)
Apply terms of agreement if job
is to be used as a contract or order.

Publix Super Markets, Inc.

STATE OF FLORIDA
DEPARTMENT OF HEALTH
Operating Permit



51-60-00549

51-BID-7815607

Swimming Pools - Public Pool > 25000 Gallons

Issued To: Wilderness Lake Preserve Fitness Pool
21320 Wilderness Lake Drive
Land O' Lakes, FL 34639

County: Pasco
Amount Paid: \$280.00
Date Paid: 05/14/2025
Issue Date: 07/01/2025

Permit Expires On: 06/30/2026

Mail To: Attention: Vesta District Services
The Preserve At Wilderness Lake Cdd
250 International Parkway, Suite 208
Lake Mary, FL 32746

Issued By:
Department of Health in Pasco County
7509 State Road 52
Hudson, FL 34667

(352) 521-1450 ext. 3

Owner: The Preserve At Wilderness Lake Cdd

Pool Volume (gallons): 127,800 Bathing Load: 75 Flow Rate (gpm): 3/5 Night Swimming: No
Variance Conditions (if applicable):

Original Customer: Wilderness Lake Preserve Fitness Pool (NON-TRANSFERABLE)

DISPLAY CERTIFICATE IN A CONSPICUOUS PLACE

STATE OF FLORIDA
DEPARTMENT OF HEALTH
Operating Permit



51-60-00549

51-BID-7815807

Swimming Pools - Public Pool > 25000 Gallons

Issued To: Wilderness Lake Preserve Fitness Pool
21320 Wilderness Lake Drive
Land O' Lakes, FL 34639

County: Pasco
Amount Paid: \$280.00
Date Paid: 05/14/2025
Issue Date: 07/01/2025

Permit Expires On: 06/30/2026

Mail To: Attention: Vesta District Services
The Preserve At Wilderness Lake Cdd
250 International Parkway, Suite 208
Lake Mary, FL 32746

Issued By:
Department of Health in Pasco County
7509 State Road 52 Suite 150
Hudson, FL 34667

(352) 521-1450 ext. 3

Owner: The Preserve At Wilderness Lake Cdd

STATE OF FLORIDA
DEPARTMENT OF HEALTH
Operating Permit



51-60-00550

51-BID-7815608

Swimming Pools - Public Pool > 25000 Gallons

Issued To: Wilderness Lake Preserve Pool 2
21320 Wilderness Lake Boulevard
Land O' Lakes, FL 34639

County: **Pasco**
Amount Paid: \$280.00
Date Paid: 05/14/2025
Issue Date: 07/01/2025

Permit Expires On: 06/30/2026

Mail To: Attention: Vesta District Services
The Preserve At Wilderness Lake CDD
250 International Parkway, Suite 208
Lake Mary, FL 32746

Issued By:
Department of Health in Pasco County
7509 State Road 52
Hudson, FL 34667

(352) 521-1450 ext. 3

Owner: The Preserve At Wilderness Lake CDD

Pool Volume (gallons): 74,500 Bathing Load: 49 Flow Rate (gpm): 245 Night Swimming: No
Variance Conditions (If applicable):

Original Customer: Wilderness Lake Preserve Pool 2 (NON-TRANSFERABLE)

DISPLAY CERTIFICATE IN A CONSPICUOUS PLACE

STATE OF FLORIDA
DEPARTMENT OF HEALTH
Operating Permit



51-60-00550

51-BID-7815608

Swimming Pools - Public Pool > 25000 Gallons

Issued To: Wilderness Lake Preserve Pool 2
21320 Wilderness Lake Boulevard
Land O' Lakes, FL 34639

County: **Pasco**
Amount Paid: \$280.00
Date Paid: 05/14/2025
Issue Date: 07/01/2025

Permit Expires On: 06/30/2026

Mail To: Attention: Vesta District Services
The Preserve At Wilderness Lake CDD
250 International Parkway, Suite 208
Lake Mary, FL 32746

Issued By:
Department of Health in Pasco County
7509 State Road 52
Hudson, FL 34667

(352) 521-1450 ext. 3

Owner: The Preserve At Wilderness Lake CDD



STATE OF FLORIDA
DEPARTMENT OF HEALTH
Operating Permit

51-60-00551

51-BID-7815910

Swimming Pools - Spa-Type Pools

Issued To: Wilderness Lake Preserve Spa
21320 Wilderness Lake Boulevard
Land O' Lakes, FL 34639

County: Pasco
Amount Paid: \$145.00
Date Paid: 05/14/2025
Issue Date: 07/01/2025

Permit Expires On: 06/30/2026

Mail To: Attention: Vesta District Services
The Preserve At Wilderness Lake CDD
250 International Parkway, Suite 208
Lake Mary, FL 32746

Issued By:
Department of Health in Pasco County
7509 State Road 52
Hudson, FL 34667

(352) 521-1450 ext. 3

Owner: The Preserve At Wilderness Lake CDD

Pool Volume (gallons): 1,250 Bathing Load: 8 Flow Rate (gpm): 50 Night Swimming: No
Variance Conditions (if applicable):

Original Customer: Wilderness Lake Preserve Spa (NON-TRANSFERABLE)

DISPLAY CERTIFICATE IN A CONSPICUOUS PLACE



STATE OF FLORIDA
DEPARTMENT OF HEALTH
Operating Permit

51-60-00551

51-BID-7815910

Swimming Pools - Spa-Type Pools

Issued To: Wilderness Lake Preserve Spa
21320 Wilderness Lake Boulevard
Land O' Lakes, FL 34639

County: Pasco
Amount Paid: \$145.00
Date Paid: 05/14/2025
Issue Date: 07/01/2025

Permit Expires On: 06/30/2026

Mail To: Attention: Vesta District Services
The Preserve At Wilderness Lake CDD
250 International Parkway, Suite 208
Lake Mary, FL 32746

Issued By:
Department of Health in Pasco County
7509 State Road 52
Hudson, FL 34667

(352) 521-1450 ext. 3

Owner: The Preserve At Wilderness Lake CDD



STATE OF FLORIDA
DEPARTMENT OF HEALTH
Operating Permit

51-60-00552

51-BID-7815999

Swimming Pools - Water Activity

Issued To: Wilderness Lake Preserve Interactive Water Feature
21320 Wilderness Lake Boulevard
Land O' Lakes, FL 34639

County: Pasco
Amount Paid: \$145.00
Date Paid: 05/14/2025
Issue Date: 07/01/2025

Permit Expires On: 06/30/2026

Mail To: Attention: Vesta District Services
The Preserve At Wilderness Lake CDD
250 International Parkway, Suite 208
Lake Mary, FL 32746

Issued By:
Department of Health in Pasco County
7509 State Road 52
Hudson, FL 34667
(352) 521-1450 ext. 3

Owner: The Preserve At Wilderness Lake CDD

Pool Volume (gallons): 256 Bathing Load: 38 Flow Rate (gpm): 25 Night Swimming: No
Variance Conditions (if applicable):

Original Customer: Wilderness Lake Preserve Interactive Water Feature (NON-TRANSFERABLE)

DISPLAY CERTIFICATE IN A CONSPICUOUS PLACE



STATE OF FLORIDA
DEPARTMENT OF HEALTH
Operating Permit

51-60-00552

51-BID-7815999

Swimming Pools - Water Activity

Issued To: Wilderness Lake Preserve Interactive Water Feature
21320 Wilderness Lake Boulevard
Land O' Lakes, FL 34639

County: Pasco
Amount Paid: \$145.00
Date Paid: 05/14/2025
Issue Date: 07/01/2025

Permit Expires On: 06/30/2026

Mail To: Attention: Vesta District Services
The Preserve At Wilderness Lake CDD
250 International Parkway, Suite 208
Lake Mary, FL 32746

Issued By:
Department of Health in Pasco County
7509 State Road 52
Hudson, FL 34667
(352) 521-1450 ext. 3

Owner: The Preserve At Wilderness Lake CDD



WILDERNESS LAKES Account Number:
813-996-0570-060723-5
PIN:
8786

Billing Date:
May 07, 2026
Billing Period:
May 07 - Jun 06, 2026

Hi WILDERNESS LAKES,

Thank-you for choosing Frontier, a Verizon Company. Have questions about your bill? Visit us at frontier.com/billing to learn more.

Bill history

Previous balance	\$450.69
Payment received by May 07, thank you	-\$450.69

Service summary

	Previous month	Current month
Bundle	\$407.14	\$407.14
Other	\$4.50	\$4.50
Taxes and Fees	\$39.05	\$39.05
Total services	\$450.69	\$450.69
Total balance		\$450.69

Total balance
\$450.69
Auto Pay is scheduled
Jun 01



Manage your account, payments, and services anytime, anywhere with the MyFrontier app. Download your free app today. To learn more visit frontier.com/myfrontierapp

Earn more. Get started with a business referral and earn up to \$325 per referral. Learn more: <https://www.businessreferralrewards.com>



P.O. Box 211579
Eagan, MN 55121-2879

6790 0107 DY RP 07 05082026 NNNNNN 01 006768 0032

WILDERNESS LAKES
250 INTERNATIONAL PKWY STE 208
LAKE MARY FL 32746-5062

You are all set with Auto Pay! To review your account, go to frontier.com or the MyFrontier app.



920002&139960570060723000000000000000450695



WILDERNESS LAKES Account Number:
813-996-0570-060723-5

Billing Date:
May 07, 2026

PIN:
8786

Billing Period:
May 07 - Jun 06, 2026

Don't let an unexpected outage stop your business. Get Frontier Internet Backup to keep your critical systems running. Visit: business.frontier.com/internet-backup



Bundle

Monthly Charges

05.07-06.06	Business Fiber Internet 500	\$49.99
	1 Usable Static IP Address	\$20.00
	Auto Pay Discount	-\$5.00
	OneVoice Nationwide	\$69.99
	OneVoice Access Line	
	OneVoice Features	
	OneVoice Long Distance Intra	
	Multi-Line Federal Subscriber Line Charge	\$9.20
	Access Recovery Charge Multi-Line Business	\$3.00
	FiberOptic TV - Business Preferred Public	\$204.99
	Sports/Broadcast TV Fee	\$29.99
(2)	Digital Adapter	\$13.98
	TV Standard Set-Top Box	\$11.00

Bundle Total **\$407.14**

If your bill reflects that you owe a Balance Forward, you must make a payment immediately in order to avoid collection activities. You must pay a minimum of \$101.00 by your due date to avoid disconnection of your local service. All other charges should be paid by your due date to keep your account current.

Future delivery of Frontier print directories may be reduced or eliminated in certain areas. You may access a digital version at www.therealyellowpages.com/ or <https://frontierwhitepages.dirxion.com/>. To receive a printed copy of your local directory, where available, at no charge call 1-844-339-6334. You can opt out of a printed directory by visiting www.yellowpagesoptout.com.



Other Charges

Monthly Charges

05.07-06.06	Printed Bill Fee	\$4.50
-------------	------------------	--------

Other Charges Total **\$4.50**

If you have a question or concern about Closed Captioning on any program, please call the Frontier Center for Customers with Disabilities at 1-877-462-6606 or email Video.Closed.Captioning@ftr.com. Written correspondence can be faxed to 1-805-262-0728, or mailed to Frontier Communications, 2560 Teller Road, Thousand Oaks, CA 91320, Attn: Kate Card. DO NOT mail payment to this address.

For up-to-date channel information please visit: <http://frontier.com/channelupdates>

Customer Proprietary Network Information (CPNI) Notice - CPNI is information made available to us solely by virtue of our relationship with you that relates to the type, quantity, destination, technical configuration, location, and amount of use of the telecommunications and interconnected VoIP services you purchase from us, as well as related billing information. The protection of your information is important to us, and you have a right, and we have a duty, under federal law, to protect the confidentiality of your CPNI.

We may use and share your CPNI among our affiliates and agents to offer you



Taxes and Fees

FCA Long Distance - Federal USF Surcharge	\$4.81
Federal USF Recovery Charge	\$4.51
Federal Excise Tax	\$0.37

Federal Taxes **\$9.69**

FL State Communications Services Tax	\$4.49
County Communications Services Tax	\$2.23
FL State Gross Receipts Tax	\$1.77
Pasco County 911 Surcharge	\$0.40
FL State Gross Receipts Tax	\$0.15
FL Telecommunications Relay Service	\$0.08

State Taxes **\$9.12**

FL Video Communications Service Tax	\$11.57
County Video Communications Services Tax	\$5.73
FL State Sales Tax	\$1.50
FL State Gross Receipts Tax - Video	\$0.71
FL State Gross Receipts Tax	\$0.35
County Sales Tax	\$0.25
FCC Regulatory Recovery Fee	\$0.13

Video **\$20.24**

Taxes and Fees Total **\$39.05**



WILDERNESS LAKES

Account Number:

813-996-0570-060723-5

Billing Date:

May 07, 2026

PIN:

8786

Billing Period:

May 07 - Jun 06, 2026

Frontier Bundled Video Service

Total Video Programming Charges

	FiberOptic TV - Business Preferred Public	\$204.99
	Sports/Broadcast TV Fee	\$29.99
Total		\$234.98





April 2026 Statement 03/10/2026 - 04/08/2026
 PWL CDD (CPN 002583416)

Elan Financial Services (1-866-552-8855

Transactions		DOBSON, ELLEN		Credit Limit \$10000	
Post Date	Trans Date	Ref #	Transaction Description	Amount	Notation
03/30	03/27	7173	PUBL X #006 WESLEY CHAPEL FL	\$24.34	1180190
03/30	03/27	7859	SAMSCLUB #4852 WESLEY CHAPEL FL 1180180-199.64	\$203.04	1180210-65.40
03/30	03/27	6726	AMAZON MKTFL*RS7EU7041 Amzn.com/bill WA 1180150-45.47	\$55.48	1180260-9.99
03/30	03/28	6869	AMAZON MKTFL*BC4108NU2 Amzn.com/bill WA	\$22.99	1180060
04/01	03/31	8696	PUBLIX #877 LAND O LAKES FL	\$36.53	1180210
04/01	03/31	8331	DOLLAR-GENERAL #8624 LAND O LAKES FL	\$4.55	1180040
04/02	04/01	6708	PUBLIX #877 LAND O LAKES FL	\$21.11	1180150
04/02	04/01	5182	CIRCLE K # D7641 LAND O LAKES FL	\$46.30	1180040
04/02	04/01	5866	LOWES #02238* LUTZ FL	\$175.00	1180040
04/02	04/02	0499	AMAZON MKTFL*FG6SA2C80 Amzn.com/bill WA	\$15.98	1180190
04/03	04/01	8662	MARCO'S PIZZA 9134 LAND O LAKES FL	\$65.45	1180210
04/03	04/02	0354	AMAZON MKTFL*BG33IS2W1 Amzn.com/bill WA	\$389.00	1180230
04/06	04/05	5334	PUBLIX #877 LAND O LAKES FL	\$16.95	1180210
04/06	04/05	5417	PUBLIX #1142 LAND O LAKES FL	\$189.88	1180210
04/06	04/05	3086	SAMSCLUB #4852 WESLEY CHAPEL FL 1180210-32.48	\$67.95	1180180-32.48
04/06	04/03	0082	SAMSCLUB #4652 WESLEY CHAPEL FL 1180180-169.10	\$470.45	1180150-18.98
04/06	04/03	8287	15*BOUNCE LOT INFLA 513-995-2935 FL 1180210-288.41	\$249.80	1180210
04/07	04/07	8089	Pet Supplies Plus 4011 Land LAKES FL	\$19.98	1180190
04/08	04/07	0653	PUBLIX #877 LAND O LAKES FL	\$22.04	1180190
04/08	04/07	7629	Amazon.com*B74YLDUW2 Amzn.com/bill WA	\$53.82	1180180
Total for Account ##### 8858				\$3,881.14	

Transactions		BILLING ACCOUNT ACTIVITY			
Post Date	Trans Date	Ref #	Transaction Description	Amount	Notation
Payments and Other Credits					
04/06	04/06	MTG	PAYMENT THANK YOU	\$4,777.56CR	
Total for Account ##### 8836				\$4,777.56CR	

2026 Totals Year-to-Date	
Total Fees Charged in 2026	\$0.00
Total Interest Charged in 2026	\$0.00



Interest Charge Calculation

Your Annual Percentage Rate (APR) is the annual interest rate on your account.

**APR for current and future transactions

Balance Type	Balance By Type	Balance Subject to Interest Rate	Variable	Interest Charge	Annual Percentage Rate	Expires with Statement
**BALANCE TRANSFER	\$0.00	\$0.00		\$0.00	0.00%	
**PURCHASES	\$3,281.14	\$0.00		\$0.00	0.00%	
**ADVANCES	\$0.00	\$0.00		\$0.00	0.00%	

Contact Us

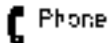

Phone
 Voice: 1-866-552-8855
 TDD: 1-866-352-6455
 Fax: 1-866-807-9053



Questions
 Elan Financial Services
 P.O. Box 6353
 Fargo, ND 58125-6353



Mail payment coupon with a check

Elan Financial Services
 P.O. Box 790408
 St. Louis, MO 63179-0408



Online

myaccountaccess.com

UNIVERSITY MICROFILMS INTERNATIONAL, 300 N ZEEB RD, ANN ARBOR MI 48106-1500

② Wilson & ②

Receipt Attached

The Preserve at Wilderness Lake CDD
Credit Card Memo Form

Credit Card Charge _____ Charge Date 3/18/2010

Date of Occurrence	Vendor Name	Amount	General Ledger Code & Purpose
<u>3/18/2010</u>	<u>WILSON</u>	<u>\$4.99</u>	<u>1180190</u>

Notes: _____

Hello Tish,

You ordered the item below, but the package is being returned to us by the carrier. We've issued your refund.

You can find the list of possible reasons why the package is being returned to us as undelivered [here](#).

[View return & refund status](#)

Return summary

Refund subtotal	\$4.99
Total refund*	\$4.99

Refund will appear on your Visa in 3-5 business days.

Item(s) in your return request



[Begeterday Thermometer and Humidity...](#)

Quantity: 1

Order # 114-6698568-8686642

(*) Rodgers (*)

Receipt Attached

The Preserve at Wridgers Lake CDD
Credit Card Memo Form

Credit Card Charge _____ Charge Date 3/15/2016

Date of Occurrence	Vendor Name	Amount	General Ledger Code & Purpose
<u>3/15/2016</u>	<u>WYNK 2016</u>	<u>\$-32.14</u>	<u>11805 PD</u>

Notes: _____

Return summary

Refund subtotal	\$32.89
Total refund*	\$32.89

Refund will appear on your Visa in 3-5 business days

Item(s) in your return request



Takis 18 pc / 1 oz Variety Pack...

Quantity: 2

Order # 114-6698568-8686642



Kaytee Food from The Wild Natural Pet

Quantity: 1

Order # 114-6698568-8686642

Receipts Attached

The Preserve at Wilderness Lake CDD
Credit Card Memo Form

Credit Card Charge

March 11, 2020
Charge Date

Date of Occurrence	Vendor Name	Amount	General Ledger Code & Purpose
3/11/20	Tampa Bay Inn	\$70.00	18000 Average State Ad

Notes:

Tampa Bay Times

tampabay.com

Order Confirmation and Receipt

3/11/2016

Ad Order Number

81476

Sales Rep

Cindy Pickett

Order Date

1/14/17

Order Source

Customer

WILDERNESS LAKE PREMIER

Customer Account

1066206

Customer Address

21120 WILDERNESS LAKE
LAND O LAKES, FL 34627

Customer Phone

8139952437

Payor Customer

WILDERNESS LAKE PREMIER

Payor Account

7386206

Payor Address

21120 WILDERNESS LAKE
LAND O LAKES, FL 34627

Payor Phone

8139952437

PO Number

Ordered By

Customer Fax

Customer Email

261444@vestapropertynetwork.com

Telephone

C

Altday(s)

0

Invoice Type

Community Garage Sale

Ad Order Notes

Net Amount

\$70.00

Tax Amount

\$0.00

Total Amount

\$70.00

Payment Method

Credit Card

Payment Amount

\$70.00

Amount Due

\$0.00

Receipt Attached

The Preserve at Wilderness Lake CDD
Credit Card Memo Form

Credit Card Charge

March 12, 2026
Charge Date

Date of Occurrence	Vendor Name	Amount	General Ledger Code & Purpose
3/12/26	Wilderness Lake	\$55.91	1180000

Notes:

3/12/2026 1:58:33
 Order Number: 1491547
 Card No: 2707575
 7767 Land O' Lakes Blvd
 Land O' Lakes, FL 34638
 (813) 929-8798
 Term: 132
 Appr: 012135
 LML-REG
 LMP No. 00
 all one 14.755
 P1CF/G \$3,749
 TOTAL PURL \$55.91
 TOTAL SALE \$55.91
 SALE
 VISA
 Card Num : (R)
 XXXXXXXXXXXXXXX853
 ON FACE LOSS
 USD\$ 55.91

VISA CREDIT
 ID: A98080963218-6
 TVR: 00030E030E
 DAD: XXXXXXXXXXXXXXX
 TSI: 09E0
 ANC: 09
 APDC:
 EA2E1EGLFB8RE0193

3/12/2026 1:53:33

I agree to pay the above Total Amount according to Card Issuer Agreement.

THANK YOU
HAVE A NICE DAY

Receipt Attached

The Preserve at Wilkewitsess Lake CDD
Credit Card Memo Form

Credit Card Charge

3/14/2016
Charge Date

Date of Occurrence	Vendor Name	Amount	General Ledger Code & Purpose
3/14/2016	Amazon	\$20.99	452050

Notes:

Order Summary

Order placed March 11, 2025 Order # 114-1510270-3018666

Ship to

The Preserve at Wilderness Lake LDD
21520 WILDERNESS LAKE BLVD
LAND O LAKES, FL 34617-7879
United States

Payment method

Visa ending in 8858
[View related transactions](#)

Order Summary

Item(s) Subtotal:	\$80.99
Shipping & Handling:	\$0.00
Total before tax:	\$80.99
Estimated tax to be collected:	\$0.00
Grand Total:	\$80.99

Delivered March 16



Peak Pursuit 65L / 17Gal. Round Commercial Trash Can, Heavy Duty Tall Open Top Garbage Can, Fingerprint-Proof Large Capacity Stainless Steel Waste Bin for Outdoor, Commercial Use
Sold by Amazon.com
Shipped by UPS
Return window closes on April 16, 2025
\$80.99

[Back to top](#)

[Conditions of Use](#) [Privacy Notice](#) [Consumer Health Data Privacy Disclosure](#) [Your Ads Privacy Choices](#)
© 1996-2025 Amazon.com, Inc. or its affiliates

Receipt Attached

The Preserve at Wilderness Lake CDD
Credit Card Memo Form

Credit Card Charge

3/11/26
Charge Date

Date of Occurrence	Vendor Name	Amount	General Ledger Code & Purpose
3/11/26	Amazon	\$ 24.52	1180190 - \$ 24.04
			1180190 - \$ 27.88

Notes:

Order Summary

Order placed March 11, 2026 Order # 114-6688568-8636542

<p>Ship to The Preserve at Wilderness Lake FPO 21320 WILDERNESS LAKE BLVD LAND O LAKES, FL 34637-7879 United States</p>	<p>Payment method Visa ending in 8858 View related transactions</p>	<p>Order Summary</p> <table border="0"> <tr><td>Item(s) Subtotal:</td><td>\$84.52</td></tr> <tr><td>Shipping & Handling:</td><td>\$2.99</td></tr> <tr><td>Free Shipping:</td><td>-\$2.99</td></tr> <tr><td>Total before tax:</td><td>\$84.52</td></tr> <tr><td>Estimated tax to be collected:</td><td>\$0.00</td></tr> <tr><td>Grand Total:</td><td>\$84.52</td></tr> <tr><td>Refund Total:</td><td>\$37.88</td></tr> </table>	Item(s) Subtotal:	\$84.52	Shipping & Handling:	\$2.99	Free Shipping:	-\$2.99	Total before tax:	\$84.52	Estimated tax to be collected:	\$0.00	Grand Total:	\$84.52	Refund Total:	\$37.88
Item(s) Subtotal:	\$84.52															
Shipping & Handling:	\$2.99															
Free Shipping:	-\$2.99															
Total before tax:	\$84.52															
Estimated tax to be collected:	\$0.00															
Grand Total:	\$84.52															
Refund Total:	\$37.88															

Delivered March 12

Your package was left near the front door or porch.

GS



Miss Vickie's Kettle Cooked Potato Chips, Variety Pack, 1.375 Ounce (Pack of 28)
Sold by: Amazon.com
Supplied by: Other
Return window closed on April 11, 2026
\$19.75

Refund issued

A refund will appear on your original payment method in 2-4 business days.

Why is a refund being issued?

ne



Begetoday Thermometer and Humidity Gauge for Hermit Crab - Ideal Supplies for Hermit Crab Tank
Sold by: Begetoday
\$4.99

ne



Kaytee Food from The Wild Natural Pet Guinea Pig Food, 4 Pound
Sold by: Amazon.com
Supplied by: Other
\$12.95

GS



Takis 18 pc / 1 Oz Variety Pack, Assorted Flavored Mixed Rolled Tortilla Chips - (5) Flavors: (3) Blue Heat, (2) Nitro, (4) Crunchy Tajitas
Sold by: Amazon.com
Supplied by: Other
\$9.87

Delivered March 12

Your package was left near the front door or porch.

GS



Amazon Day Ultimate Classic Snacks Package, Variety Assortment of Chips, Cookies, Crackers, & Nuts, 0.56 ounces (Pack of 40) (Packaging May Vary)
Sold by: Amazon.com
Supplied by: Other
Return window closed on April 11, 2026
\$25.91

[Back to top](#)

Receipt Attached

The Preserve at Wildemere Lake CDD
Credit Card Memo Form

Credit Card Charge

3-13-20
Charge Date

Date of Occurrence	Vendor Name	Amount	General Ledger Code & Purpose
3-13-20	Publix	\$20.35	1180210 - groceries 2.85

Notes:

Publix

Collier Commons
2121 Collier Pkwy
Lake O Lakes, FL 32039
Store Manager: E. Hall
813-945-9819



0877 304 085 592

SHARON'S COOKIES	4.99	F
SHARON'S COOKIES	4.99	F
MT 3 OIL SPEARS	4.19	F
PUB MAYS 11.50L	3.19	F
PUBLIC RED POTATO	2.99	F
You Saved	3.00	
Order Total	20.35	
Sales Tax	0.00	
Grand Total	20.35	
Credit	Payment	20.35
Change	0.00	

Savings Summary
Special Price Savings 3.00

* Your Savings at Publix *
* 3.00 *

Receipt ID: 0877 304 085 592

PRESTO!
Trace #: 085575
Reference #: 1022060077
Acct #: XXXXXXXX118033
Purchase VISA
Amount: \$20.35
Auth #: 713155

Publix

Collier Owners
 2127 Collier Hwy
 and O Lakes, FL 34691-2126
 (813) 516-9819
 Store Manager: Matt Garrett

Produce	
\$2.49 x 3	7.47
Organic Bananas Shredded	2.99
cs 1lb Baby Spinach	1.49
7pkcs 5lb Rg Prnt Unart	6.71
1ctry Foam Anals 12ct	4.79
Publix Plasticware Spoons	3.59
Subtotal	30.12
Sales Tax 7% - 1	2.10
Total Tax	2.10
Total	34.32
Credit	34.32
Change	0.00
Tax Exempt	1.06

nc
 ps

Visa #8858 \$30.12
 Credit Card Purchase
 Auth/Trace: 703120/040731 Exp. Refd
 Reference: 009237647717
 0000000003010
 0106 180101

03/13/2016 10:00am
 Thank you for shopping at store 0077
 Your receipt today has been P...
 9406, 0104, 207

Click Publix members Save more
 Join today at publix.com/members
 Terms & conditions apply

Publix Super Markets, Inc.



0877 378 049 418

Notes:

Date of Occurrence	Vendor Name	Amount	General Ledger Code & Purpose
3/13/2016	Publix	\$30.12	1180190 - 214.95
			1180150 - 215.17

Receipt Attached

The Preserve at Wildemess Lake CDD
 Credit Card Memo Form

Credit Card Charge

Charge Date March 13, 2016

Receipt Attached

The Preserve at Wilderness Lake CDD
Credit Card Memo Form

Credit Card Charge

Charge Date

3-13-26

Date of Occurrence	Vendor Name	Amount	General Ledger Code & Purpose
3-13-26	Wilderness	\$185.97	1180210 - 24 District Sup Just

Notes:

Charge history



View the order charge history of

Visa ending in 8858

Final charges

All final charges are the actual amount that will be charged to your payment method. Final charges include all adjustments (such as returns) with a final date.



Mar 15, 2020



Final order charge
\$145.97

\$145.97

Temporary holds

Temporary holds are temporary charges that are placed on your card.



Mar 15, 2020



Order adjustment
We will debit your Visa card to process
your return.

-\$140.94

Mar 12, 2020



Temporary hold
\$146.91

\$146.91

Card (0/0 items)

Pickup and delivery options



Free pickup and delivery, Same Day
\$4.95 delivery fee

Free

Items

24 Month Supply (24 items)



\$17 each
24 Month Supply Pack for 24 Months - 24 Month Supply Pack (24 Month Supply)
Add to cart

Free **Low Stock** 1 1



\$16 each
24 Month Supply Pack for 24 Months - 24 Month Supply
Add to cart

Free **Out of Stock** 4 1

24 Month Supply (24 items)



\$17 each
24 Month Supply Pack for 24 Months - 24 Month Supply
Add to cart

Free **Out of Stock** 1 1



\$17 each
24 Month Supply Pack for 24 Months - 24 Month Supply
Add to cart

Free **Out of Stock** 1 1

24 Month Supply (24 items)



\$15 each
24 Month Supply Pack for 24 Months - 24 Month Supply
Add to cart

Free **Out of Stock** 4 1



\$18 each
24 Month Supply Pack for 24 Months - 24 Month Supply
Add to cart

Free **Out of Stock** 1 1

24 Month Supply (24 items)



Subtotal \$167.20

Taxes \$16.72

Estimated \$183.92

Shipping \$0.00

Delivery \$0.00

One Free Cash Back with Card (1)
Get \$100 Cash Back with Card
Add to cart



1750 Aspirin
 1.5L 1.5L Aspirin
 Price: 14.49
 Add to Cart
 Add to Cart
 Add to Cart
 Add to Cart

Remove **Aspirin** 4 0

1000 Aspirin



1100 Aspirin
 1000 Aspirin
 Price: 14.49
 Add to Cart
 Add to Cart
 Add to Cart

Remove **Aspirin** 1 0

1000 Aspirin



1400 Aspirin
 1000 Aspirin
 Price: 14.49
 Add to Cart
 Add to Cart

Remove **Aspirin** 1 1

1000 Aspirin



1100 Aspirin
 1000 Aspirin
 Price: 14.49
 Add to Cart
 Add to Cart

Remove **Aspirin** 2 0

1000 Aspirin



1400 Aspirin
 1000 Aspirin
 Price: 14.49
 Add to Cart
 Add to Cart

Remove **Aspirin** 1 0

1000 Aspirin



1100 Aspirin
 1000 Aspirin
 Price: 14.49
 Add to Cart
 Add to Cart

Remove **Aspirin** 6 1

1000 Aspirin



1400 Aspirin
 1000 Aspirin
 Price: 14.49
 Add to Cart
 Add to Cart

Remove **Aspirin** 1 0

1000 Aspirin



1400 Aspirin
 1000 Aspirin
 Price: 14.49
 Add to Cart
 Add to Cart



\$4.99 (reg. \$5.99)
 12.5 oz. (350g) Prego® Italian Sauce, 24-ounce
 Multipack (Pack of 4)
 + Add to cart
 + Add to list
 + Add to cart

Food & Drink

Don't forget your staples

Shopping From



+ Add

\$2.99 (reg. \$3.99)
 Prego® Italian Sauce, 24-ounce
 Multipack (Pack of 4)
 + Add to cart
 + Add to list
 + Add to cart

Shopping From



+ Add

\$3.99 (reg. \$4.99)
 Stouffer's® Italian Sauce for
 Spaghetti, 10.5-ounce
 Multipack (Pack of 4)
 + Add to cart
 + Add to list
 + Add to cart

Shopping From



+ Add

\$2.99 (reg. \$3.99)
 Prego® Italian Sauce, 24-ounce
 Multipack (Pack of 4)
 + Add to cart
 + Add to list
 + Add to cart

Here's what's hot with your order



+ Add

\$3.99 (reg. \$4.99)
 Prego® Italian Sauce, 24-ounce
 Multipack (Pack of 4)
 + Add to cart
 + Add to list
 + Add to cart

New with us



+ Add

\$2.99 (reg. \$3.99)
 Prego® Italian Sauce, 24-ounce
 Multipack (Pack of 4)
 + Add to cart
 + Add to list
 + Add to cart

New with us



+ Add

\$0.99 (reg. \$1.99)
 Prego® Italian Sauce, 24-ounce
 Multipack (Pack of 4)
 + Add to cart
 + Add to list
 + Add to cart

Check Us Out on Easter Day in Store



+ Add

\$4.99 (reg. \$5.99)
 Prego® Italian Sauce, 24-ounce
 Multipack (Pack of 4)
 + Add to cart
 + Add to list
 + Add to cart



+ Add

\$3.99 (reg. \$4.99)
 Stouffer's® Italian Sauce for
 Spaghetti, 10.5-ounce
 Multipack (Pack of 4)
 + Add to cart
 + Add to list
 + Add to cart

New with us



+ Add

\$2.99 (reg. \$3.99)
 Prego® Italian Sauce, 24-ounce
 Multipack (Pack of 4)
 + Add to cart
 + Add to list
 + Add to cart

Explore more for you

New with us

New with us

Receipt Attached

The Preserve at Willamette Lake CDD
Credit Card Memo Form

Credit Card Charge

3-14-26
Charge Date

Date of Occurrence	Vendor Name	Amount	General Ledger Code & Purpose
3-14-26	Lexus Lease	\$ 276.00	1180airb

Notes:



Hi Trish,

Your automatic payment has been processed. Your next automatic payment will be processed on 4/14/2026. You can visit your My Account portal to see transaction details.

[VIEW MY ACCOUNT](#)

Access the Extra Space Storage mobile app to view your transaction details or manage your account



If you have any questions regarding your account in general, please contact us

Thank you.

Your Extra Space Storage Team

YOUR RECEIPT

Transaction Number:	357383031
Payment Date:	03/14/2026
Unit:	184
Payment Total:	\$276.00

Next payment due on:	4/14/2026
-----------------------------	-----------

YOUR FACILITY

Address	Phone
21338 Lake Patience Rd Land O Lakes, FL 34638	(813) 625-8459

[FAQ](#)

[CONTACT US](#)

Receipt Attached

The Preserves at Wildemess Lake CDD
Credit Card Memo Form

Credit Card Charge

3-17-26
Change Date

Date of Occurrence	Vendor Name	Amount	General Ledger Code & Purpose
3-17-26	Adobe	\$19.99	118070

Notes:



345 Park Avenue
San Jose CA 95110-2704
United States
Federal Tax ID: 07-0019522

ORIGINAL

Invoice Information

Invoice Number: 3355295447
Invoice Date: 17-MAR-2025
Payment Terms: Credit Card
Purchase Order: A8052302048930J5
Order Number: 7133017977
Customer Number: 1279161500
Currency: USD

Billed To

Ellen Dobson
FL 32746

INVOICE

Item Details

Service Term: 17-MAR-2025 to 16-APR-2025

PRODUCT NUMBER	PRODUCT DESCRIPTION	QUANTITY UNIT	UNIT PRICE	NET AMOUNT	TAX RATE	TAXES	TOTAL
33000066	Acrobat Pro	1 EA	19.99	19.99	100%	0.00	19.99

Invoice Total

NET AMOUNT (USD) 19.99
TAXES (SEE DETAILS FOR RATES) 0.00

GRAND TOTAL (USD) 19.99

Comments:

Billing Contact

<https://helpx.adobe.com/contact.html>

Thank you for your business!

Publix

Collier Centers
 7071 Collier Pkwy
 Fort Myers, FL 34639
 Store Manager: Lillian
 813 948-9819

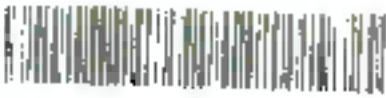

0677 008 515 236

PEPPERS MINI SHEET	nc	5.99	F
WOLE FROST BAR		5.29	F
MIDDLE FROST BAR		5.29	F
Promotion	63	-5.29	F
ROUND BAR		5.75	F
ROUND BAR		5.75	F
Promotion		5.75	F
OLD PARSLEY 11A	nc	1.99	F
ROMAINE			
2 @ 2.49	nc	4.98	F
TAX EXEMPT			

Order Total	25.00
Grand Total	25.00
Credit	25.00
TAX FURNISH	0.77
Change	0.00

Savings Summary
 Special Price Savings 11.04

 Your Savings at Publix *
 11.04 *

Receipt ID: 0677 008 515 236

WASTO!
 Trace #: 512408
 Reference #: 1037879652
 Acct #: XXXXXX/XXXX6858
 Purchase VISA
 Amount: \$25.00

Receipt Attached

The Preserve at Wilderness Lake CDD
 Credit Card Memo Form

Credit Card Charge

Charge Date

3-18-26

Date of Occurrence	Vendor Name	Amount	General Ledger Code & Purpose
3-18-26	Publix	\$ 25.00	1180190 - \$13.76 1180180 - \$11.04

Notes:

Receipt Attached

The Preserve at Wilderness Lake CDD
Credit Card Memo Form

Credit Card Charge _____ Charge Date 3/18/26

Date of Occurrence	Vendor Name	Amount	General Ledger Code & Purpose
<u>3/18/26</u>	<u>Amazon</u>	<u>\$ 26.90</u>	<u>1180925</u>

Notes: _____

Order Summary

Order placed March 18, 2026 Order # 114-515157B-0009923

Ship to

The Preserve at Wilderness Lake CDD
21520 WILDERNESS LAKE BLVD
LAND O LAKES, FL 34637-7879
United States

Payment method

Visa ending in 8858

[View order transactions](#)

Order Summary

Item(s) Subtotal:	\$26.00
Shipping & Handling:	\$2.09
Free Shipping:	-\$2.99
Total before tax:	\$25.90
Estimated tax to be collected:	\$0.00
Grand Total:	\$25.90

Delivered March 18

Your package was left near the front door or porch.



Kaytee food from The Wild Natural Pet Guinea Pig Food, 4 Pound
Sold by: Amazon.com
Supplied by: Other
Return window closed on April 17, 2026
\$12.95

Delivered March 18

It was handed directly to a receptionist or someone at a front desk.



Kaytee Wafer Crib All Natural Timothy Hay for Pet Guinea Pigs, Rabbits & Other Small Animals, 60 Dinner
Sold by: Amazon.com
Supplied by: Other
Return window closed on April 7, 2026
\$1.95

[Back to top](#)

[Conditions of Use](#) [Privacy Notice](#) [Consumer Health Care Privacy Disclosure](#) [Your Ads Privacy Choices](#)
© 1996-2026, Amazon.com, Inc. or its affiliates

Receipt Attached

The Preserve at Wilderness Lake CDD
Credit Card Memo Form

Credit Card Charge

3/18/26
Charge Date

Date of Occurrence	Vendor Name	Amount	General Ledger Code & Purpose
3/18/26	Amazon	\$ 39.91	1180210 Exp Adm S

Notes:

Order Summary

Order placed March 18, 2026 Order # 114-3904191-0192246

Ship to

The Preserve at Wilderness Lake CDO
21523 WILDERNESS LAKE BLVD
LAND O LAKES, FL 34654-7679
United States

Payment method

Visa ending in 8958

[View related transactions](#)

Order Summary

Item(s) Subtotal:	\$59.91
Shipping & Handling:	\$2.99
Free Shipping:	-\$2.99
Total before tax:	\$59.91
Estimated tax to be collected:	\$0.00
Grand Total:	\$59.91

Delivered March 19

It was handed directly to a recipient or someone at a front desk.



ZMLM 165 Pcs Rainbow Smatch Paper Art Notes - Easter Crafts for Kids Ages 4-8, Easter Basket Stuffers for Girls & Boys, Classroom Prizes, Student Gifts School Activity

Sold by: ZMLM Direct

Return window closed on April 17, 2026
\$8.94



Woyree Easter Crafts for Kids, 36 Pcs DIY Wooden Magnets Art Craft Supplies Painting Kit for Boys Girls Ages 4-8-12 Birthday Easter Activities Toys Gifts Party Favors Basket Stuffers Bag Stuffers

Sold by: Woyree

Return window closed on April 17, 2026
\$11.00



ArtCreativity 1000+ Easter Stickers for Kids with 100 Stickers Sheets, Made in USA Assorted Vibrant Colors and Designs, Easter Basket Stuffers, Fillers Party Favors for Boys and Girls

Sold by: ArtCreativity

Return window closed on April 17, 2026
\$6.00

E.H.

[Back to top](#)

Receipt Attached

The Preserve at Wilderness Lake CDD
Credit Card Metro Form

Credit Card Charge

Charge Date

3/18/26

Date of Occurrence	Vendor Name	Amount	General Ledger Code & Purpose
3/18/26	Amazon	\$19.94	1160120

Notes:

Order Summary

Order placed March 18, 2025 Order #: 114-4196936-5762630

Ship to

The Preserve at Wilderness Lake CDD
21520 WILDERNESS LAKE BLVD
LAND O LAKES, FL 34637-7874
United States

Payment method

Visa ending in 9858
[view related transactions](#)

Order Summary

Item(s) Subtotal	\$19.94
Shipping & handling	\$2.39
Free Shipping	-\$2.39
Total before tax	\$19.94
Estimated tax to be collected	\$0.00
Grand Total	\$19.94

Delivered March 18

Your package was left near the front door or porch.



Takis 18 pc / 7.07 Oz Variety Pack, Assorted Flavored Mixed Rolled Tortilla Chips - (5) Fuego, (5) Blue Heat, (4) Nitro, (4) Crunchy Fajitas
Sold by Amazon.com
Shipped by Other
*Lithium battery inserted on April 17, 2026
\$4.99

[Back to top](#)

[Conditions of Use](#) [Privacy Notice](#) [Customer Health Data Privacy Disclosure](#) [Your ad Privacy Choices](#)
© 1996-2025, Amazon.com, Inc. or its affiliates.

Receipt Attached

The Preserve at Wilderness Lake CDD
Credit Card Memo Form

Credit Card Charge _____ Charge Date 3/18/26

Date of Occurrence	Vendor Name	Amount	General Ledger Code & Purpose
<u>3/18/26</u>	<u>Amazon</u>	<u>\$42.96</u>	<u>440200 Egg Dinner</u>

Notes: _____

Order Summary

Order placed March 18, 2026 Order # 114-1175896-8337021

Ship to

The Preserve at Wilderness Lake CDD
21320 WILDERNESS LAKE BLVD
LAND O LAKES, FL 34637-7879
United States

Payment method

VISA ending in 8858
[View related transactions](#)

Order Summary

Item(s) Subtotal:	\$42.96
Shipping & Handling:	\$0.00
Total before tax:	\$42.96
Estimated tax to be collected:	\$0.00
Grand Total:	\$42.96

Delivered March 19

Your package was left near the front door or porch



Newkirk Small Cellophane Bags, Clear Gift Treat Bags for Candy, Cake Pops, Goodies & Party Favors with 4" Ties 100PCS (4" x 6")
Sold by: Smalls

Return or replace from 8/6/24 through June 17, 2026
\$4.99



600 Pcs Easter Basket Stuffers for Kids Party Favors, Easter Fillers, Hinged Toys Bulk Easter Toys, Stacking Stuffers Birthday Gifts, Carnival Treasure Classroom Prizes Box, Pinata Fillers, Easter Egg Hunt
Sold by: Embury

Return window closed on April 18, 2026
\$18.99



SANNIX 656Pcs Easter Foam Stickers Set DIY Crafts Self Adhesive Eggs Bunny Chick Foam Stickers with Sticky Dots Crafts for Kids Easter Decoration's Party Favor Supplies
Sold by: SANNIX

Return window closed on April 18, 2026
\$17.99

S.T.

[Back to top](#)

[Conditions of Use](#) [Privacy Notice](#) [Consumer Health Data Privacy Disclosure](#) [Your Ads Privacy Choices](#)
© 1996-2026, Amazon.com, Inc. or its affiliates

Receipt Attached

The Preserve at Wadsworth Lake CDD
Credit Card Memo Form

Credit Card Charge

3-18-26
Charge Date

Date of Occurrence	Vendor Name	Amount	General Ledger Code & Purpose
3-17-26	Luns Kitchens	\$39.90	1180110

Notes:

Luna Roaches

You can see the items that have been sent to you and track your shipment below. Thanks for shopping with us.

Order No. 21671

Placed on Mar 16, 2026

Shipping to

Ellen Dobson
21320 Wilderness Lake Blvd
Land O' Lakes, Florida, 34637
United States
manager@wlpodge.com

Shipped Items



Subscription ONLY - 100 Medium
Discoid Roaches (1/2 - 3/4)
Hold for Pickup at Post Office? No
Add Food?: No

Qty: 1

\$39.90

Add Water Crystals?: No

If you selected "Hold for Pickup" please
add your Phone number here for
notification for Pickup..

Price: \$39.90

Subscription: Every 3 weeks until
canceled

Publix

Callier Coupons
 2121 Callier Pkwy
 Palm D Lakes, FL 34901 5700
 (813) 998-9819
 Store Manager: Elliott Elliott

2 Day W/ Smo (Th) Top 100 1 **65** 7.19
 Breakfast Cane Super Mugl F1 0.29
 Breakfast Cane Super Mugl F1 0.00
 You saved: \$3.29
 Donutlck Cookie Dipced F1 10.29
 Donutlck Cookie Dipced F1 0.00
 You saved: \$10.29
 H&M Sandwich Chocolate F1 6.09
 H&M Sandwich Chocolate F1 0.00
 You saved: \$6.09
 H&M Sandwich Chocolate F1 6.09
 H&M Sandwich Chocolate F1 0.00
 You saved: \$6.09
 Publix Mini Cinnamon Roll 11 15.99
 Publix Mini Choc Mocha Cookie 1 6.99
 Publix Mini Cookies 1 6.99

*Budget
 went
 shop*

Subtotal 69.92
 Sales Tax 0.00
 Total Tax 0.00
 Total 69.92
 Credit 69.92
 Change 0.00

Tax Exempt 3.41

SAVINGS: \$32.76

visa: +856 469.02
 Credit Card purchase
 Card Number: 7191*27042612
 Card Name: CHLO ROSS
 Reference: 002653041802
 0000000000000000
 VISA DEBIT

03/19/2026 00:27:11
 Thank you for shopping at store 0117/
 Your Cashier today was Sydney G.
 0117, 0114, 141

Notes:

Date of Occurrence	Vendor Name	Amount	General Ledger Code & Purpose
3-19-26	Publix	\$69.92	1180180 - \$39.95
			1180210 - \$29.97 Cr.

Receipt Attached

The Preserve at Whitestone Lake CDD
 Credit Card Memo Form

Credit Card Charge

Change Data

3-19-26

Receipt Attached

The Preserve at Wilderiness Lake CDD
Credit Card Memo Form

Credit Card Charge

3/11/26
Charge Date

Date of Occurrence	Vendor Name	Amount	General Ledger Code & Purpose
3/11/26	Amazon	\$91.64	1180040

Notes

Order Summary

Order placed: March 11, 2026 Order # : 14-4627214-0940268

Ship to	Payment method	Order Summary
The Preserve at Wilderness Lake CDC 21320 WILDERNESS LAKE BLVD LAND O LAKES, FL 34637-7879 United States	View related transactions Visa ending in 8950	Item(s) Subtotal: \$91.64 Shipping & Handling: \$0.00 Total before tax: \$91.64 Estimated tax to be collected: \$0.00 Grand Total: \$91.64

Delivered March 26

Your package was left near the front door or porch.



Frolab Advanced Antibacterial Clean & Smooth Liquid Hand Soap - 750 ML
 Sold by: SimplyPrima
 Shipped by: Otho
 Return window closed on April 25, 2026
 \$22.99

[Back to top](#)

[Conditions of use](#)
 [Privacy Notice](#)
 [Consumer Health Data Privacy Statement](#)
 [Your Ads Privacy Choices](#)
 © 1996-2026, Amazon.com, Inc. or its affiliates

Receipt Attached

The Preserve at Wilderness Lake CDD
Credit Card Memo Form

Credit Card Charge

3-25-26
Charge Date

Date of Occurrence	Vendor Name	Amount	General Ledger Code & Purpose
3-25-26	Bounce A Lot Infill	\$1,802.00	180210 - Spring Ricks

Notes:

Total \$333.04

Chula - 03/25/2026 12:37am Card on File Payment (8858) \$50.00

Due \$283.04

Invoice/Receipt #73859

Bounce A Lot Inflatables

1106 Sunset Lane

Lutz, FL 33549

813-996-2935 office

www.BounceALotInflatables.com

CustomerService@BounceALotInflatables.com

-We Rent Fun!



Bounce A Lot Inflatables & Events

1106 Sunset Lane (payments & main mailing address) **Important Information – Please Read Below!**

Lutz, FL 33549

813-996-2935

BounceALotInflatables.com

04/04/2026 12:00pm, 04/04/2026 02:00pm

Preserve at Wilderness Lake

Ellen - (Tish) Dobson

21320 Wilderness Lake Preserve Blvd.



Land O' Lakes, FL 34637

tdobson@vestapropertyservices.com

813 995-2437 //813-758-4841 Tish /

Order Created by: Patricia "Chula" Rebenack

Customer Comments:DELIVERY AFTER 7:00am Okay / Power available on site /

		Sat. Apr 4 12:00 → 2:00 pm	
	Tropical Animals Bouncer UNIT #123	\$127.00	x 1 = \$127.00
	*NEW* - Football Quarterback Challenge UNIT #345	\$157.00	x 1 = \$157.00

SubTotal		\$284.00
Perk Set Up - Yes - Event is at a PUBLIC / PRIVATE PARK / BUSINESS / APARTMENT location	\$20.00	\$304.00
Damage Waiver - Yes - I want to include the damage waiver	\$15.20	\$319.20
Fuel Cost - I understand	\$10.00	\$329.20
Travel Fee for 34637	\$9.00	\$338.20
Coupon: Freq Renter (-10%)	-	\$309.80
Tax Exempt	\$0.00	\$309.80

Total \$309.80

Chula - 03/25/2026 12:37pm Card on File Payment (8858) \$50.00 

Due \$259.80

Receipt Attached

The Preserve at Wilderness Lake CDD
Credit Card Memo Form

Credit Card Charge

3-25-26
Charge Date

Date of Occurrence	Vendor Name	Amount	General Ledger Code & Purpose
3-25-26	ORL-Dorman	\$2319	110150
	Go Dordwy.com LLC		

Notes:

Receipt

№ 4048121906

CONTACT US 24/7 1-480 605-887

DATE:
3/25/2026

CUSTOMER #:
22433699

BILL TO:
Sean Craft
21320 Wilderness Lake Blvd.,
Land O Lakes, Florida 34639,
United States
Wilderness Lake Preserve
+1 3522323238

PAYMENT
Visa **** 8858 \$23.19

Previous Balance \$23.19

Received Payment (\$23.19)

Balance Due (USD) 30.00

Term	Product	Amount
1 yr	ORG Domain Renewal wildernesslakecdd.org	\$22.99
	Subtotal	\$22.99
	Taxes	\$0.00
	Fees	\$0.00
	Total (USD)	\$23.19

REFERENCE

Taxes \$0.00

GoDaddy.com, LLC \$0.00

PET SUPPLIES PLUS.

21763 Village Lakes Shopping Center Dr
 Land O Lakes, FL 34631
 USA
 813 575-6738

Store# 4011 Date: 3/25/2016
 Receipt# 401101 Time: 09:04 PM
 Receipt ID: 4011113547764
 Operator ID: 431120
 Term Number: 2131000
 Key: 4. 41340223.402
 Terminal: 1011 0016

ITEM NAME	QTY	PRICE	TOTAL
PURV UV PROTECTANT ASPEN 13.1	1	\$15.98	\$15.98
750683144571			
Subtotal			\$15.98
Total tax			\$0.00
Total			\$15.98
Card	1160	0900	\$15.98

ALL INFORMATION HEREON IS UNCLASSIFIED EXCEPT WHERE SHOWN OTHERWISE

Receipt Attached

The Preserve at Wilderness Lake CDD
 Credit Card Memo Form

Credit Card Charge

Charge Date

3-25-26

Date of Occurrence	Vendor Name	Amount	General Ledger Code & Purpose
3-25-26	Pet Supplies Plus	\$15.98	480190

Notes:

Receipt Attached

The Preserve at Wilderness Lake CDD
Credit Card Memo Form

Credit Card Charge

3-25-26
Charge Date

Date of Occurrence	Vendor Name	Amount	General Ledger Code & Purpose
3-25-26	Tempe Bay Timber	\$112.40	110110

Notes:

Tampa Bay Times

tampabay.com

Order Confirmation and Receipt

30529124			
<u>Ad Order Number</u> 53176	<u>Customer</u> THE PRESERV AT WILDERNE	<u>Paper Customer</u> THE PRESERV AT WILDERNESS LAKE	<u>PO Number</u>
<u>Sales Rep</u> Dencie Bonet	<u>Customer Account</u> TR10421	<u>Paper Account</u> TR10421	<u>Ordered By</u> Jackie Leper
<u>Order Taken</u> ODONETT	<u>Customer Address</u> 250 International Pkwy Ste 208 Lake Mary, FL 32746-5002	<u>Paper Address</u> 250 International Pkwy Ste 208 Lake Mary, FL 32746-5002	<u>Customer Fax</u>
<u>Order Source</u>	<u>Customer Phone</u> 3212830102	<u>Paper Phone</u> 3212830102	<u>Customer Email</u> dhrnc12@webproperty-services.co m

Transship
n

Articles
1

Invoice Text
BO5 Meeting

Ad Order Notes

Net Amount
\$110.40

Tax Amount
\$0.00

Total Amount
\$110.40

Payment Method
Credit Card

Payment Amount
\$ 110.40

Amount Due
\$0.00

Tampa Bay Times

tampabay.com

THE PRESERVE AT WILDEMISS LAKE COMMUNITY DEVELOPMENT DISTRICT NOTICE OF BOARD OF SUPERVISORS REGULAR MEETING

Notice is hereby given that a regular meeting of the Board of Supervisors of The Preserve at Wildemiss Lake Community Development District (the "District") will be held on Friday, April 16, 2010, at 9:30 a.m. at The Preserve at Wildemiss Lake Lodge, located at 2122 Wildemiss Lake Boulevard, Wildemiss Lake, FL 34647. The purpose of the meeting is to discuss any topics presented to the Board for consideration.

Copies of the agenda may be obtained from the District Manager, West District Services, 150 International Parkway, Suite 200, Lake Mary, Florida 32746. Telephone: (321) 263-0100, Ext. 200.

The meeting is open to the public and will be conducted in accordance with the provisions of Florida law for community development districts. The meeting may be continued in progress without additional notice at a date, time, and place to be specified at the meeting. There may be occasions when staff and/or Supervisors may participate by telephone.

Pursuant to provisions of the American with Disabilities Act, 29 CFR 1630.18(a) requiring equal accommodations to individuals in this meeting, it is asked to advise the District Manager's office at least forty-eight (48) hours before the meeting by contacting the District Manager at (321) 263-0100, Ext. 200. If you are hearing or speech impaired, please contact our Florida Relay Service at (1-800) 352-8747 in contacting the District Manager's office.

A person who desires to appeal any decision made at the meeting, with respect to any matter considered at the meeting, is advised that a record of the proceedings is needed and that accordingly, the person may need to ensure that a verbatim record of the proceedings is made, including the testimony and evidence upon which the appeal is to be based.

The Preserve at Wildemiss Lake Community Development District
Tina Dolson, District Manager
(321) 263-0100, Ext. 200
April 1, 2010

10110

Receipt Attached

The Preserve at Wildemere Lake CDD
Credit Card Memo Form

Credit Card Charge

Charge Date

3-26-26

Date of Occurrence	Vendor Name	Amount	General Ledger Code & Purpose
3-26-26	Lowe's	\$91.04	1180-40

Notes:



LEARN MORE AT LOWES.COM/INTUNE/SRE/QR005

LOWE'S HOME CENTERS, LLC
1500 STATE RD SW
MARIETTA, GA 30067-1473 770.962.0000

SAIL

SALES TAX (7.00%) 6.37

SALES TAX (7.00%)	6.37
SALES TAX (7.00%)	6.37
SALES TAX (7.00%)	6.37
SALES TAX (7.00%)	6.37
SALES TAX (7.00%)	6.37
SALES TAX (7.00%)	6.37
SALES TAX (7.00%)	6.37
SALES TAX (7.00%)	6.37
SALES TAX (7.00%)	6.37
SALES TAX (7.00%)	6.37

SALES TAX (7.00%) 6.37
SALES TAX (7.00%) 6.37
SALES TAX (7.00%) 6.37
SALES TAX (7.00%) 6.37
SALES TAX (7.00%) 6.37
SALES TAX (7.00%) 6.37
SALES TAX (7.00%) 6.37
SALES TAX (7.00%) 6.37
SALES TAX (7.00%) 6.37
SALES TAX (7.00%) 6.37

SALES TAX (7.00%) 6.37
SALES TAX (7.00%) 6.37
SALES TAX (7.00%) 6.37
SALES TAX (7.00%) 6.37
SALES TAX (7.00%) 6.37
SALES TAX (7.00%) 6.37
SALES TAX (7.00%) 6.37
SALES TAX (7.00%) 6.37
SALES TAX (7.00%) 6.37
SALES TAX (7.00%) 6.37



© 2025 Lowe's Companies, Inc.

Receipt Attached

The Preserve at Wilderness Lake CDD
Credit Card Memo Form

Credit Card Charge

Charge Date 3/22/24

Date of Occurrence	Vendor Name	Amount	General Ledger Code & Purpose
3/21/24	Publix	\$24.34	1100190

Notes:



Stores of Mer...
1920 County Road SW
Nesley Chapel, FL 33544
Store Manager: Mike Barkat
813 994-4566



0005 050 076 247

MORNING			
7 6	2.69	5.38	F
GS ORG SHIRT/SHIRT 507		4.99	F
GR DKG BABY KALE		4.99	F
PEPPER MIN. SWEET		0.99	F
PLA CARROT SHRED		2.99	F
Order Total		24.34	
Sales Tax		0.00	
Grand Total		24.34	
Credit	Payment	24.34	
Change		0.00	

Receipt ID: 0005 050 076 247

PRESTO:
Trace #: 077900
Reference #: 1940475559
Auth #: 833XXXXXX80850
Purchase VISA
Amount: \$24.34
Auth #: 607284

CREDIT CARD PURCHASE
ADDITIONAL INFO: VISA GREET
Entry Method: Chip Read
Note: Issued

Your cashier has charged

03/22/2024 1.46 500.00 86-7 0247 153710

Join the Publix family!
Apply today at publix.jobs.
We're an equal opportunity employer.

Publix Super Markets, Inc.

Receipt Attached

The Preserve at Wilderness Lake COD
Credit Card Memo Form

Credit Card Charge

Charge Date

2/27/26

Date of Occurrence	Vendor Name	Amount	General Ledger Code & Purpose
2/27/26	Amazon	\$55.46	1180200 - \$55.46
			1180150 - \$45.47

Notes:

Order Summary

Order placed March 27, 2026 Order # 114-6613041-8024226

Ship to

The Preserve at Wilderness Lake CDD
71320 WILDERNESS LAKE BLVD
LAND O LAKES, FL 34657-7875
United States

Payment method

Visa ending in 8358

[View order transactions](#)

Order Summary

Item(s) Subtotal:	\$55.46
Shipping & Handling:	\$0.00
Total before tax:	\$55.46
Estimated tax to be collected:	\$0.00
Grand Total:	\$55.46

Delivered March 28

Package was left in a secure location



Franklin Sports x-40 Performance Outdoor Pickleballs - Usapa Approved (12 Pack)
Sold by: Amazon.com
Supplied by: Other
Returns or replace items: Eligible through April 27, 2026
\$29.48



LAO XUE Basketball Net Outdoor (7.36 oz) 12 Loops Professional Heavy Duty Basketball Net Replacement, All Weather Anti Whip, Suitable for Outdoor Standards 12 Loops Basketball Hoop
Sold by: LAO XUE
Returns or replace items: Eligible through April 27, 2026
\$9.59



Nestle Coffee mate Coffee Creamer Original, Liquid Creamer Singles, Non Dairy, No Refrigeration, 0.375 Fl oz tubs (Pack of 190)
Sold by: Amazon.com
Supplied by: Other
Returns or replace items: Eligible through April 27, 2026
\$15.99

RS

[Back to top](#)

Receipt Attached

The Preserve at Wilderness Lake CDD
Credit Card Memo Form

Credit Card Charge _____ Charge Date 3/29/26

Date of Occurrence	Vendor Name	Amount	General Ledger Code & Purpose
<u>3/29/26</u>	<u>Amazon</u>	<u>\$ 22.99</u>	<u>11500000</u>

Notes:

Order Summary

Order placed March 27, 2025 Order ID: 114-7070581-0128216

Ship to

The Preserve at Wilderness Lake CDD
21520 WILDERNESS LAKE BLVD
LAND O LAKES, FL 34637-7875
United States

Payment method

Visa ending in 0558

[View related transactions](#)

Order Summary

Item(s) Subtotal:	522.99
Shipping & Handling:	\$0.00
Total before tax:	522.99
Estimated tax to be collected:	\$0.00
Grand Total:	522.99

Delivered March 29

Package was left inside the residence's mailbox



EcoLab Advanced Antibacterial Clean & Smooth Liquid Hand Soap - 750 ML
Sold by Plus Products 560
Return to purchase item. Eligible through April 28, 2025.
\$22.99

[Back to top](#)

[Conditions of Use](#) [Privacy Notice](#) [Corporate Health Data Privacy Disclosure](#) [Your Ads Privacy Choices](#)
© 1996-2025, Amazon.com, Inc. or its affiliates

Publix

DeLler Cousins
 2121 Collins Pkwy
 Land O Lakes, FL 34624
 Store Manager: Elliott
 813-948-4819



0877 41R 517 3b1

R.S.

FOLGERS ARDHA SEAI 21.11 F
 FOLGERS ARDHA SEAI 21.11 F
 Promotion 21.11 F
 Order Total 21.11
 Sales Tax 0.00
 Grand Total 21.11
 Credit Paid 21.11
 Change 0.00

Buyings ~~Save~~ 2
 Special Price Savings 21.11

 Your Savings at Publix *
 21.11 *

Receipt In: 0877 41R 517 3b1

PRESTO:
 Trade #: 519774
 Reference #: 1333026276
 Acct #: XXXX XXXX XXXX 05
 Purchase VISA
 Amount: \$21.11
 Auth #: 701021

Receipt Attached

The Preserve at Wilderness Lake CDD
 Credit Card Memo Form

Credit Card Charge

4-1-26
 Change Date

Date of Occurrence	Vendor Name	Amount	General Ledger Code & Purpose
4-1-26	Publix	\$21.11	1180150

Notes:

Receipt Attached

The Preserve at Wildemere Lake CDD
Credit Card Memo Form

Credit Card Charge

Charge Date

4-1-26

Date of Occurrence	Vendor Name	Amount	General Ledger Code & Purpose
4-1-26	CIRCLE K	\$46.68	180000

Notes:

4/1/2025 11:58:3
 Order Number: 1271310
 Circle K 2707941
 4710 Lond T Lakes RI
 Lond 0 Lak FL 34839
 (813) 929-7822
 Term: 182
 Appr: 311065
 UNL-RFO
 P.W.P. No. 03
 Gallons 16.839
 PRICE/G \$4.230
 TOTAL FUEL \$70.63
 TOTAL SALE \$46.68
 SALE
 Visa
 Card Num: (R)
 XXXXXXXXXXXXXXX56
 Contact: (R)

USD\$ 46.68
 VISA CREDIT
 ID: A0800032531310
 CVV: 690625H300
 CMO: XXXXXXXXXXXXXXX
 CSI: 63ER
 ARC: 06
 REG:
 500492100E24406

4/31/2026 1:55:59
 I agree to pay the
 above Total Amount
 according to Card
 issuer Agreement.

THANK YOU
 HAVE A NICE DAY

Receipt Attached

The Preserve at Wilderness Lake CDD
Credit Card Memo Form

Credit Card Charge

4/1/26
Charge Date

Date of Occurrence	Vendor Name	Amount	General Ledger Code & Purpose
4/1/26	Amazon	\$15.98	1180190

Notes:

Order Summary

Order placed April 1, 2026 Order # 114-630-3596-1177931

Ship to

The Preserve at Wilderness Lake CDD
21320 WILDERNESS LAKE BLVD
LAND O LAKES, FL 34637-7879
United States

Payment method

Visa ending in 8958

[View related transactions](#)

Order Summary

Item(s) Subtotal:	\$15.98
Shipping & Handling:	\$0.00
Total before tax:	\$15.98
Customer tax to be collected:	\$0.00
Grand Total:	\$15.98

Delivered April 2

Your package was left near the front door or porch.



Reptile Water Dish Food Bowl for Bearded Dragon Tank Accessories, Reptile Rock Feeder for Tank & Park Corner Resin Terrarium Bowl for Leopard Gecko Hermit Crab Tortoise Snake, Black

Sold by Amazon

Return or replace now. Eligible through May 2, 2026
\$9.99



Reptile Thermometer and Humidity Gauge, 2PCS Digital Hygrometer Adhesive Reptile Terrarium Hygrometer, Bearded Dragon Tank Accessories, Pet Humidity Meter Supplies for Leopard Crested Gecko, Snake Lizard

Sold by Amazon

Return or replace now. Eligible through May 2, 2026
\$5.99

[Back to top](#)

[Conditions of Use](#) [Privacy Notice](#) [Consumer Health Data Privacy Notice](#) [Your Ads Privacy Choices](#)
© 1996-2025, Amazon.com, Inc. or its affiliates

Receipt Attached

The Preserve at Wilderness Lake CDD
Credit Card Memo Form

Credit Card Charge

Charge Date

4-1-26

Date of Occurrence	Vendor Name	Amount	General Ledger Code & Purpose
4-1-26	Marco's Pizza	65.46	1140200 Marco's Pizza

Notes:

Marco's Pizza
7808 1 and 0 Lakes Blvd
1 and 0 Lakes, FL 34638
(813) 843 3600

195

Phone Take-Out

DUPLICATE

Order Date: 04/01/2026
Business Date: 04/01/2026
TIME ORDER
FOR TODAY 05:45 PM

Taken By: Nikkilyn
04/01/2026 05:51:28 PM
Transaction No: 222197026

Item	QTY	Price
Build Your Own Large	4	59.98
DESSERT		1.00
Build Your Own Large Peppermi	4	70.98
DESSERT		1.50
Subtotal		130.92
Discounts		65.46
Order Total		65.46
Total		65.46
Visa 8858		65.46

Approval Code: 01000
 Terminal ID: 12700025
 Card Issued: Visa
 Account ID: 8409
 Acquired: 05/0000
 Transaction ID: 105295447
 Merchant ID: 44970-0701873
 Terminal ID: 001
 Application Label: VISA U.S.A.
 AID: A000000000000000
 Response Code: 0

4/01/2026 05:51:28 PM

Receipt Attached

The Preserve at Wilderness Lake CDD
Credit Card Memo Form

Credit Card Charge

4/1/26
Charge Date

Date of Occurrence	Vendor Name	Amount	General Ledger Code & Purpose
4/1/26	American	\$389.00	1100240

Notes:

Order Summary

Order placed Apr. 1, 2026 Order # 114-4385706-0553048

Ship to

The Preserve at Wilderness Lake COO
21320 WILDERNESS LAKE BLVD
LAND O LAKES, FL 34637-7879
United States

Payment method

Visa ending in 8855

[View related transactions](#)

Order Summary

Item(s) Subtotal:	\$489.00
Shipping & Handling:	\$0.00
Total before tax:	\$489.00
Estimated tax to be collected:	\$0.00
Grand Total:	\$489.00

Delivered April 8



Dominoe Standard Portable Pickleball Net - Indoor/Outdoor Regulation Pickleball Net - USAPA Compliant Pickleball Net on Wheels - System Includes Rolling Storage Bag & Locking Wheels

Sold by: Leap-Products

Supplied by: Other

Returnable items: Eligible through May 5, 2026
\$489.00

[Back to top](#)

Publix

Cullie's Corners
 2121 Cullie Hwy
 Gulf Breeze, FL 34639
 Store Manager: Elliott
 813-948-9819



6877 43R 089 270

UMBRAL MILK CHCCT 5.99 T F
 UMBRAL MILK CHCCT 5.99 T F
 ESTR 2.36" EGGS 2.49 T F
 ESTR 2.36" EGGS 2.49 T F
 TAX EXEMPT

Under Total 16.96
 Grand Total 16.96
 Credit Payment 16.96
 TAX FDRGIVEH 1.19
 Change 0.00

Receipt ID: 0877 43R 089 270

PREPSTG:
 Card #: 080110
 Reference #: 13409516
 Acct #: XXXXXXXXXX28654
 Purchase VISA
 Amount: \$16.95
 Auth #: 713023

DEBIT CARD PURCHASE
 4000000000000000 VISA CREDIT
 Entry Method: Chip Read
 Code: 150001

Our cashier was brilliant.
 4/13/2016 18:57:58 6877 43R 089 270

Join the Publix family!
 Apply today at apply.publix.jobs.
 We're an equal opportunity employer.

Publix Super Markets, Inc.

Receipt Attached

The Preserve at Wilderness Lake CDD
 Credit Card Memo Form

Credit Card Charge

Charge Date

4/3/2016

Date of Occurrence	Vendor Name	Amount	General Ledger Code & Purpose
4/3/2016	Publix	\$16.96	1180200 Eggs Shrimp

Notes:

Receipt Attached

The Preserve at Wilderness Lake CDD
Credit Card Memo Form

Credit Card Charge

Charge Date

4/3/26

Date of Occurrence	Vendor Name	Amount	General Ledger Code & Purpose
4/3/26	Sam's Club	\$64.96	

1180180	3248	
1180210	3248	Egg fruits

Notes:



4852 TAMPA, FL
C 813) 929 - 7010
Visit SamsClub.com

04/03/26 15:22 2376 04852 085 4594

X MEMBER 101-*****3736

THANK YOU,
THE

E 307038 PRETZELS F 64.96 M
SUBTOTAL 64.96

TOTAL 64.96
VISA TEND 64.96

VISA CREDIT **** * 8868 1 2

APPROVAL # 413032
RID 4000000031010
ARC 002024E0EAD06950
TERMINAL # 29816706

*NO SIGNATURE REQUIRED

04/03/26 16:23:38

CHANGE DUE 0.00

You earned \$1.30 Sam's Cash with Plus. Check all services and savings at SamsClub.com/locount

ITEMS SOLD 1

TC# 1230 4572 8494 3317 1009



Save time. Order ahead.
SamsClub.com/clubpickup
04/03/26 16:24:03

MEMBER COPY

Receipt Attached

The Preserve at Wilderness Lake CDD
Credit Card Memo Form

Credit Card Charge

4/3/2021
Charge Date

Date of Occurrence	Vendor Name	Amount	General Ledger Code & Purpose
4/3/21	Purvis Airt	\$259.80	1180200 Site Work

Notes:

Bounce A Lot Inflatables

1106 Sunset Lane

Lutz, FL 33549

813-996-2935 office

www.BounceALotInflatables.com

CustomerService@BounceALotInflatables.com

"We Rent FUN!"



Bounce A Lot Inflatables & Events
1106 Sunset Lane (payments & main
mailing address)
Lutz, FL 33549
813-996-2935
BounceALotInflatables.com

**Important Information - Please
Read Below!**

04/04/2026 12:00pm, 04/04/2026 02:00pm

Preserve at Wilderness Lake

Ellen - (Tish) Dobson

21320 Wilderness Lake Preserve Blvd.



Land O' Lakes, FL 34637

t Dobson@vestapropertyservices.com

813 995-2437 // 813-758-4841 Tish /

Order Created by: Patricia "Chula" Riebenack

Customer Comments: DELIVERY AFTER 7:00am Okay / Power available on site /

		Sat, Apr 4 12:00 → 2:00 pm	
	Tropical Animals Bouncer UNIT #123	\$127.00	x 1 = \$127.00
	^NFW* - Football Quarterback Challenge UNIT #345	\$157.00	x 1 = \$157.00

SubTotal		\$284.00
Park Set Up Yes - Event is at a PUBLIC / PRIVATE PARK / BUSINESS / APARTMENT location	\$20.00	\$304.00
Damage Waiver Yes - I want to include the damage waiver	\$15.20	\$319.20
Fuel Cost - I understand	\$10.00	\$329.20
Travel Fee for 34637	\$9.00	\$338.20

Coupon: Freq Renter (10%)	-	\$309.80
	\$28.40	
Tax Exempt	\$0.00	\$309.80

Total \$309.80

Chula - 03/25/2025 12:37pm Card on File Payment (8858) \$50.00

Customer - 04/03/2026 09:04am Credit Card (Visa, MC, Discover, Amex) Payment (8858) \$259.80

Due \$0.00

Receipt Attached

The Preserve at Wilderness Lake CDD
Credit Card Memo Form

Credit Card Charge

Charge Date 4/16/26

Date of Occurrence	Vendor Name	Amount	General Ledger Code & Purpose
4/16/26	Pet Supplies Plus	\$15.98	1140120

Notes:

PET SUPPLIES PLUS.

23703 417,02e Lakes Shopping Center Dr
Lauder Lakes, FL 34679
USA
973-575-9758

Store: 4011 Date: 4/16/2026
Revised: 401401 Time: 02:35 PM
Account ID: 401101100049535
Operator ID: 401422
Team Member: Ethel
Receipt #: 410009257166
Attendant: Tish Dobson

ITEM NAME	QTY	PRICE	TOTAL
PESTEL BLENDING EASY CLEAN 4	1	\$15.98	\$15.98
062326000405		Unit	
Subtotal			\$15.98
Local tax			\$0.00
Total			\$15.98
Card	Visa	0050	\$15.98

ALL PURCHASES ARE SUBJECT TO A 30-DAY RETURN POLICY WITH
RECEIPT. RETURNS MUST BE RECEIVED AT ORIGINAL
PAYMENT CARD. RETURNS ONLY ALLOWED IF DEFECTIVE
RETURN/EXCHANGE POLICY MAY VARY BY JURISDICTION.
LIMITED AND APPLICABLE FRANCHISE LIMITATIONS

IF YOU DON'T SEE YOUR ITEM PET SUPPLIES PLUS STORE
CONTACT US TO LEARN MORE.
Website: pet-supplies-plus.com
pet-supplies-plus-franchise.com

*** YOUR OPINION MATTERS ***
TELL US ABOUT YOUR EXPERIENCE BY VISITING
WWW.PETSUPPLIES.COM



Receipt Attached

The Preservers at Wilderness Lake CDD
Credit Card Memo Form

Credit Card Charge _____ Charge Date 4/7/26

Date of Occurrence	Vendor Name	Amount	General Ledger Code & Purpose
<u>4/7/26</u>	<u>Amazon</u>	<u>353.82</u>	<u>1284180</u>

Notes: _____

Order Summary

Order placed April 7, 2026 Order # 114-3093768-1641R29

Ship to

The Preserve at Wilderness Lake CDD
21473 WILDERNESS LAKE BLVD
LAND O' LAKES, FL 34637-7879
United States

Payment method

Visa ending in 8858

[View related transactions](#)

Order Summary

Item(s) Subtotal:	\$53.82
Shipping & Handling:	\$2.99
Free Shipping:	-\$7.99
Total before tax:	\$53.82
Estimated tax to be collected:	\$0.00
Grand Total:	\$53.82

Delivered April 7

Your package was left near the front door or porch.



Frito-Lay Ultimate Classic Snacks Package, Variety Assortment of Chips, Cookies, Crackers, & Nuts, 0.56 ounces (Pack of 40) (Packaging May Vary)

Sold by Amazon.com

Supplied by Other

Return items: Eligible through May 7, 2026

\$26.81

Delivered April 7

It was handed directly to a receptionist or someone at a front desk.



Frito-Lay Ultimate Classic Snacks Package, Variety Assortment of Chips, Cookies, Crackers, & Nuts, 0.56 ounces (Pack of 40) (Packaging May Vary)

Sold by Amazon.com

Supplied by Other

Return items: Eligible through May 7, 2026

\$26.91

[Back to top](#)



duke-energy.com
877.372.6477

Your Summary Bill

THE PRESERVE WILDERNESS LAKE

Bill date Apr 19, 2026
For service Mar 4 - Apr 2
30 days

Collective account number: 9300 0001 3787

If you have questions, you can reach us at collectivebillingdef@duke-energy.com.

Billing summary

Previous Amount Due	\$1,338.41
Payment Received Apr 01	-1,338.41
Current Electric Charges	1,387.42
Taxes	36.65
Total Amount Due May 04	\$1,424.27

Billing summary by account

Account Number	Service Address	Totals
910089681175	21533 CORMORANT COVE DR LAND O LAKES FL 34637	33.38
910089628071	0 WILDERNESS LAKES BLVD LAND O LAKES FL 34639	141.57
910089621488	21726 CORMORANT COVE DR LAND O LAKES FL 34637	30.80
910089621115	21320 WILDERNESS LAKE BLVD LAND O LAKES FL 34637	156.12
910089599693	21218 QUIET HAVEN CT LAND O LAKES FL 34637	30.80
910089598189	7809 STONELEIGH DR LAND O LAKES FL 34637	40.38

DUKE ENERGY

Late payments are subject to a 1.0% late charge.

Please return this portion with your payment. Thank you for your business.



Duke Energy Return Mail
PO Box 1094
Charlotte, NC 28201-1094

Collective account number
9300 0001 3787

\$1,424.27
by May 4

After 90 days from bill date, a
late charge will apply.

000006 000600013



THE PRESERVE WILDERNESS LAKE
250 INTERNATIONAL PKWY STE 208
LAKE MARY FL 32746-5062

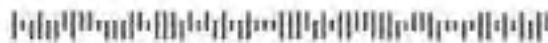

Duke Energy Payment Processing
PO Box 1094
Charlotte, NC 28201-1094

889300000137870006600000000000000000014242700001424278

DUKE ENERGY 20260419 022 02 57 47 11 00000013



Account Number	Service Address	Totals
910089583588	20750 WILDERNESS LAKES BLVD LAND O LAKES FL 34639	54.23
910089576696	21320 WILDERNESS LAKE BLVD LAND O LAKES FL 34637	55.72
910089568373	21320 WILDERNESS LAKE BLVD LAND O LAKES FL 34637	136.47
910089552549	21320 WILDERNESS LAKE BLVD LAND O LAKES FL 34637	30.80
910089540917	7532 GRASMERE DR LAND O LAKES FL 34637	30.80
910089532399	7250 AMBLESIDE DR LITE LAND O LAKES FL 34637	106.04
910089520343	21547 WILDERNESS LAKE BLVD LAND O LAKES FL 34637	115.50
910089498590	21320 WILDERNESS LAKE BLVD LAND O LAKES FL 34637	30.80
910089497028	21320 WILDERNESS LAKE BLVD LAND O LAKES FL 34637	30.80
910089492247	21320 WILDERNESS LAKE BLVD LAND O LAKES FL 34637	30.80
910089467486	21433 WILDERNESS LAKE BLVD LAND O LAKES FL 34637	30.80
910089447664	7154 MOSS LEDGE RUN LAND O LAKES FL 34637	30.80
910089443412	21320 WILDERNESS LAKE BLVD LAND O LAKES FL 34637	38.03
910089431616	21320 WILDERNESS LAKE BLVD LAND O LAKES FL 34637	704.91
910089423195	21320 WILDERNESS LAKE BLVD LAND O LAKES FL 34637	30.80
910089383730	7452 NIGHT HERON DR LAND O LAKES FL 34637	53.92
	Total Charges	51,424.27

FL00000001 5/1/17 10:02:00 AM 17/05/17 10:02:00 AM





Energy Matters

Account Information	Billing Details		Amounts
910089681175 THE PRESERVE WILDERNESS LAKE 21533 CORMORANT COVE DR LAND O LAKES FL 34637	General Service Non-Demand Sec (GS-1)	Customer Charge	17.92
	Meter Number: 4429770	Energy Charge	9.85
	Bill Period: Mar 04 - Apr 02	Fuel Charge	4.53
	Present Read: 5556	Asset Securitization Charge	0.20
	Previous Read: 5453		
	Billed Usage: 103		
	Billed kWh: 103.000		
		Regulatory Assessment Fee	0.03
		Gross Receipts Tax	0.83
		Total	\$33.38
910089628071 THE PRESERVE WILDERNESS LAKE O WILDERNESS LAKES BLVD LAND O LAKES FL 34639	General Service Non-Demand Sec (GS-1)	Customer Charge	17.92
	Meter Number: 4486990	Energy Charge	80.93
	Bill Period: Mar 04 - Apr 02	Fuel Charge	37.81
	Present Read: 68754	Asset Securitization Charge	1.65
	Previous Read: 67908		
	Billed Usage: 846		
	Billed kWh: 846.000		
		Regulatory Assessment Fee	0.12
		Gross Receipts Tax	8.54
		Total	\$141.57
910089621488 THE PRESERVE WILDERNESS LAKE 21726 CORMORANT COVE DR LAND O LAKES FL 34637	General Service Non-Demand Sec (GS-1)	Customer Charge	17.92
	Meter Number: 4427515	Energy Charge	0.76
	Bill Period: Mar 04 - Apr 02	Fuel Charge	0.35
	Present Read: 506	Asset Securitization Charge	0.02
	Previous Read: 498	Minimum Bill Adjustment	10.95
	Billed Usage: 8		
	Billed kWh: 8.000		
		Regulatory Assessment Fee	0.03
		Gross Receipts Tax	0.77
		Total	\$30.80
910089621115 THE PRESERVE WILDERNESS LAKE 21320 WILDERNESS LAKE BLVD LAND O LAKES FL 34637	General Service Non-Demand Sec (GS-1)	Customer Charge	17.92
	Meter Number: 4412767	Energy Charge	90.50
	Bill Period: Mar 04 - Apr 02	Fuel Charge	41.83
	Present Read: 58257	Asset Securitization Charge	1.84
	Previous Read: 57311		
	Billed Usage: 946		
	Billed kWh: 946.000		
		Regulatory Assessment Fee	0.13
		Gross Receipts Tax	3.90
		Total	\$156.12
810089599693 THE PRESERVE WILDERNESS LAKE 21218 QUIET HAVEN CT LAND O LAKES FL 34637	General Service Non-Demand Sec (GS-1)	Customer Charge	17.92
	Meter Number: 4426437	Energy Charge	6.89
	Bill Period: Mar 04 - Apr 02	Fuel Charge	3.18



Account Information	Billing Details		Amounts
	Present Read: 4869	Asset Securitization Charge: 0.14	
	Previous Read: 4797	Minimum Bill Adjustment: 1.67	
	Billed Usage: 72		
	Billed kWh: 72.000		
		Regulatory Assessment Fee: 0.03	\$0.80
		Gross Receipts Tax: 0.77	
		Total	\$30.80
910089598189 THE PRESERVE WILDERNESS LAKE 7809 STONELEIGH DR LAND O LAKES FL 34637	General Service Non-Demand Sec (GS-1)	Customer Charge: 17.92	
	Meter Number: 4426432	Energy Charge: 14.45	
	Bill Period: Mar 04 - Apr 02	Fuel Charge: 6.68	\$39.34
	Present Read: 14048	Asset Securitization Charge: 0.29	
	Previous Read: 13897		
	Billed Usage: 151		
	Billed kWh: 151.000		
		Regulatory Assessment Fee: 0.03	\$1.04
		Gross Receipts Tax: 1.01	
		Total	\$40.38
910089583588 THE PRESERVE WILDERNESS LAKE 20750 WILDERNESS LAKES BLVD LAND O LAKES FL 34639	General Service Non-Demand Sec (GS-1)	Customer Charge: 17.92	
	Meter Number: 4418605	Energy Charge: 23.54	
	Bill Period: Mar 04 - Apr 02	Fuel Charge: 10.88	\$52.82
	Present Read: 16927	Asset Securitization Charge: 0.48	
	Previous Read: 16681		
	Billed Usage: 246		
	Billed kWh: 246.000		
		Regulatory Assessment Fee: 0.05	\$1.41
		Gross Receipts Tax: 1.36	
		Total	\$54.23
910089576696 THE PRESERVE WILDERNESS LAKE 21320 WILDERNESS LAKE BLVD LAND O LAKES FL 34637	General Service Non-Demand Sec (GS-1)	Customer Charge: 17.92	
	Meter Number: 4407268	Energy Charge: 11.39	
	Bill Period: Mar 04 - Apr 02	Fuel Charge: 5.26	\$34.80
	Present Read: 4231	Asset Securitization Charge: 0.23	
	Previous Read: 4112		
	Billed Usage: 119		
	Billed kWh: 119.000		
		Regulatory Assessment Fee: 0.03	\$0.92
		Gross Receipts Tax: 0.89	
		Total	\$35.72
910089568373 THE PRESERVE WILDERNESS LAKE 21320 WILDERNESS LAKE BLVD LAND O LAKES FL 34637	General Service Non-Demand Sec (GS-1)	Customer Charge: 17.92	
	Meter Number: 4422414	Energy Charge: 77.58	
	Bill Period: Mar 04 - Apr 02	Fuel Charge: 35.86	\$132.94
	Present Read: 62276	Asset Securitization Charge: 1.58	
	Previous Read: 61465		
	Billed Usage: 811		
	Billed kWh: 811.000		

duke-energy.com (202004172202050) / meter (15-000000014)





Account Information	Billing Details		Amounts
		Regulatory Assessment Fee	0.12
		Gross Receipts Tax	3.41
		Total	\$136.47
91008952549 THE PRESERVE WILDERNESS LAKE 21320 WILDERNESS LAKE BLVD LAND O LAKES FL 34637	General Service Non-Demand Sec (GS-1) Meter Number: 4420314 Bill Period: Mar 04 - Apr 02 Present Read: 4763 Previous Read: 4708 Billed Usage: 55 Billed kWh: 55.000	Customer Charge Energy Charge Fuel Charge Asset Securitization Charge Minimum Bill Adjustment	17.92 5.27 2.43 0.11 4.27
		Regulatory Assessment Fee	0.03
		Gross Receipts Tax	0.77
		Total	\$30.80
910089540917 THE PRESERVE WILDERNESS LAKE 7532 GRASMERE DR LAND O LAKES FL 34637	General Service Non-Demand Sec (GS-1) Meter Number: 4414861 Bill Period: Mar 04 - Apr 02 Present Read: 388 Previous Read: 382 Billed Usage: 6 Billed kWh: 6.000	Customer Charge Energy Charge Fuel Charge Asset Securitization Charge Minimum Bill Adjustment	17.92 0.58 0.27 0.01 11.23
		Regulatory Assessment Fee	0.03
		Gross Receipts Tax	0.77
		Total	\$30.80
910089532339 THE PRESERVE WILDERNESS LAKE 7250 AMBLESIDE DR LITE LAND O LAKES FL 34637	General Service Non-Demand Sec (GS-1) Meter Number: 3523173 Bill Period: Mar 04 - Apr 02 Present Read: 17951 Previous Read: 17349 Billed Usage: 602 Billed kWh: 602.000	Customer Charge Energy Charge Fuel Charge Asset Securitization Charge	17.92 57.59 26.62 1.17
		Regulatory Assessment Fee	0.09
		Gross Receipts Tax	2.55
		Total	\$106.04
910089520343 THE PRESERVE WILDERNESS LAKE 21547 WILDERNESS LAKE BLVD LAND O LAKES FL 34637	General Service Non-Demand Sec (GS-1) Meter Number: 4431126 Bill Period: Mar 04 - Apr 02 Present Read: 28829 Previous Read: 28162 Billed Usage: 667 Billed kWh: 667.000	Customer Charge Energy Charge Fuel Charge Asset Securitization Charge	17.92 63.80 29.49 1.30
		Regulatory Assessment Fee	0.10
		Gross Receipts Tax	2.85
		Total	\$115.50

B:\HR\mawcove\020001\02000137\46-15-02000013



Account information	Billing Details		Amounts
910089498590 THE PRESERVE WILDERNESS LAKE 21320 WILDERNESS LAKE BLVD LAND O LAKES FL 34637	General Service Non-Demand Sec (GS-1)	Customer Charge	17.92
	Meter Number: 4417789	Energy Charge	7.76
	Bill Period: Mar 04 - Apr 02	Fuel Charge	3.58
	Present Read: 5642	Asset Securitization Charge	0.16
	Previous Read: 5561	Minimum Bill Adjustment	0.58
Billed Usage: 81			
Billed kWh: 81.000			
	Regulatory Assessment Fee	0.03	
	Gross Receipts Tax	0.77	\$0.80
	Total		\$30.80
910089497028 THE PRESERVE WILDERNESS LAKE 21320 WILDERNESS LAKE BLVD LAND O LAKES FL 34637	General Service Non-Demand Sec (GS-1)	Customer Charge	17.92
	Meter Number: 3603226	Energy Charge	7.08
	Bill Period: Mar 04 - Apr 02	Fuel Charge	3.27
	Present Read: 5256	Asset Securitization Charge	0.14
	Previous Read: 5182	Minimum Bill Adjustment	1.59
Billed Usage: 74			
Billed kWh: 74.000			
	Regulatory Assessment Fee	0.03	
	Gross Receipts Tax	0.77	\$0.80
	Total		\$30.80
910089492247 THE PRESERVE WILDERNESS LAKE 21320 WILDERNESS LAKE BLVD LAND O LAKES FL 34637	Residential Service (RS-1)	Customer Charge	14.27
	Meter Number: 4421286	Energy Charge	0.55
	Bill Period: Mar 04 - Apr 02	Fuel Charge	0.25
	Present Read: 2220	Asset Securitization Charge	0.01
	Previous Read: 2214	Minimum Bill Adjustment	14.92
Billed Usage: 6			
Billed kWh: 6.000			
	Regulatory Assessment Fee	0.03	
	Gross Receipts Tax	0.77	\$0.80
	Total		\$30.80
910089467486 THE PRESERVE WILDERNESS LAKE 21433 WILDERNESS LAKE BLVD LAND O LAKES FL 34637	General Service Non-Demand Sec (GS-1)	Customer Charge	17.92
	Meter Number: 4429848	Energy Charge	0.95
	Bill Period: Mar 04 - Apr 02	Fuel Charge	0.44
	Present Read: 345	Asset Securitization Charge	0.02
	Previous Read: 335	Minimum Bill Adjustment	10.67
Billed Usage: 10			
Billed kWh: 10.000			
	Regulatory Assessment Fee	0.03	
	Gross Receipts Tax	0.77	\$0.80
	Total		\$30.80
910089447664 THE PRESERVE WILDERNESS LAKE 7154 MOSS LEDGE RUN LAND O LAKES FL 34637	General Service Non-Demand Sec (GS-1)	Customer Charge	17.92
	Meter Number: 4444513	Energy Charge	1.14
	Bill Period: Mar 04 - Apr 02	Fuel Charge	0.53
	Present Read: 650	Asset Securitization Charge	0.02

DUKE ENERGY FLORIDA 202504102020567.xls 17-000000013





Account Information	Billing Details		Amounts
	Previous Read: 638	Minimum Bill Adjustment	10.39
	Billed Usage: 12		
	Billed kWh: 12.000		
		Regulatory Assessment Fee	0.03
		Gross Receipts Tax	0.77
		Total	\$0.80
910089443412 THE PRESERVE WILDERNESS LAKE 21320 WILDERNESS LAKE BLVD LAND O LAKES FL 34637	General Service Non-Demand Sec (GS-1)	Customer Charge	17.97
	Meter Number: 4417902	Energy Charge	12.90
	Bill Period: Mar 04 - Apr 02	Fuel Charge	5.97
	Present Read: 7942	Asset Securitization Charge	0.26
	Previous Read: 7807		
	Billed Usage: 135		
	Billed kWh: 135.000		
		Regulatory Assessment Fee	0.03
		Gross Receipts Tax	0.95
		Total	\$37.05
			\$0.98
		Total	\$38.03
910089431616 THE PRESERVE WILDERNESS LAKE 21320 WILDERNESS LAKE BLVD LAND O LAKES FL 34637	General Service Non-Demand Sec (GS-1)	Customer Charge	17.92
	Meter Number: 4426401	Energy Charge	122.55
	Bill Period: Mar 04 - Apr 02	Fuel Charge	56.65
	Present Read: 54351	Asset Securitization Charge	8.50
	Previous Read: 53070		
	Billed Usage: 1281		
	Billed kWh: 1281.000		
		Regulatory Assessment Fee	0.17
		Gross Receipts Tax	5.12
		Total	\$199.62
			\$5.29
		Total	\$204.91
910089423195 THE PRESERVE WILDERNESS LAKE 21320 WILDERNESS LAKE BLVD LAND O LAKES FL 34637	General Service Non-Demand Sec (GS-1)	Customer Charge	17.92
	Meter Number: 4426400	Energy Charge	3.15
	Bill Period: Mar 04 - Apr 02	Fuel Charge	1.46
	Present Read: 2245	Asset Securitization Charge	0.06
	Previous Read: 2212	Minimum Bill Adjustment	7.41
	Billed Usage: 33		
	Billed kWh: 33.000		
		Regulatory Assessment Fee	0.03
		Gross Receipts Tax	0.77
		Total	\$30.80
			\$0.80
		Total	\$30.80
910089383730 THE PRESERVE WILDERNESS LAKE 7452 NIGHT HERON DR LAND O LAKES FL 34637	General Service Non-Demand Sec (GS-1)	Customer Charge	17.92
	Meter Number: 4415554	Energy Charge	23.33
	Bill Period: Mar 04 - Apr 02	Fuel Charge	10.79
	Present Read: 39945	Asset Securitization Charge	0.48
	Previous Read: 39701		
	Billed Usage: 244		
	Billed kWh: 244.000		
		Regulatory Assessment Fee	0.05
		Total	\$52.52
			\$1.40
		Total	\$51.40



duke-energy.com
877.372.8477

Account number 9300 0001 3787

Billing Details - continued

Account Information	Billing Details	Amounts
	Gross Receipts Tax	1.35
	Total	\$53.92
	Total Amount Due	\$1,424.27





WILDERNESS LAKES PRESERVE Account Number: **813-929-9402-041519-5**
PIN: **4128**

Billing Date: **Apr 15, 2026**
Billing Period: **Apr 15 - May 14, 2026**

HI WILDERNESS LAKES PRESERVE.

Thank-you for choosing Frontier, a Verizon Company. Have questions about your bill? Visit us at frontier.com/billing to learn more.



Total balance
\$125.98
Auto Pay is scheduled
May 11

Bill history

Previous balance	\$125.98
Payment received by Apr 15, thank you	-\$125.98

Service summary

	Previous month	Current month
Bundle	\$125.98	\$125.98
Total services	\$125.98	\$125.98

Total balance \$125.98

Manage your account, payments, and services anytime, anywhere with the MyFrontier app. Download your free app today. To learn more visit frontier.com/myfrontierapp

RECEIVED APR 9 4 1126

Earn more. Get started with a business referral and earn up to \$325 per referral. Learn more: <https://www.businessreferralrewards.com>



P.O. Box 211579
Eagan, MN 55121-2879

6780 0107 DY RP 15 04152026 NNNNN 01 001821 0007

WILDERNESS LAKES PRESERVE
250 INTERNATIONAL PKWY STE 208
LAKE MARY FL 32746-5062

You are all set with Auto Pay! To review your account, go to frontier.com or the MyFrontier app.



19800981392994020415190000000000000000125985



WILDERNESS LAKES PRESERVE

Account Number:
813-929-9402-041519-5

PIN:
4128

Billing Date:
Apr 15, 2026

Billing Period:
Apr 15 - May 14, 2026

Don't let an unexpected outage stop your business. Get Frontier Internet Backup to keep your critical systems running. Visit: business.frontier.com/internet-backup

Bundle

Monthly Charges

04.15-05.14	FiberOptic Internet 200 Static IP	\$125.98
	Valued Customer Fiber 500 Upgrade	\$0.00

Bundle Total **\$125.98**

Total current month charges **\$125.98**

BUSINESS
FIBER 5 GIG
INTERNET

Fast just got faster. Get ultrafast internet to handle your most critical business applications today, tomorrow and the future.

855-518-1197
business.frontier.com/fiber-internet



THE PRESERVE AT WILDERNESS L

Account Number:
239-159-2085-030513-5

Billing Date:
Apr 22, 2026

PIN:
2561

Billing Period:
Apr 22 - May 21, 2026

Hi THE PRESERVE AT WILDERNESS L,

Thank-you for choosing Frontier, a Verizon Company. Have questions about your bill? Visit us at frontier.com/billing to learn more.

Bill history

Previous balance	\$145.49
Payment received by Apr 22, thank you	-\$145.49

Service summary

	Previous month	Current month
Internet	\$140.99	\$140.99
Other	\$4.50	\$4.50
Total services	\$145.49	\$145.49

Total balance **\$145.49**

Total balance

\$145.49

Auto Pay is scheduled

May 18



Manage your account, payments, and services anytime, anywhere with the MyFrontier app. Download your free app today. To learn more visit frontier.com/myfrontierapp

Earn more. Get started with a business referral and earn up to \$325 per referral. Learn more: <https://www.businessreferralrewards.com>



P.O. Box 211579
Eagan, MN 55121-2879

6790 0107 DY RP 22 04232026 NNNNNN 01 007721 0023

THE PRESERVE AT WILDERNESS L
250 INTERNATIONAL PKWY STE 208
LAKE MARY FL 32746-5062

You are all set with Auto Pay! To review your account, go to frontier.com or the MyFrontier app.



77700023915920850305130000000000000000145495



Don't let an unexpected outage stop your business. Get Frontier Internet Backup to keep your critical systems running. Visit: business.frontier.com/internet-backup



Internet

Monthly Charges

04.22-05.21	Business Fiber Internet 700/700M	\$115.99
	1 Usable Static IP Address	\$25.00

Internet Total **\$140.99**

If your bill reflects that you owe a Balance Forward, you must make a payment immediately in order to avoid collection activities. You must pay a minimum of \$145.49 by your due date to avoid disconnection of your local service. All other charges should be paid by your due date to keep your account current.



Other Charges

Monthly Charges

04.22-05.21	Printed Bill Fee	\$4.50
-------------	------------------	--------

Other Charges Total **\$4.50**

Total current month charges **\$145.49**

**BUSINESS
FIBER 5 GIG
INTERNET**

Fast just got faster. Get ultrafast internet to handle your most critical business applications today, tomorrow and the future.

855-518-1197
business.frontier.com/fiber-internet





PASCO COUNTY UTILITIES
 CUSTOMER INFORMATION & SERVICES
 P.O. BOX 2139
 NEW PORT RICHEY, FL 34656-2139

LAND O' LAKES (813) 235-6012
 NEW PORT RICHEY (727) 847-8131
 DADE CITY (352) 521-4285

UtilCustServ@MyPasco.net
 Pay By Phone: 1-855-786-5344

1 0 1
 22-70147

WILDERNESS LK PRESEV

Service Address: **0 WHISPERING WIND DR**
 Bill Number: 24410519
 Billing Date: 5/5/2026
 Billing Period: 3/13/2026 to 4/14/2026

Account #	Customer #
0350530	01289194
Please use the 15-digit number below when making a payment through your bank	
035053001289194	

New Water, Sewer, Reclaim rates, fees, and charges took effect Oct. 1, 2025.
 Please visit bit.ly/pcurates for details.

Service	Meter #	Previous		Current		# of Days	Consumption in thousands
		Date	Read	Date	Read		
Irrig Potable	13402056	3/13/2026	1754	4/14/2026	1796	32	42

Usage History		Irrigation
Water		
April 2026		42
March 2026		61
February 2026		54
January 2026		8
December 2025		0
November 2025		0
October 2025		0
September 2025		28
August 2025		26
July 2025		43
June 2025		71
May 2025		43

Transactions		
Previous Bill		510.96
Payment 04/20/26		-510.96 CR
Balance Forward		0.00
Current Transactions		
Irrigation		
Water Base Charge		11.00
Water Tier 1	10.0 Thousand Gals X \$3.47	34.70
Water Tier 2	5.0 Thousand Gals X \$6.94	34.70
Water Tier 3	27.0 Thousand Gals X \$9.36	252.72
Total Current Transactions		333.12
TOTAL BALANCE DUE		\$333.12

Annual Water Quality Report: The 2025 Consumer Confidence Report is available online at bit.ly/PascoRegional2025. To request a paper copy, please call (813) 929-2733.

Please return this portion with payment



TO PAY ONLINE, VISIT pascoeasypay.pascocountyfl.net

Check this box if entering change of mailing address on back.

Account # 0350530
 Customer # 01289194
 Balance Forward 0.00
 Current Transactions 333.12

Total Balance Due	\$333.12
Due Date	5/22/2026

10% late fee will be applied if paid after due date

The Total Due will be electronically transferred on 05/22/2026.

WILDERNESS LK PRESEV
 250 INTERNATIONAL PARKWAY 208
 LAKE MARY FL 32746

PASCO COUNTY UTILITIES
 CUSTOMER INFORMATION & SERVICES
 P.O. BOX 2139
 NEW PORT RICHEY, FL 34656-2139



PASCO COUNTY UTILITIES
 CUSTOMER INFORMATION & SERVICES
 P.O. BOX 2139
 NEW PORT RICHEY, FL 34656-2139

LAND O' LAKES (813) 235-6012
 NEW PORT RICHEY (727) 847-8131
 DADE CITY (352) 521-4285

UtilCustServ@MyPasco.net
 Pay By Phone: 1-855-786-5344

1 0 1
 22-70147

WILDERNESS LK PRESER

Service Address: **21922 WAVERLY SHORES LANE**
 Bill Number: 24410524
 Billing Date: 5/5/2026
 Billing Period: 3/13/2026 to 4/14/2026

Account #	Customer #
0350555	01289193
Please use the 15-digit number below when making a payment through your bank	
035055501289193	

New Water, Sewer, Reclaim rates, fees, and charges took effect Oct. 1, 2025.
 Please visit bit.ly/pcurates for details.

Service	Meter #	Previous		Current		# of Days	Consumption in thousands
		Date	Read	Date	Read		
Irrig Potable	13410468	3/13/2026	3140	4/14/2026	3156	32	16

Usage History

Month	Water	Irrigation
April 2026		16
March 2026		15
February 2026		7
January 2026		6
December 2025		6
November 2025		21
October 2025		20
September 2025		0
August 2025		9
July 2025		9
June 2025		9
May 2025		8

Transactions

Previous Bill	80.40
Payment 04/20/26	-80.40 CR
Balance Forward	0.00
Current Transactions	
Irrigation	
Water Base Charge	11.00
Water Tier 1	10.0 Thousand Gals X \$3.47 = 34.70
Water Tier 2	5.0 Thousand Gals X \$6.94 = 34.70
Water Tier 3	1.0 Thousand Gals X \$9.36 = 9.36
Total Current Transactions	89.76
TOTAL BALANCE DUE	\$89.76

Annual Water Quality Report: The 2025 Consumer Confidence Report is available online at bit.ly/PascoRegional2025. To request a paper copy, please call (813) 929-2733.

Please return this portion with payment



TO PAY ONLINE, VISIT pascoeasypay.pascocountyfl.net

Check this box if entering change of mailing address on back.

Account # 0350555
 Customer # 01289193
 Balance Forward 0.00
 Current Transactions 89.76

Total Balance Due	\$89.76
Due Date	5/22/2026

10% late fee will be applied if paid after due date

The Total Due will be electronically transferred on 05/22/2026.

WILDERNESS LK PRESER
 250 INTERNATIONAL PARKWAY STE 208
 LAKE MARY FL 32746-5062

PASCO COUNTY UTILITIES
 CUSTOMER INFORMATION & SERVICES
 P.O. BOX 2139
 NEW PORT RICHEY, FL 34656-2139



PASCO COUNTY UTILITIES
 CUSTOMER INFORMATION & SERVICES
 P.O. BOX 2139
 NEW PORT RICHEY, FL 34656-2139

LAND O' LAKES (813) 235-6012
 NEW PORT RICHEY (727) 847-8131
 DADE CITY (352) 521-4285

UtilCustServ@MyPasco.net
 Pay By Phone: 1-855-786-5344

1 0 1
 22-70147

WILDERNESS LK PRESER

Service Address: **7639 GRASMERE DR**
 Bill Number: 24410525
 Billing Date: 5/5/2026
 Billing Period: 3/13/2026 to 4/14/2026

Account #	Customer #
0350560	01289193
Please use the 15-digit number below when making a payment through your bank	
035056001289193	

New Water, Sewer, Reclaim rates, fees, and charges took effect Oct. 1, 2025.
 Please visit bit.ly/pcurates for details.

Service	Meter #	Previous		Current		# of Days	Consumption in thousands
		Date	Read	Date	Read		
Irrig Potable	13401909	3/13/2026	1	4/14/2026	1	32	0

Usage History

	Water	Irrigation
April 2026		0
March 2026		0
February 2026		0
January 2026		0
December 2025		0
November 2025		0
October 2025		0
September 2025		0
August 2025		0
July 2025		0
June 2025		0
May 2025		0

Transactions

Previous Bill	11.00
Payment 04/20/26	-11.00 CR
Balance Forward	0.00
Current Transactions	
Irrigation	
Water Base Charge	11.00
Total Current Transactions	11.00
TOTAL BALANCE DUE	\$11.00

Annual Water Quality Report: The 2025 Consumer Confidence Report is available online at bit.ly/PascoRegional2025. To request a paper copy, please call (813) 929-2733.

Please return this portion with payment



TO PAY ONLINE, VISIT pascoeasypay.pascocountyfl.net

Check this box if entering change of mailing address on back.

Account # 0350560
 Customer # 01289193
 Balance Forward 0.00
 Current Transactions 11.00

Total Balance Due	\$11.00
Due Date	5/22/2026

10% late fee will be applied if paid after due date

The Total Due will be electronically transferred on 05/22/2026.

WILDERNESS LK PRESER
 250 INTERNATIONAL PARKWAY STE 208
 LAKE MARY FL 32746-5062

PASCO COUNTY UTILITIES
 CUSTOMER INFORMATION & SERVICES
 P.O. BOX 2139
 NEW PORT RICHEY, FL 34656-2139



PASCO COUNTY UTILITIES
 CUSTOMER INFORMATION & SERVICES
 P.O. BOX 2139
 NEW PORT RICHEY, FL 34656-2139

LAND O' LAKES (813) 235-6012
 NEW PORT RICHEY (727) 847-8131
 DADE CITY (352) 521-4285

UtilCustServ@MyPasco.net
 Pay By Phone: 1-855-786-5344

1 0 1
 22-70147

WILDERNESS LK PRESER

Service Address: **21539 CORMORANT COVE DR**
 Bill Number: 24410523
 Billing Date: 5/5/2026
 Billing Period: 3/13/2026 to 4/14/2026

Account #	Customer #
0350550	01289193
Please use the 15-digit number below when making a payment through your bank	
035055001289193	

New Water, Sewer, Reclaim rates, fees, and charges took effect Oct. 1, 2025.
 Please visit bit.ly/pcurates for details.

Service	Meter #	Previous		Current		# of Days	Consumption in thousands
		Date	Read	Date	Read		
Irrig Potable	13410473	3/13/2026	3	4/14/2026	3	32	0

Usage History

	Water	Irrigation
April 2026		0
March 2026		0
February 2026		0
January 2026		0
December 2025		0
November 2025		0
October 2025		0
September 2025		0
August 2025		0
July 2025		0
June 2025		0
May 2025		0

Transactions

Previous Bill	11.00
Payment 04/20/26	-11.00 CR
Balance Forward	0.00
Current Transactions	
Irrigation	
Water Base Charge	11.00
Total Current Transactions	11.00
TOTAL BALANCE DUE	\$11.00

Annual Water Quality Report: The 2025 Consumer Confidence Report is available online at bit.ly/PascoRegional2025. To request a paper copy, please call (813) 929-2733.

Please return this portion with payment



TO PAY ONLINE, VISIT pascoeasypay.pascocountyfl.net

Check this box if entering change of mailing address on back.

Account # 0350550
 Customer # 01289193
 Balance Forward 0.00
 Current Transactions 11.00

Total Balance Due	\$11.00
Due Date	5/22/2026

10% late fee will be applied if paid after due date

The Total Due will be electronically transferred on 05/22/2026.

WILDERNESS LK PRESER
 250 INTERNATIONAL PARKWAY STE 208
 LAKE MARY FL 32746-5062

PASCO COUNTY UTILITIES
 CUSTOMER INFORMATION & SERVICES
 P.O. BOX 2139
 NEW PORT RICHEY, FL 34656-2139



PASCO COUNTY UTILITIES
 CUSTOMER INFORMATION & SERVICES
 P.O. BOX 2139
 NEW PORT RICHEY, FL 34656-2139

LAND O' LAKES (813) 235-6012
 NEW PORT RICHEY (727) 847-8131
 DADE CITY (352) 521-4285

UtilCustServ@MyPasco.net
 Pay By Phone: 1-855-786-5344

1 0 1
 22-70147

WILDERNESS LK PRESER

Service Address: **20750 WILDERNESS LAKE BOULEVARD**
 Bill Number: 24410521
 Billing Date: 5/5/2026
 Billing Period: 3/13/2026 to 4/14/2026

Account #	Customer #
0350540	01289193
Please use the 15-digit number below when making a payment through your bank	
035054001289193	

New Water, Sewer, Reclaim rates, fees, and charges took effect Oct. 1, 2025.
 Please visit bit.ly/pcurates for details.

Service	Meter #	Previous		Current		# of Days	Consumption in thousands
		Date	Read	Date	Read		
Water	13401489	3/13/2026	23	4/14/2026	23	32	0

Usage History

Month	Usage
April 2026	0
March 2026	0
February 2026	0
January 2026	0
December 2025	0
November 2025	0
October 2025	0
September 2025	0
August 2025	0
July 2025	0
June 2025	0
May 2025	1

Transactions

Previous Bill	34.42
Payment 04/20/26	-34.42 CR
Balance Forward	0.00
Current Transactions	
Water	
Water Base Charge	11.00
Sewer	
Sewer Base Charge	23.42
Total Current Transactions	34.42
TOTAL BALANCE DUE	\$34.42

Annual Water Quality Report: The 2025 Consumer Confidence Report is available online at bit.ly/PascoRegional2025. To request a paper copy, please call (813) 929-2733.

Please return this portion with payment



TO PAY ONLINE, VISIT pascoeasypay.pascocountyfl.net

Check this box if entering change of mailing address on back.

Account # 0350540
 Customer # 01289193
 Balance Forward 0.00
 Current Transactions 34.42

Total Balance Due	\$34.42
Due Date	5/22/2026

10% late fee will be applied if paid after due date

The Total Due will be electronically transferred on 05/22/2026.

WILDERNESS LK PRESER
 250 INTERNATIONAL PARKWAY STE 208
 LAKE MARY FL 32746-5062

PASCO COUNTY UTILITIES
 CUSTOMER INFORMATION & SERVICES
 P.O. BOX 2139
 NEW PORT RICHEY, FL 34656-2139



PASCO COUNTY UTILITIES
 CUSTOMER INFORMATION & SERVICES
 P.O. BOX 2139
 NEW PORT RICHEY, FL 34656-2139

LAND O' LAKES (813) 235-6012
 NEW PORT RICHEY (727) 847-8131
 DADE CITY (352) 521-4285

UtilCustServ@MyPasco.net
 Pay By Phone: 1-855-786-5344

1 0 1
 22-70147

WILDERNESS LK PRESER

Service Address: **0 WAVERLY SHORES LANE**

Bill Number: 24410526

Billing Date: 5/5/2026

Billing Period: 3/13/2026 to 4/14/2026

Account #	Customer #
0350565	01289193
Please use the 15-digit number below when making a payment through your bank	
035056501289193	

New Water, Sewer, Reclaim rates, fees, and charges took effect Oct. 1, 2025.
 Please visit bit.ly/pcurates for details.

Service	Meter #	Previous		Current		# of Days	Consumption in thousands
		Date	Read	Date	Read		
Irrig Potable	13409971	3/13/2026	0	4/14/2026	0	32	0

Usage History

	Water	Irrigation
April 2026		0
March 2026		0
February 2026		0
January 2026		0
December 2025		0
November 2025		0
October 2025		0
September 2025		0
September 2025		0
August 2025		0
July 2025		0
June 2025		0

Transactions

Previous Bill	11.00
Payment 04/20/26	-11.00 CR
Balance Forward	0.00
Current Transactions	
Irrigation	
Water Base Charge	11.00
Total Current Transactions	11.00
TOTAL BALANCE DUE	\$11.00

Annual Water Quality Report: The 2025 Consumer Confidence Report is available online at bit.ly/PascoRegional2025. To request a paper copy, please call (813) 929-2733.

Please return this portion with payment



TO PAY ONLINE, VISIT pascoeasypay.pascocountyfl.net

Check this box if entering change of mailing address on back.

Account # 0350565
 Customer # 01289193
 Balance Forward 0.00
 Current Transactions 11.00

Total Balance Due	\$11.00
Due Date	5/22/2026

10% late fee will be applied if paid after due date

The Total Due will be electronically transferred on 05/22/2026.

WILDERNESS LK PRESER
 250 INTERNATIONAL PARKWAY STE 208
 LAKE MARY FL 32746-5062

PASCO COUNTY UTILITIES
 CUSTOMER INFORMATION & SERVICES
 P.O. BOX 2139
 NEW PORT RICHEY, FL 34656-2139



PASCO COUNTY UTILITIES
 CUSTOMER INFORMATION & SERVICES
 P.O. BOX 2139
 NEW PORT RICHEY, FL 34656-2139

LAND O' LAKES (813) 235-6012
 NEW PORT RICHEY (727) 847-8131
 DADE CITY (352) 521-4285

UtilCustServ@MyPasco.net
 Pay By Phone: 1-855-786-5344

1 0 1
 22-70147

WILDERNESS LK PRESER

Service Address: **21320 WILDERNESS LAKE BOULEVARD**
 Bill Number: 24410522
 Billing Date: 5/5/2026
 Billing Period: 3/13/2026 to 4/14/2026

Account #	Customer #
0350545	01289193
Please use the 15-digit number below when making a payment through your bank	
035054501289193	

New Water, Sewer, Reclaim rates, fees, and charges took effect Oct. 1, 2025.
 Please visit bit.ly/pcurates for details.

Service	Meter #	Previous		Current		# of Days	Consumption in thousands
		Date	Read	Date	Read		
Water	13324742	3/13/2026	5836	4/14/2026	5968	32	132

Usage History

Month	Usage
April 2026	132
March 2026	130
February 2026	74
January 2026	65
December 2025	69
November 2025	57
October 2025	49
September 2025	95
August 2025	51
July 2025	122
June 2025	256
May 2025	131

Transactions

Previous Bill	2,033.12
Payment 04/20/26	-2,033.12 CR
Balance Forward	0.00
Current Transactions	
Water	
Water Base Charge	22.37
Water Tier 1	13.0 Thousand Gals X \$2.18 = 28.34
Water Tier 2	12.0 Thousand Gals X \$3.47 = 41.64
Water Tier 3	13.0 Thousand Gals X \$6.94 = 90.22
Water Tier 4	94.0 Thousand Gals X \$9.36 = 879.84
Sewer	
Sewer Base Charge	53.43
Sewer Charges	132.0 Thousand Gals X \$7.20 = 950.40
Total Current Transactions	2,066.24
TOTAL BALANCE DUE	\$2,066.24

Annual Water Quality Report: The 2025 Consumer Confidence Report is available online at bit.ly/PascoRegional2025. To request a paper copy, please call (813) 929-2733.

Please return this portion with payment



TO PAY ONLINE, VISIT pascoeasypay.pascocountyfl.net

Check this box if entering change of mailing address on back.

Account # 0350545
 Customer # 01289193
 Balance Forward 0.00
 Current Transactions 2,066.24

Total Balance Due	\$2,066.24
Due Date	5/22/2026

10% late fee will be applied if paid after due date

The Total Due will be electronically transferred on 05/22/2026.

WILDERNESS LK PRESER
 250 INTERNATIONAL PARKWAY STE 208
 LAKE MARY FL 32746-5062

PASCO COUNTY UTILITIES
 CUSTOMER INFORMATION & SERVICES
 P.O. BOX 2139
 NEW PORT RICHEY, FL 34656-2139



WASTE CONNECTIONS OF FLORIDA
 PASCO HAULING
 6800 OSTEEN ROAD
 NEW PORT RICHEY, FL 34653-3667
 DISTRICT NO. 6425

ACCOUNT NO. 6425-023988
 INVOICE NO. 8880870W425
 STATEMENT DATE 05/20/26
 DUE DATE 05/25/26
 BILLING PERIOD //--

WILDERNESS LAKE PRESERVE
 250 INTERNATIONAL PKWY STE 208
 LAKE MARY, FL 32746

FOR ASSISTANCE CALL
 Customer Service (727) 847-9100
 Fax (727) 841-8539
 One Time Payments (800) 457-1379

INVOICE STATEMENT

Date	Description	Amount
	Service Location Acct #023988-0001	WILDERNESS LAKE PRESERVE LODGE 21320 WILDERNESS LAKE BLVD LAND
04/21/26	OVERAGES (AI) BOL:	1.00EA ZO 117011326 \$ 110.00
05/20/26	BASIC SERVICE CHARGE 6/1/2026-6/30/2026	1.00 6.00YD \$ 592.30
05/20/26	ADMINISTRATION FEE 6/1/2026-6/30/2026	1.00 6.00YD \$ 6.30
05/20/26	FUEL SURCHARGE	\$ 272.17
05/20/26	ENVIRONMENTAL SURCHARGE	\$ 70.86
	Invoice Total	\$ 1,051.63
	Account Balance	\$ 1,051.63

This invoice is scheduled for automatic payment according to your instructions on our online bill pay portal at myaccount.wcicustomer.com.

****To avoid late fees, payment must be posted to your account within 30 days of your invoice date. ****
 Bank returned checks will be electronically re-presented to your bank and you may be responsible for a resulting processing fee.

Your next invoice may include a rate adjustment. Please contact us if you have any questions or objections.

Please remit to the address below and return your remit stub with your payment.

NNNNNNNNNN



WASTE CONNECTIONS OF FLORIDA
 PASCO HAULING
 6800 OSTEEN ROAD
 NEW PORT RICHEY, FL 34653-3667

ACCOUNT NO. 6425-023988
 INVOICE NO. 8880870W425
 STATEMENT DATE 05/20/26
 DUE DATE 05/25/26
PAY THIS AMOUNT 1,051.63

WRITE AMOUNT PAID	\$
-------------------------	----

WILDERNESS LAKE PRESERVE
 250 INTERNATIONAL PKWY STE 208
 LAKE MARY, FL 32746

MAIL PAYMENT TO:
 WASTE CONNECTIONS OF FLORIDA
 PO BOX 535233
 PITTSBURGH, PA 15253-5233

6425 00000000000000000000X0239888 00000105163000000000000008880870 8



duke-energy.com
877.372.8477

Your Summary Bill

THE PRESERVE WILDERNESS LAKE Bill date May 6, 2026
For service Mar 27 - Apr 27
32 days

Collective account number 9300 0001 3381

If you have questions, you can reach us at collectivebillingdef@duke-energy.com.

Billing summary

Previous Amount Due	\$13,005.08
Payment Received Apr 28	-13,005.08
Current Electric Charges	2,838.02
Current Lighting Charges	9,959.96
Taxes	122.15
Total Amount Due May 27	\$12,930.13

Billing summary by account

Account Number	Service Address	Totals
910089534191	21330 WILDERNESS LAKES BLVD LAND O LAKES FL 34637	285.98
910089556460	21320 WILDERNESS LAKE BLVD LAND O LAKES FL 34637	378.26
910089557198	21326 WILDERNESS LAKES BLVD LAND O LAKES FL 34637	337.29
910089584331	000 WILDERNESS LAKES BLVD LAND O LAKES FL 34639	10,016.81
910089643632	21316 WILDERNESS LAKES BLVD LAND O LAKES FL 34637	1,911.79
	Total Charges	\$12,930.13

Late payments are subject to a 1.0% late charge

Please return this portion with your payment. Thank you for your business.



Duke Energy Return Mail
PO Box 1094
Charlotte, NC 28201-1094

Collective account number
9300 0001 3381

\$12,930.13
by May 27

After 90 days from bill date, a
late charge will apply.

000001 000000009



THE PRESERVE WILDERNESS LAKE
250 INTERNATIONAL PKWY STE 208
LAKE MARY FL 32746-5062



Duke Energy Payment Processing
PO Box 1094
Charlotte, NC 28201-1094

88930000013381000660000000000000000129301300012930132

B:\ef\duke\HA-20260502\1313 38 48-1-00000009



Billing Details

Account Information	Billing Details		Amounts
910089534191 THE PRESERVE WILDERNESS LAKE 21330 WILDERNESS LAKES BLVD LAND O LAKES FL 34637	General Service Demand Sec (GSD-1)		
	Meter Number:	1016103	Customer Charge 18.47
	Bill Period:	Mar 27 - Apr 27	Energy Charge 67.59
	Billed kWh	1,981,590	Fuel Charge 87.63
	Billed Demand kW	8,682	Demand Charge 101.49
Load Factor	29.72	Asset Securitization Charge 3.41	
		Regulatory Assessment Fee 0.24	\$7.39
		Gross Receipts Tax 7.16	
		Total	\$285.98
910089556460 THE PRESERVE WILDERNESS LAKE 21320 WILDERNESS LAKE BLVD LAND O LAKES FL 34637	General Service Demand Sec (GSD-1)		
	Meter Number:	1016104	Customer Charge 18.47
	Bill Period:	Mar 27 - Apr 27	Energy Charge 94.53
	Billed kWh	2,771,166	Fuel Charge 122.54
	Billed Demand kW	10,964	Demand Charge 128.17
Load Factor	32.91	Asset Securitization Charge 4.77	
		Regulatory Assessment Fee 0.32	\$9.78
		Gross Receipts Tax 9.46	
		Total	\$378.26
91008957198 THE PRESERVE WILDERNESS LAKE 21326 WILDERNESS LAKES BLVD LAND O LAKES FL 34637	General Service Demand Sec (GSD-1)		
	Meter Number:	1017034	Customer Charge 18.47
	Bill Period:	Mar 27 - Apr 27	Energy Charge 62.64
	Billed kWh	1,836,523	Fuel Charge 81.21
	Billed Demand kW	13,952	Demand Charge 163.09
Load Factor	17.14	Asset Securitization Charge 3.16	
		Regulatory Assessment Fee 0.29	\$8.72
		Gross Receipts Tax 8.43	
		Total	\$337.29
910089584331 THE PRESERVE WILDERNESS LAKE 000 WILDERNESS LAKES BLVD LAND O LAKES FL 34639	Lighting Service Company Owned/ Maintained (LS-1)		
	Bill Period:	Mar 27 - Apr 27	Customer Charge 1.92
	30W LED TWN & CTRY	284	Energy Charge 726.23
	3K BLK		Fuel Charge 749.98
	Monticello Black TIII	70	Asset Securitization Charge 9.36
	3000K		SV MONTICELLO 9500L 1,649.91
	49W TRADITIONAL	34	SV SAL 9500 1,478.74
	LED		49W TRADITIONAL LED 14.44
	49W TRADITIONAL	51	49W TRADITIONAL LED 20.85
	LED		49w LED TrdCo 3000K 24.15
	50 DTRAD BLK III 3K	34	Monticello Black TIII 3000K 65.36
	49w LED TrdCo 3000K	51	30W LED TWN & CTRY 3K 185.22
	30 OTC BLK III 3K	10	BLK
	SV MONTICELLO	6,321	50 DTRAD BLK III 3K 16.64
	9500L		30 OTC BLK III 3K 6.75
	SV SAL 9500	10,486	Monticello Black TIII 3000K 8.16
			30W LED TWN & CTRY 3K 55.08
		BLK	
		50 DTRAD BLK III 3K 4.08	
		30 OTC BLK III 3K 2.04	
		Total	\$9,969.96

In the future, please call 1-888-800-5773, 360-463-3000 or 1-800-000-0000





Account Information	Billing Details		Amounts
		49w LED Trd/Ola 3000K	6.12
		49W TRADITIONAL LED	6.12
		49W TRADITIONAL LED	4.08
		SV SAL 9500	518.46
		SV MONTICELLO 9500L	370.23
		16 SMOOTH DEC CNCRT/ COLONIAL	2,467.08
		16 DECORATIVE CONCRETE-VIC II	1,478.96
		Regulatory Assessment Fee	8.68
		Gross Receipts Tax	38.17
		Total	\$10,016.81
910089643632 THE PRESERVE WILDERNESS LAKE 21316 WILDERNESS LAKES BLVD LAND O LAKES FL 34637	General Service Demand Time of Use Sec (GSST-1) Meter Number: 9504085 Bill Period: Mar 27 - Apr 27 Billed kWh 17,151,340 Billed kWh On Peak 2,163,720 Billed kWh Off Peak 1,946,060 Billed kWh Discount 3,051,560 Monthly Max Demand 42,040 Billed Demand kW 47,000 Billed Demand kW On Peak 41,800 Billed Demand kW Mid Pk 42,040 Load Factor 53.12	Customer Charge Energy Charge Discount Energy Charge On Peak Energy Charge Off Peak Fuel Charge On Peak Fuel Charge Off Peak Fuel Charge Discount Demand Charge Base Demand Charge On Peak Demand Charge Mid Peak Demand Charge Monthly Max Asset Securitization Charge	18.47 63.11 87.90 362.32 108.48 524.07 123.74 172.07 91.96 167.32 153.44 29.50
		Regulatory Assessment Fee	1.62
		Gross Receipts Tax	47.79
		Total	\$1,911.79
		Total Amount Due	\$12,930.13

Evolve: Duke Bill, 2024/05/27 11:58 AM, 4-010000000



duke-energy.com
877.372.8477

Your Energy Bill

Service address

THE PRESERVE WILDERNESS LAKE
7973 CITRUS BLOSSOM DR
HERONS GLEN

Bill date May 6, 2026
For service Apr 3 - May 4
32 days

Account number **9100 8746 4930**

Billing summary

Previous Amount Due	\$30.80
<i>Payment Received Apr 28</i>	-30.80
Current Electric Charges	30.00
Taxes	0.80
Total Amount Due May 27	\$30.80



Thank you for your payment.

Duke Energy Florida utilized fuel in the following proportions to generate your power: Coal 10.9%, Purchased Power 2%, Gas 78.9%, Oil 0.1%, Nuclear 0%, Solar 8.1% (For prior 12 months ending March 31, 2026).

Your usage snapshot

Electric usage history

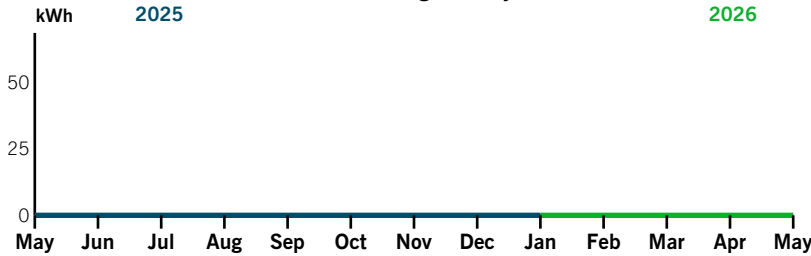

Average temperature in degrees

81° 82° 84° 84° 81° 75° 67° 65° 60° 60° 71° 74° 79°

	Current Month	May 2025	12-Month Usage	Avg Monthly Usage
Electric (kWh)	0	0	N/A	0
Avg. Daily (kWh)	0	0	N/A	

12-month usage based on most recent history

Mail your payment at least 7 days before the due date or pay instantly at duke-energy.com/billing. Payments for this statement within 90 days from the bill date will avoid a 1.0% late payment charge.

Please return this portion with your payment. Thank you for your business.

Amount of automatic draft



Account number
9100 8746 4930

\$30.80
by May 27

After 90 days from bill date, a late charge will apply.

Duke Energy Return Mail
PO Box 1090
Charlotte, NC 28201-1090

\$ _____ \$ _____
Add here, to help others with a contribution to Share the Light **Amount enclosed**

THE PRESERVE WILDERNESS LAKE
250 INTERNATIONAL PKWY STE 208
LAKE MARY FL 32746

Duke Energy Payment Processing
PO Box 1094
Charlotte, NC 28201-1094



Your usage snapshot - Continued

Current electric usage for meter number 4426448	
Actual reading on May 4	477
Previous reading on Apr 3	- 477
<hr/>	
Energy Used	0 kWh
Billed kWh	0.000 kWh



A kilowatt-hour (kWh) is a measure of the energy used by a 1,000-watt appliance in one hour. A 10-watt LED lightbulb would take 100 hours to use 1 kWh.

Billing details - Electric

Billing Period - Apr 03 26 to May 04 26	
Meter - 4426448	
Customer Charge	\$17.92
Minimum Bill Adjustment	12.08
<hr/>	
Total Current Charges	\$30.00

The total charges incurred during this billing period are below the minimum expenses necessary to equitably provide and maintain reliable electric service to all facilities across the state. When the combined monthly customer, energy, fuel, and other charges fall below a \$30 threshold, customers will see the difference noted as a Minimum Bill Adjustment under the Billing Details section. Learn more about the minimum charge adjustment and additional customer charges at duke-energy.com/minimum.

Your current rate is General Service Non-Demand Sec (GS-1).

For a complete listing of all Florida rates and riders, visit duke-energy.com/rates

Billing details - Taxes

Regulatory Assessment Fee	\$0.03
Gross Receipts Tax	0.77
<hr/>	
Total Taxes	\$0.80

Invoice

A TOTAL SOLUTION, INC. (ATS)
 Security & Fire
 3487 Keystone Road
 Tarpon Springs, FL 34688

DATE	INVOICE #
5/1/2026	000203001

BILL TO: (Attention Accounts Payable)
Wilderness Lake Preserve C/o Vesta District Services 250 International Pkwy., Ste208 Lake Mary, FL 32746

SHIP TO:
Wilderness Lake Preserve 21316 Wilderness Lake Blvd Land O Lakes, FL 33543

P.O. NO.	TERMS	DUE DATE	REP	JOB DATA	Federal ID Number	SERVICE DATE
	Net 15	5/16/2026	Rober			

ITEM	DESCRIPTION	QTY	RATE	AMOUNT
Labor SVC R...	Monthly Maintenance Agreement Monthly service charge for annual Fire Alarm inspections, Fire Sprinkler inspections and biennial smoke detector sensitivity test.	1	600.00	600.00
	Annual fire alarm inspection			
	Annual sprinkler inspection			
	Annual fire extinguisher inspection			
	Annual Fire Security Alarm monitoring with 24 hr testing #0101-7599 Digicom			
	Replacement of batteries for the fire/security alarm system, access control system, and power supplies			
	Technical support on all systems 24/7			
	Service calls			

All monitoring is billed and due in advance and the schedule is as follows: 1st Quarter=January, February, March 2nd Quarter=April, May June 3rd Quarter=July, August, September 4th Quarter=October, November, December All cancellations MUST be in writing 30 days prior to cancellation!! Past due accounts are subject to a 1.5% interest charge per month. If you pay by Credit Card and cancel payment you are responsible for all charge back fees. Returned Item Fee of \$35.00.	Subtotal
	Sales Tax (0.0%)
	Total
	Balance Due

Phone #	Web Site	Fax #	E-mail
727-942-1993	www.atotalsolution.com	727-943-5919	accountsreceivable@atotalsolution.com

Invoice

A TOTAL SOLUTION, INC. (ATS)
 Security & Fire
 3487 Keystone Road
 Tarpon Springs, FL 34688

DATE	INVOICE #
5/1/2026	000203001

BILL TO: (Attention Accounts Payable)
Wilderness Lake Preserve C/o Vesta District Services 250 International Pkwy.,Ste208 Lake Mary, FL 32746

SHIP TO:
Wilderness Lake Preserve 21316 Wilderness Lake Blvd Land O Lakes, FL 33543

P.O. NO.	TERMS	DUE DATE	REP	JOB DATA	Federal ID Number	SERVICE DATE
	Net 15	5/16/2026	Rober			

ITEM	DESCRIPTION	QTY	RATE	AMOUNT
	Technician labor for all systems under service contract Technician labor for emergency calls (after hours, weekends and holidays) for all systems under service contract.			

All monitoring is billed and due in advance and the schedule is as follows: 1st Quarter=January, February, March 2nd Quarter=April, May June 3rd Quarter=July, August, September 4th Quarter=October, November, December All cancellations MUST be in writing 30 days prior to cancellation!! Past due accounts are subject to a 1.5% interest charge per month. If you pay by Credit Card and cancel payment you are responsible for all charge back fees. Returned Item Fee of \$35.00.	Subtotal	\$600.00
	Sales Tax (0.0%)	\$0.00
	Total	\$600.00
	Balance Due	\$600.00

Phone #	Web Site	Fax #	E-mail
727-942-1993	www.atotalsolution.com	727-943-5919	accountsreceivable@atotalsolution.com



Pasco Sheriff's Office
 ATTN: Extra Duty
 7432 Little Road
 New Port Richey, FL 34654

Invoice: I-20264-12722
Service Total: \$2200.00
Payments Total:
Amount Due: \$2200.00
Sent Date: 4/27/2026
Payment Terms: Due upon receipt

THE PRESERVE AT WILDERNESS LAKE CDD
 21320 WILDERNESS LAKE BLVD.
 LAND O'LAKES, FL 34637

Service Date	Employee	Job Name	Start Time	Hrs Wrkd	Billed Rate	Emp Fees
4/1/2026	MERCADO MARIN, GEORGE - 7821	THE PRESERVE AT WL CDD* Community (Security)	9:00 PM	4.00	\$60.00	\$240.00
4/2/2026	SCARANGELLA, ANTHONY - 7727	THE PRESERVE AT WL CDD* Community (Security)	10:00 PM	4.00	\$60.00	\$240.00
4/3/2026	FRANCIS, DAVID - 7459	THE PRESERVE AT WL CDD* Community (Security)	10:00 PM	4.00	\$70.00	\$280.00
4/4/2026	VANCE, NICHOLAS - 7658	THE PRESERVE AT WL CDD* Community (Security)	10:00 PM	4.00	\$60.00	\$240.00
4/10/2026	MYERS, BRAYDEN - 7618	THE PRESERVE AT WL CDD* Community (Security)	9:00 PM	4.00	\$60.00	\$240.00
4/11/2026	KANOS, NICHOLAS - 7617	THE PRESERVE AT WL CDD* Community (Security)	11:00 PM	4.00	\$60.00	\$240.00
4/17/2026	VOROS, PETER - 7761	THE PRESERVE AT WL CDD* Community (Security)	10:00 PM	4.00	\$60.00	\$240.00
4/18/2026	Not Filled	THE PRESERVE AT WL CDD* Community (Security)		0.00	\$0.00	\$0.00
4/24/2026	WALKER, KAYLEE - 5612	THE PRESERVE AT WL CDD* Community (Security)	9:00 PM	4.00	\$60.00	\$240.00
4/25/2026	CHRISTENSEN, CALEB - 7828	THE PRESERVE AT WL CDD* Community (Security)	10:00 PM	4.00	\$60.00	\$240.00
					Total:	\$2200.00

Questions regarding Invoice Charges & Payments please contact:

Contact: Pasco Sheriff's Office
Telephone: 727-844-7795
Email: ExtraDuty@pascosheriff.org

Make Checks Payable To:

Invoice #: I-20264-12722

Pasco Sheriff's Office

Invoice Total: \$2200.00

Invoice For: THE PRESERVE AT WILDERNESS
LAKE CDD

Mail Checks To:

Pasco Sheriff's Office

ATTN: Extra Duty Program

7432 Little Road New Port Richey, Florida 34654

Payment Terms: Due upon receipt

Please include Invoice # in check comment

How To Pay Online

Customers who wish to make payments to the Pasco Sheriff's Extra Duty Office may do so on the AllPaid Payment Platform. Cardholders can now make payments with Visa®, MasterCard®, American Express® and Discover® (service charges apply). To make an online payment via the AllPaid platform, please visit <https://allpaid.com/plc/a005v9>.

Late Payments

Unpaid invoices over 30 days from the date of invoice are considered late payments and may be subject to legal action, including collections. Extra Duty Employers are responsible for the cost of attorney's fees, court fees and/or collection's fees as a result of any legal action. In addition, a late fee penalty may be implemented at the rate of 2% of the total invoice added per day.



McNatt Plumbing Company, LLC
 5800 E. Broadway Ave.
 Tampa, FL 33619
 813-971-6100
 CFC045185

Invoice 45411590
 Invoice Date 4/30/2026
 Completed Date 4/30/2026
 Customer PO
 Payment Term Due Upon Receipt

Billing Address

WILDERNESS LAKES PRESERVE
 21320 Wilderness Lake Boulevard
 Land O Lakes, FL 34637 USA

Job Address

WILDERNESS LAKES PRESERVE
 21320 Wilderness Lake Boulevard
 Land O Lakes, FL 34637 USA

Description of work

Women's locker room has a faucet that is loose and leaking. Hardware underneath cabinet completely rusted out. Installed new washer and nuts underneath after removing old. Was able to tighten down and secure properly. Tested by running fixture everything working properly at

Task #	Description	Quantity	Price	Total
PLUMB2018	Includes labor and material	1.00	\$185.00	\$185.00

Sub-Total \$185.00
Tax \$0.00
Total Due \$185.00
Payment \$0.00

Balance Due \$185.00

Thank you for your business!

I authorize McNatt Plumbing Company, Inc. to proceed with the work specified above for a total of \$185.00

4/30/2026

I acknowledge that I have examined the finished work and authorized its completion.

4/30/2026







FOR CALIFORNIA RESIDENTS
DP65 POUR LES RESIDENTS
ATENCIÓN PARA LOS
RESIDENTES DE CALIFORNIA
NEWPORT NEWS, VA 23609





20108 Pond Spring Way
Tampa, FL 33647
813-991-6069
romanergraphics@gmail.com

INVOICE # 23078

TO: Wilderness Lake Preserve
COMPANY NAME:
DATE: 4/22/26

Installation of speaker in Activity Center.	
Troubleshoot and rewire chandelier in Activity Center.	

TOTAL: \$650.00

ROMANER GRAPHICS
Thank You,

Himes Electrical Service, Inc.

Invoice

P. O. Box 516
Lutz, Florida 33548

Date	Invoice
5/1/2026	25495

Bill To
Vesta District Services 250 International Parkway Suite 208 Lake Mary, FL 32746

Ship To
Preserve at Wilderness Lakes 21320 Wilderness Lake Blvd. LOL, FL

Work Order	Purchase Order	Terms	Due Date	Rep
13815		Net 30	5/31/2026	JKH

Quantity	Description	Rate	Amount
1	Service Call 4/29	45.00	45.00
1.25	Electrician	95.00	118.75
	Checked contactor for the splash pad. Contactor working fine - 1 of the motors is bad.		

Thank you for your business.

Total	\$163.75
Payments/Credits	\$0.00
Balance Due	\$163.75

Phone #	Fax #
813-909-1927	813-909-9776

INVOICE

RedTree Landscape Systems
5532 Auld Lane
Holiday, FL 34690

service@redtreelandscape.systems
+1 (888) 733-8799
redtreelandscapesystems.com



Bill to

The Preserve at Wilderness Lake CDD
250 International Parkway
Suite 208
Lake Mary, FL 32746 USA

Ship to

The Preserve at Wilderness Lake CDD
21320 Wilderness Lake Blvd
Land O' Lakes, FL 34637 USA

Invoice details

Invoice no.: 33907
Terms: Net 45
Invoice date: 04/20/2026
Due date: 06/04/2026

#	Date	Product or service	Description	Qty	Rate	Amount
1.			Irrigation repairs were performed as follows on 4.8.26 Water Edge Timer Replaced a broken spray head on zone 13.			
2.		Sales	6" spray head	1	\$21.56	\$21.56
3.		Sales	labor-technician	0.15	\$65.00	\$9.75
					Total	\$31.31

INVOICE

RedTree Landscape Systems
5532 Auld Lane
Holiday, FL 34690

service@redtreelandscape.systems
+1 (888) 733-8799
redtreelandscapesystems.com



Bill to

The Preserve at Wilderness Lake CDD
250 International Parkway
Suite 208
Lake Mary, FL 32746 USA

Ship to

The Preserve at Wilderness Lake CDD
21320 Wilderness Lake Blvd
Land O' Lakes, FL 34637 USA

Invoice details

Invoice no.: 33915
Terms: Net 45
Invoice date: 04/20/2026
Due date: 06/04/2026

#	Date	Product or service	Description	Qty	Rate	Amount
1.			Irrigation repairs were performed as follows on 4.8.26 The Lodge Replaced a bad solenoid on zone 10.			
2.		Sales	Solenoid	1	\$84.25	\$84.25
3.		Sales	labor-technician	3	\$65.00	\$195.00
					Total	\$279.25

RedTree Landscape Systems

5532 Auld Lane

Holiday, FL 34690

+18887338799

service@redtreelandscape.systems

redtreelandscapesystems.com

Invoice 34062



BILL TO

The Preserve at Wilderness Lake CDD
250 International Parkway Ste 208
Lake Mary, FL. 32746

DATE 05/01/2026	PLEASE PAY \$15,000.00	DUE DATE 06/15/2026
---------------------------	----------------------------------	-------------------------------

ACTIVITY	QTY	RATE	AMOUNT
Grounds Maintenance Monthly Grounds Maintenance	1	12,900.00	12,900.00
Irrigation:Irrigation Irrigation System Inspection	1	1,100.00	1,100.00
Arbor Care Monthly Hardwood Tree Pruning	1	1,000.00	1,000.00

For the service month of this billing, kindly refer to the date on the invoice. Thank you!

TOTAL DUE	\$15,000.00
------------------	--------------------

THANK YOU.



DCSI, Inc. "Security & Sound"
 P.O. Box 265
 Lutz, FL 33548 USA
 813-949-6500
 info@dcsisecurity.com
 http://DCSIsecurity.com

Invoice

BILL TO
Wilderness Lake Lodge 250 International Parkway Suite 208 Lake Mary, FL 32746

SHIP TO
Wilderness Lake Lodge 21320 Wilderness Lake Boulevard Land O' Lakes, Florida 34637

INVOICE #	DATE	TOTAL DUE	DUE DATE	TERMS	ENCLOSED
35080	04/22/2026	\$670.00	05/07/2026	Net 15	

P.O. NUMBER
11310

SALES REP
Tech: DC

DATE	ACTIVITY	QTY	RATE	AMOUNT
03/20/2026	Service:Reg. Reason for call: 1. Drop off 100 access cards. 2. Check Hikvision hard drive error message - not recording. Tech notes: 1. Dropped off 100 access cards. 2. Tested HDD #2 and it would not format. Opened the DVR and disconnected HDD #2. HDD #1 is working properly. Need to order a replacement for HDD #2.	1	145.00	145.00
03/20/2026	Access Control Cards 1326LGSMV 26bit ProxCard II Clamshell Access Cards Card #'s: 13600-13699 FC: 162	100	5.25	525.00

Thank you for choosing DCSI, Inc as your "Security & Sound" company!
 *ALL SYSTEMS COME WITH 90 DAYS WARRANTY ON LABOR AND ONE YEAR WARRANTY ON PARTS, UNLESS OTHERWISE NOTED.
 **Returned Checks will receive \$25 NSF Fee.
 ***Late Fees are 1.5% per month

SUBTOTAL	670.00
TAX (0.075)	0.00
TOTAL	670.00
BALANCE DUE	\$670.00

Purchase Order# TREND RENEWAL**Invoice****Vendor:**

CDW Government LLC
 200 N. Milwaukee Ave
 Vernon Hills, IL 60061
 Toll-Free: 800.800.4239

Bill to:

Customer Name THE PRESERVE AT
WILDERNESS LAKE CDC

Address 21320 WILDERNESS LAKE BLVD

City, State, Zip LAND O LAKES, FL 34637-7879

Phone # (813) 995-2437

Ship to:

Customer Name THE PRESERVE AT
WILDERNESS LAKE CDC

Address 21320 WILDERNESS LAKE BLVD

City, State, Zip LAND O LAKES, FL 34637-7879

Phone # (813) 995-2437

Qty.	CDW Part #	Description	Unit Price	Total
9	1976874	TREND WF SEC SVC MNT 2-25	\$33.50	\$301.50

Notes/RemarksSubtotal \$301.50Shipping \$0.00Taxes (if applicable) \$0.00**Net 30 Payment Terms**Total \$301.50Print Name: Tish DobsonSignature Required: *Tish Dobson*Date: 4-22-2026



Arrow Exterminators Inc
 417 Market St, Suite A
 Bushnell, FL 33513
 352-399-8408

Service Slip/Invoice

INVOICE: 66908282
DATE: 04/17/2026
ORDER: 66908282

Bill To: [2490898]
 The Preserve Wilderness Lake
 C/o Vesta District Services
 250 International Pkwy
 Suite 208
 Lake Mary, FL 32746-5030

Work Location: [2490898] 813-995-2437
 Wilderness Lake Lodge
 21320 Wilderness Lake Blvd
 Land O' Lakes, FL 34637-7879

Work Date	Time	Target Pest	Technician	Time In
04/17/2026	04:02 AM		ZTHISSELL	Zachary Thissell
Purchase Order	Terms	Last Service	Map Code	Time Out
		04/17/2026		Lic:JE334251

Service	Description	Price
---------	-------------	-------

CPC-ONE TIME	Pest Control Service	\$1,185.00
Yearly treatment of parks Fox Grove, Stone Leigh, Whisper Wind, and Oakhurst for ant treatment. Yearly treatment of areas around lodge and pool deck as well for ant activity.		SUBTOTAL \$1,185.00 TAX \$0.00 AMT. PAID \$0.00 TOTAL \$1,185.00
Serviced parks and acreage around main lodge to reduce fire and nuisance ants. Treated Fox Grove, Whispering Wind, Stone Leigh, Oakhurst, and around Lodge and pool with residual bait to reduce ant activity. Thank you Zach		
Exterior Applications (baits) - Do not allow grazing of feed, lawn, or sod clippings by livestock after bait a		AMOUNT DUE \$1,185.00

TECHNICIAN SIGNATURE

CUSTOMER SIGNATURE

* Balances outstanding over 30 days from the date of service may be subject to a late fee of the lesser of 1.5% per month (18% per year) or the maximum allowed by law.
 Customer agrees to pay accrued expenses in the event of collection.

I hereby acknowledge the satisfactory completion of all services rendered, and agree to pay the cost of services as specified above.

PLEASE PAY FROM THIS INVOICE

Cooper Pools Inc

4850 Allen Rd PMB 13
Zephyrhills, FL, 33541
(844) 766-5256

Invoice #: 1530

Invoice Date: 4/22/2026

Due Date: 5/22/2026

Bill To: Wilderness Lake Preserve

Wilderness Lake Preserve 250 International Pkwy #208
Lake Mary, FL 32746

LOCATION: 21320 Wilderness Lake Blvd, Land O' Lakes

Item	Description	Qty	Rate	Amount
SR Smith Lift Operator Battery	SR Smith Lift Operator Battery	1.00	\$547.22	\$547.22

Additional ADA battery delivered to property manager.

Subtotal: \$547.22

Tax: \$0.00

Total: \$547.22

Amount Due: \$547.22



Fitness Logic

380 Scarlet Blvd
Oldsmar, FL 34677

Phone #
727-784-4964

Fax #
727-784-0223

E-mail
fitlogic@aol.com

Invoice

Date	Invoice #
4/29/2026	129573

Bill To
Preserve at Wilderness Lake 21320 Wilderness Lake Boulevard Land O' Lakes, FL 34637

Location/Contact/Phone
Preserve at Wilderness Lake 21320 Wilderness Lake Boulevard Land O' Lakes, FL 34637 813-995-2437

P.O. Number	Terms	Rep	Work Order #	Completed
	Net 10	JRZ	18786	4/29/2026

Item Code	Description	Quantity	Price Each	Amount
Maintenance	Monthly General Maintenance and cleaning of all equipment - Labor Only Maintenance completion during April.	1	125.00	125.00

Thank you for your business. Invoices over 30 Days will incur 1.5% Interest per month	Subtotal	\$125.00
	Sales Tax (0.0%)	\$0.00
	Total	\$125.00

PALM BEACH SECURITY & SAFE INC

Invoice

PBSS DOORS & HARDWARE
 7113 PALISADE DR.
 Port Richey, Fl. 34668
 PH:727-789-6000 FX:727-815-9787

Date	Invoice #
4/28/2026	12874

Bill To
WILDERNESS LAKE PRESERVE 21320 BLVD. LAND O LAKES, FL. 34637 813-995-2437-OFFICE

Performed
W/O TISH 813-758-4841 CELL TDOBSON@VESTAPROPERTYSERVICES.COM

P.O. No.	Technician	Project
	RJ	

Description	Qty	Rate	Amount
FITNESS CENTER / RHOS EMERGENCY EXIT DOOR WOULDN'T OPEN TORE DOWN CVR PANIC DEVICE & SERVICED IT AND THE LOCKING RODS LODGE / RHOS DOOR FACING LAKE - ADJUSTED DOOR CLOSER IMMEDIATE VIP SERVICE, SUPPLIES, EQUIPMENT & LABOR		522.00	522.00

Subtotal		\$522.00
Sales Tax (0.07%)		\$0.00
Total		\$522.00
Payments/Credits		\$0.00
Balance Due		\$522.00

Please Note:
 All sales are final
 Make checks payable to: PBSS
 M/C, Visa & AMX accepted W/4% FEE added
 We do not offer 30 accounts, all invoices are due upon
 receipt. Finance charges & monthly late fees will be
 applied to all balances over 30 days old. Thank-you



7823 N Dale Mabry Hwy,
 STE 107
 Tampa, FL 33614
 Ofc: 813-870-2966
 Fax: 813-870-2896

Invoice

Date	Invoice #
5/7/2026	38644

Bill To
Wilderness Lake Preserve Tish Dobson 21320 Wilderness Lake Blvd Land O Lakes, FL 34637

Ship To
Wilderness Lake Preserve Tish Dobson 21320 Wilderness Lake Blvd Land O Lakes, FL 34637

P.O. No.	Terms	Rep
	50% Down/50% De...	TJ

Item	Description	Qty	Rate	Amount
PHRCT631BG30...	TRM 631 Treadmill	2	6,547.70	13,095.40T
Freight	Shipping and Handling	1	500.00	500.00
Installation P&L	Installation - Includes Removal of 2 Old TRMS	1	900.00	900.00T

Subtotal		\$14,495.40
Sales Tax (0.0%)		\$0.00
Total		\$14,495.40
Payments/Credits		\$0.00
Balance Due		\$14,495.40

Thank you for your order. We look forward to working with you in the future. If you have any questions or needs feel free to call us at 888-826-7867.

Invoices are considered delinquent thirty (30) days from the invoice date. Interest shall accrue on all past due invoices at the rate of 1.5% per month, or the maximum rate allowable by law, and the client agrees to be liable for all costs related to collection of delinquent invoices, including court costs and attorney's fees.



Invoice

Vesta Property Services, Inc.
245 Riverside Avenue
Suite 300
Jacksonville FL 32202

Invoice # 432291
Date 04/30/2026
Terms Net 30
Due Date 05/30/2026
Memo

Bill To
The Preserve @ Wilderness Lake Community Developm...
250 International Parkway Suite 280
Lake Mary FL 3274

Description	Quantity	Rate	Amount
General Management & Oversight	1	4,635.00	4,635.00
Gross Wages Apri 2026 + burden	1	27,756.50	27,756.50
GM Wages April 2026 + burden	1	8,115.38	8,115.38
Qwick Temp Labor April 2026	1	408.40	408.40

Thank you for your business.

Total 40,915.28

INVOICE

Cooper Pools Inc CPC1459240
4850 Allen Rd PMB 13
Zephyrhills, FL 33541-3551

info@cooperpoolsinc.com
+1 (844) 766-5256



Cleaning Commercial Acct:Vesta Property Services:Wilderness Lake Preserve

Bill to

Wilderness Lake Preserve
245 Riverside Ave Suite 300
Jacksonville, FL 32202

Ship to

Wilderness Lake Preserve
21320 Wilderness Lake Blvd
Land O' Lakes, FL 34637

Invoice details

Invoice no.: 2026-1440
Terms: Net 30
Invoice date: 05/01/2026
Due date: 05/31/2026

#	Date	Product or service	Description	Qty	Rate	Amount
1.		Monthly Commercial Maintenance	Monthly Commercial Maintenance May 2026	1	\$6,438.50	\$6,438.50

Total **\$6,438.50**

Ways to pay



[View and pay](#)



4740B Allen Rd PMB
Zephyrhills, FL 33541

www.cooperpoolsinc.com

EIN 27-1602937
License # CPC1459240

Wilderness Lake Preserve
21320 Wilderness Lake Boulevard
Land O' Lakes FL 34637

PLEASE PAY BY	AMOUNT	INVOICE DATE
05/31/2026	\$1,094.39	05/01/2026

INVOICE NO. 731

Order No.: 889
Quote No.: 889
Job No.: 1318
Site Address: 21320 Wilderness Lake
 Boulevard
 Land O' Lakes FL 34637

Splash Pad Motor Replacement. Check spa feature breaker- tech reports it is loud.

Commercial Installation / Repairs

Item	Quantity	Unit Price	Total
USQ1202 2HP 230V EE UR 48Y ODP SQFL MOTOR	1.00	\$604.43	\$604.43
GO-KIT79V-9 VITON STA-RITE MAX-E-PRO PUMP SEAL KIT	1.00	\$46.46	\$46.46
C19-37AZ MAX-E-PRO TANK CLAMP BAND	1.00	\$173.50	\$173.50
Commercial installation / Labor			\$270.00
Sub-Total ex Tax			\$1,094.39
Tax			\$0.00
Total			\$1,094.39

Sub-Total ex Tax	\$1,094.39
Tax	\$0.00
Total inc Tax	\$1,094.39
Amount Applied	\$0.00
Balance Due	\$1,094.39

How To Pay

INVOICE NO. 731



Credit Card (MasterCard or Visa)

Pay Online cooperpoolsinc.simprosuite.com/payment/
 Please call 844-766-5256 to pay over the phone.



Direct Deposit

Bank **PNC Bank**
 Acc. Name **6768**
 Routing Number **267084199**
 Acc. No. **1241206768**

DUE DATE:	05/31/2026	AMOUNT DUE:	\$1,094.39
------------------	-------------------	--------------------	-------------------





USE COPPER
CONDUCTORS ONLY

WARNING
This tool is designed for use with copper conductors only. Use with other materials may damage the tool and void the warranty. Always use proper safety practices when working with electrical equipment.

TYPE	MAX
MAX. AMP	15
MAX. WIRE GAUGE	12
MAX. WIRE SIZE	12
MAX. WIRE LENGTH	12
MAX. WIRE WEIGHT	12
MAX. WIRE DIAMETER	12
MAX. WIRE AREA	12
MAX. WIRE PERMITS	12
MAX. WIRE PROJECT	12
MAX. WIRE LENGTH	12
MAX. WIRE WEIGHT	12
MAX. WIRE DIAMETER	12
MAX. WIRE AREA	12
MAX. WIRE PERMITS	12
MAX. WIRE PROJECT	12

Motor type is NOT ALLOWED
Use of insulation on
wires must be checked
before use.

ENERGY
CONSERVATION

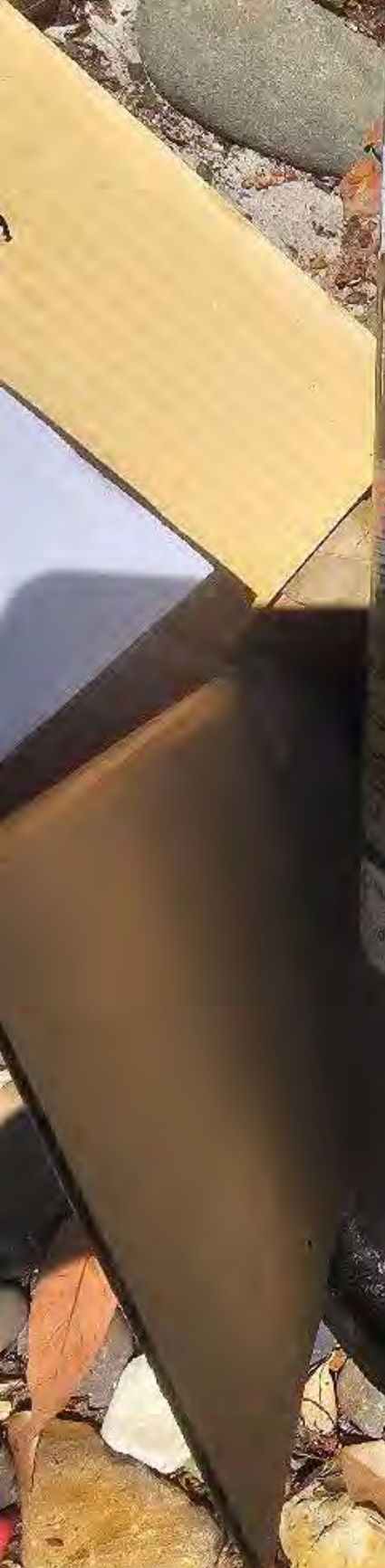



INVOICE

80602

McNatt's Cleaners
6210 N Florida Ave
Tampa, FL 33604
(813) 237-8861

Page: 1
Closing Date: 05/01/2026
Due Date: 05/25/2026
Balance Due: 60.80
Account #: MC12927

The Preserve At Wilderness Lake
c/o Vesta District Services
250 International Pkwy., Suite 208
Lake Mary, FL 32746

Remit To: McNatt's Cleaners
6210 N Florida Ave
Tampa, FL 33604

DATE	REFERENCE	DESCRIPTION	AMOUNT
		The Preserve at Wilderness Lake	
04/06/26	MU-03-882031	Laundry	19.00
04/13/26	MU-04-880179	Laundry	19.00
04/29/26	MU-04-882401	Laundry	22.80
		Subtotal:	60.80

* indicates a paid invoice

TOTAL DUE

60.80

PALM BEACH SECURITY & SAFE INC

Invoice

PBSS DOORS & HARDWARE

7113 PALISADE DR.

Port Richey, Fl. 34668

PH:727-789-6000 FX:727-815-9787

Date	Invoice #
5/4/2026	12881

Bill To
WILDERNESS LAKE PRESERVE 21320 BLVD. LAND O LAKES, FL. 34637 813-995-2437-OFFICE

Performed
W/O TISH 813-758-4841 CELL TDOBSON@VESTAPROPERTYSERVICES.COM

P.O. No.	Technician	Project
	RJ	

Description	Qty	Rate	Amount
LADIES ROOM TO POOL LHOS 3080 REGENT DOOR - BAD DOGGING UNIT - TORE DOWN BAR SERVICED & REPLACED BAD DOGGING UNIT - SITE SERVICE, EQUIPMENT, MATERIALS & LABOR VIP NET	1	476.00	476.00T

Subtotal	\$476.00
Sales Tax (0.07%)	\$0.33
Total	\$476.33
Payments/Credits	\$0.00
Balance Due	\$476.33

Please Note:
 All sales are final
 Make checks payable to: PBSS
 M/C, Visa & AMX accepted W/4% FEE added
 We do not offer 30 accounts, all invoices are due upon receipt. Finance charges & monthly late fees will be applied to all balances over 30 days old. Thank-you

Himes Electrical Service, Inc.

Invoice

P. O. Box 516
Lutz, Florida 33548

Date	Invoice
3/18/2026	25391

Bill To
Vesta District Services 250 International Parkway Suite 208 Lake Mary, FL 32746

Ship To
Preserve at Wilderness Lakes 21320 Wilderness Lake Blvd. LOL, FL

Work Order	Purchase Order	Terms	Due Date	Rep
13716		Net 30	4/17/2026	JKH

Quantity	Description	Rate	Amount
1	Service Call 3/11	45.00	45.00
1	Electrician	95.00	95.00
	Removed burnt contactor for splash pad. Moved wires to extra terminals on other contactor. Control box has good voltage but the relays are not working. Pool company will repair relays.		

Thank you for your business.	Total	\$140.00
	Payments/Credits	\$0.00
	Balance Due	\$140.00

Phone #	Fax #
813-909-1927	813-909-9776

INVOICE

RedTree Landscape Systems
5532 Auld Lane
Holiday, FL 34690

service@redtreelandscape.systems
+1 (888) 733-8799
redtreelandscapesystems.com



Bill to

The Preserve at Wilderness Lake CDD
250 International Parkway
Suite 208
Lake Mary, FL 32746 USA

Ship to

The Preserve at Wilderness Lake CDD
21320 Wilderness Lake Blvd
Land O' Lakes, FL 34637 USA

Invoice details

Invoice no.: 34077
Terms: Net 45
Invoice date: 05/05/2026
Due date: 06/19/2026

#	Date	Product or service	Description	Qty	Rate	Amount
1.		Sales	PINE TREE REMOVAL FROM APPROVED PROPOSAL: 7550 Grasmere Drive. Scope of Work: Flush cut and removal of a pine tree at 7550 Grasmere Drive. *Includes all labor, hauling, and dumping fees.	1	\$500.00	\$500.00
					Total	\$500.00

INVOICE

RedTree Landscape Systems
5532 Auld Lane
Holiday, FL 34690

service@redtreelandscape.systems
+1 (888) 733-8799
redtreelandscapesystems.com



Bill to

The Preserve at Wilderness Lake CDD
250 International Parkway
Suite 208
Lake Mary, FL 32746 USA

Ship to

The Preserve at Wilderness Lake CDD
21320 Wilderness Lake Blvd
Land O' Lakes, FL 34637 USA

Invoice details

Invoice no.: 34078
Terms: Net 45
Invoice date: 05/05/2026
Due date: 06/19/2026

#	Date	Product or service	Description	Qty	Rate	Amount
1.		Sales	PINE TREE REMOVAL FROM APPROVED PROPOSAL: 7919 Citrus Blossom Drive. Scope of Work: *Flush cut and removal of two pine trees at 7919 Citrus Blossom Drive. *Includes all labor, hauling, and dumping fees.	1	\$800.00	\$800.00
					Total	\$800.00

INVOICE

RedTree Landscape Systems
5532 Auld Lane
Holiday, FL 34690

service@redtreelandscape.systems
+1 (888) 733-8799
redtreelandscapesystems.com



Bill to

The Preserve at Wilderness Lake CDD
250 International Parkway
Suite 208
Lake Mary, FL 32746 USA

Ship to

The Preserve at Wilderness Lake CDD
21320 Wilderness Lake Blvd
Land O' Lakes, FL 34637 USA

Invoice details

Invoice no.: 34075
Terms: Net 45
Invoice date: 05/05/2026
Due date: 06/19/2026

#	Date	Product or service	Description	Qty	Rate	Amount
1.		Sales	PINE TREE REMOVAL FROM APPROVED PROPOSAL: 7532 Grasmere Drive. Scope of Work: *Flush cut and removal of a Pine tree at 7532 Grasmere Drive. *Includes all labor, hauling, and dumping fees.	1	\$400.00	\$400.00
					Total	\$400.00

INVOICE

RedTree Landscape Systems
5532 Auld Lane
Holiday, FL 34690

service@redtreelandscape.systems
+1 (888) 733-8799
redtreelandscapesystems.com



Bill to

The Preserve at Wilderness Lake CDD
250 International Parkway
Suite 208
Lake Mary, FL 32746 USA

Ship to

The Preserve at Wilderness Lake CDD
21320 Wilderness Lake Blvd
Land O' Lakes, FL 34637 USA

Invoice details

Invoice no.: 34074
Terms: Net 45
Invoice date: 05/05/2026
Due date: 06/19/2026

#	Date	Product or service	Description	Qty	Rate	Amount
1.		Sales	PINE TREE REMOVAL FROM APPROVED PROPOSAL: Adjacent to 7138 Kendall Heath Way. Scope of work: *Flush cut and removal of a Pine tree adjacent to 7138 Kendall Heath Way. *Includes all labor, hauling, and dumping fees.	1	\$400.00	\$400.00
					Total	\$400.00



DCSI, Inc. "Security & Sound"
 P.O. Box 265
 Lutz, FL 33548 USA
 813-949-6500
 info@dcsisecurity.com
 http://DCSIsecurity.com

Invoice

BILL TO
Wilderness Lake Lodge 250 International Parkway Suite 208 Lake Mary, FL 32746

SHIP TO
Wilderness Lake Lodge 21320 Wilderness Lake Boulevard Land O' Lakes, Florida 34637

INVOICE #	DATE	TOTAL DUE	DUE DATE	TERMS	ENCLOSED
35092	04/23/2026	\$494.00	05/08/2026	Net 15	

P.O. NUMBER
11319

SALES REP
Tech: DC

DATE	ACTIVITY	QTY	RATE	AMOUNT
04/07/2026	Camera/DVR Service (C) Reason for call: 1. Install new HDD in Hikvision XVR. 2. Check back PTZ – looking at ground after power outage. 3. Front PTZ not on the network – please check. Tech Notes: 1. Installed and formatted new HDD in the Hikvision XVR. 2. Checked the back entrance PTZ and reprogrammed the home position. OK. 3. Reinitialized the front PTZ and reconnected it to the network. OK.	1	145.00	145.00
04/07/2026	Camera/DVR Parts ST8000VE201 SkyHawk AI 8TB Surveillance Hard Drive	1	349.00	349.00

Thank you for choosing DCSI, Inc as your "Security & Sound" company!
 *ALL SYSTEMS COME WITH 90 DAYS WARRANTY ON LABOR AND ONE YEAR WARRANTY ON PARTS, UNLESS OTHERWISE NOTED.
 **Returned Checks will receive \$25 NSF Fee.
 ***Late Fees are 1.5% per month

SUBTOTAL	494.00
TAX (0.075)	0.00
TOTAL	494.00
BALANCE DUE	\$494.00



Invoice

SUNRISE PROPANE
10105 HUDSON AVE
HUDSON, FL 34669
(727)862-2948

Customer ID: PRESER
Location: 1
Account No: 8043
WILDERNESS LAKE PRESERVE
21320 WILDERNESS LAKE BLVD,
LAND O' LAKES, FL 34639

Invoice # : 11114220
Date : 5/1/2025
Time : 8:44 AM
Totalizer : 2097990.5 - 2098228.8
Driver : 21
Truck : 3318
Begin % : 173
Ending % : 85

28-2886178 -02 4638860

QTY	Description	Amount
1000.00	Propane	\$679.16

Capacity	Equip ID
1000.00	858029
1000.00	858031

Taxes \$0

Total Due \$679.16

Full Payment Due on 5/11/2025



10-S Tennis Supply & Dinkshot Pickleball
 1400 NW 13th Avenue
 Pompano Beach, FL 33069
 Toll-Free: (800) 247-3907
 Local: (954) 969-5440
 www.10-S.com / www.dinkshot.com

Invoice

#175392

Date: 5/6/2026

Bill To

Tish Dobson
 Vesta Property Services
 250 International Pkwy, Suite 208
 Lake Mary FL 32746
 United States

Ship To

The Preserve at Wilderness Lake
 21320 Wilderness Lake Blvd
 Land O'Lakes FL 34637
 United States

Terms	Due Date	PO #	Sales Rep	Ship Via
Due on receipt CC or Check	5/16/2026	Tish Dobson	Kimberly Valencia	FedEx Ground®

Quantity	Item	Options	Customer Description	Rate	Amount
1	KW1006 Wilson US Open Hard Court Extra Duty Balls - Case of 72 balls			\$128.00	\$128.00

Subtotal	\$128.00
Shipping Costs (FedEx Ground®)	\$23.89
Tax (0%)	\$0.00
Total	\$151.89
Amount Paid	\$0.00
Amount Due	\$151.89



175392

Brletic Dvorak Inc

536 4th Ave South Unit 4
Saint Petersburg, FL 33701 US
(813) 361-1466
sbrletic@bdiengineers.com



INVOICE

BILL TO

Preserve at Wilderness Lake CDD
Vesta Property Services
250 International Pkwy., Ste. 208
Lake Mary, Florida 32746
United States

INVOICE 2411
DATE 05/01/2026
TERMS Net 30
DUE DATE 05/31/2026

PROJECT NAME

Preserve at Wilderness Lake CDD

	DESCRIPTION	QTY	RATE	AMOUNT
Project Manager	[April 03 - April 30]	4:30	210.00	945.00

BALANCE DUE **\$945.00**

Pay invoice



Preserve at Wilderness Lake COMMUNITY DEVELOPMENT DISTRICT
Apr-26

	<u>HOURS</u>	<u>RATE</u>	<u>PERSON</u>	<u>TOTAL</u>
<u>CDD Activities</u>				
Board Meeting Prep, Attendance, Follow up Engineer's Reports/Invoicing	1.50	\$210	S. Brletic	\$315.00
Records Request per DM	0.50	\$210	S. Brletic	\$105.00
Shade Structure Review, Site Visit, Correspondence	2.50	\$210	S. Brletic	\$525.00
INVOICE TOTAL	4.50			\$945.00



250 International Parkway, Suite 208

Lake Mary, FL 32746

TEL: 321-263-0132

Invoice

Bill To

The Preserve @ Wilderness Lake Community Developm...
c/o Vesta District Services
250 International Parkway
Suite 208
Lake Mary FL 32746

Date 05/01/2026

Invoice # 432480

In Reference To:

Monthly contracted management fees, as follows:

**PLEASE REMIT PAYMENT TO CORPORATE HEADQUARTERS:
VESTA DISTRICT SERVICES
c/o Vesta Property Services, Inc.
245 Riverside Avenue, Suite 300
Jacksonville, FL 32202**

Description	Quantity	Rate	Amount
District Management Services	1	3,181.67	3,181.67
Government & Trust Fund Accounting Services	1	2,232.00	2,232.00
General Administration Services	1	762.17	762.17
Assessment Preparation	1	491.33	491.33
Financial & Revenue Collections	1	491.33	491.33

Total 7,158.50



10-S Tennis Supply & Dinkshot Pickleball
 1400 NW 13th Avenue
 Pompano Beach, FL 33069
 Toll-Free: (800) 247-3907
 Local: (954) 969-5440
 www.10-S.com / www.dinkshot.com

Invoice

#175471

Date: 5/8/2026

Bill To

Tish Dobson
 Vesta Property Services
 250 International Pkwy, Suite 208
 Lake Mary FL 32746
 United States

Ship To

The Preserve at Wilderness Lake
 21320 Wilderness Lake Blvd
 Land O'Lakes FL 34637
 United States

Terms	Due Date	PO #	Sales Rep	Ship Via
Net 30	6/7/2026	Tish Dobson	Kimberly Valencia	FedEx Ground®

Quantity	Item	Options	Customer Description	Rate	Amount
1	FN2008-G (Bag of 100) Aluminum Fence Tys 8 1/4"	Color: Green		\$45.00	\$45.00

Subtotal	\$45.00
Shipping Costs (FedEx Ground®)	\$23.89
Tax (0%)	\$0.00
Total	\$68.89
Amount Paid	\$0.00
Amount Due	\$68.89



175471

INVOICE

RedTree Landscape Systems

5532 Auld Lane
Holiday, FL 34690

service@redtreelandscape,systems
+1 (888) 733-8799
redtreelandscapesystems.com



Bill to

The Preserve at Wilderness Lake CDD
250 International Parkway
Suite 208
Lake Mary, FL 32746 USA

Ship to

The Preserve at Wilderness Lake CDD
21320 Wilderness Lake Blvd
Land O' Lakes, FL 34637 USA

Invoice details

Invoice no.: 34138
Terms: Net 45
Invoice date: 05/11/2026
Due date: 06/25/2026

#	Date	Product or service	Description	Qty	Rate	Amount
1.		Arbor Care	PINE TREES REMOVAL - 7919 CITRUS BLOSSOM DRIVE: Scope of Work: *Flush cut and removal of two pine trees at 7919 Citrus Blossom Dr.	1	\$800.00	\$800.00
					Total	\$800.00



ORDER CONFIRMATION - INVOICE

Pricing and Availability Notice

Due to ongoing supply chain challenges, some hardware manufacturers cannot guarantee product availability or pricing until the product is shipped. While we make every effort to honor quoted pricing, if a hardware manufacturer increases its price to CDW after a quote is issued or order is accepted, we may need to update your quoted price to reflect that change irrespective of any timeframes or validity periods set forth in the quote, including up to the date of shipment. In the event of a price adjustment, we will notify you prior to shipment. Any price adjustment would only occur if the hardware manufacturer increases its pricing to CDW.

TISH DOBSON,

Thank you for choosing CDW•G. We have received your online order. Please take a moment to review it for accuracy and completeness.

[View Order Online](#)

ORDER #	ORDER DATE	PO #	CUSTOMER #
PVZL231	4/17/2026	4-17-26	11641324

ORDER DETAILS

ITEM	QTY	CDW#	UNIT PRICE	EXT. PRICE
SonicWall Advanced Protection Service Suite - subscription license (3 years)	1	6337148	\$1,621.59	\$1,621.59
Mfg. Part#: 02-SSC-6531				
Electronic distribution - NO MEDIA				
Contract: MARKET				

SUBTOTAL	\$1,621.59
SHIPPING	\$0.00
SALES TAX	\$0.00
GRAND TOTAL	\$1,621.59

PURCHASER BILLING INFO	DELIVER TO
Billing Address: THE PRESERVE AT WILDERNESS LAKE CDC 21320 WILDERNESS LAKE BLVD LAND O LAKES, FL 34637-7879 Phone: (813) 995-2437 Payment Terms: Net 30 Days-Govt State/Local	Shipping Address: THE PRESERVE AT WILDERNESS LAKE CDC 21320 WILDERNESS LAKE BLVD LAND O LAKES, FL 34637-7879 Phone: (813) 995-2437 Shipping Method: ELECTRONIC DISTRIBUTION
	Please remit payments to: CDW Government 75 Remittance Drive Suite 1515 Chicago, IL 60675-1515



Sales Contact Info

Sccg House Account | 800.808.4239 |

Need Help?



My Account



Support



Call 800.800.4239

[About Us](#) | [Privacy Policy](#) | [Terms and Conditions](#)

This order is subject to CDW's Terms and Conditions of Sales and Service Projects at
<http://www.cdw.com/content/terms-conditions/product-sales.aspx>

For more information, contact a CDW account manager

© 2026 CDW•G LLC, 200 N. Milwaukee Avenue, Vernon Hills, IL 60061 | 800.808.4239



4740B Allen Rd PMB
Zephyrhills, FL 33541

www.cooperpoolsinc.com

EIN 27-1602937
License # CPC1459240

Wilderness Lake Preserve
21320 Wilderness Lake Boulevard
Land O' Lakes FL 34637

PLEASE PAY BY	AMOUNT	INVOICE DATE
06/14/2026	\$1,536.32	05/15/2026

INVOICE NO. 761

Order No.:
Quote No.:
Job No.: 1149
Site Address: 21320 Wilderness Lake
Boulevard
Land O' Lakes FL 34637

Install Light at Resort Pool

Commercial Installation / Repairs

Item	Quantity	Unit Price	Total
60214 26W 12V 150' White Pool 300W EQ IntelliBrite ARC LED	1.00	\$1,356.32	\$1,356.32
Commercial installation / Labor			\$180.00
Sub-Total ex Tax			\$1,536.32
Tax			\$0.00
Total			\$1,536.32

Sub-Total ex Tax	\$1,536.32
Tax	\$0.00
Total inc Tax	\$1,536.32
Amount Applied	\$0.00
Balance Due	\$1,536.32

How To Pay

INVOICE NO. 761



Credit Card (MasterCard or Visa)

Pay Online cooperpoolsinc.simprosuite.com/payment/
Please call 844-766-5256 to pay over the phone.



Direct Deposit

Bank **PNC Bank**
Acc. Name **6768**
Routing Number **267084199**
Acc. No. **1241206768**

DUE DATE:	06/14/2026	AMOUNT DUE:	\$1,536.32
------------------	-------------------	--------------------	-------------------

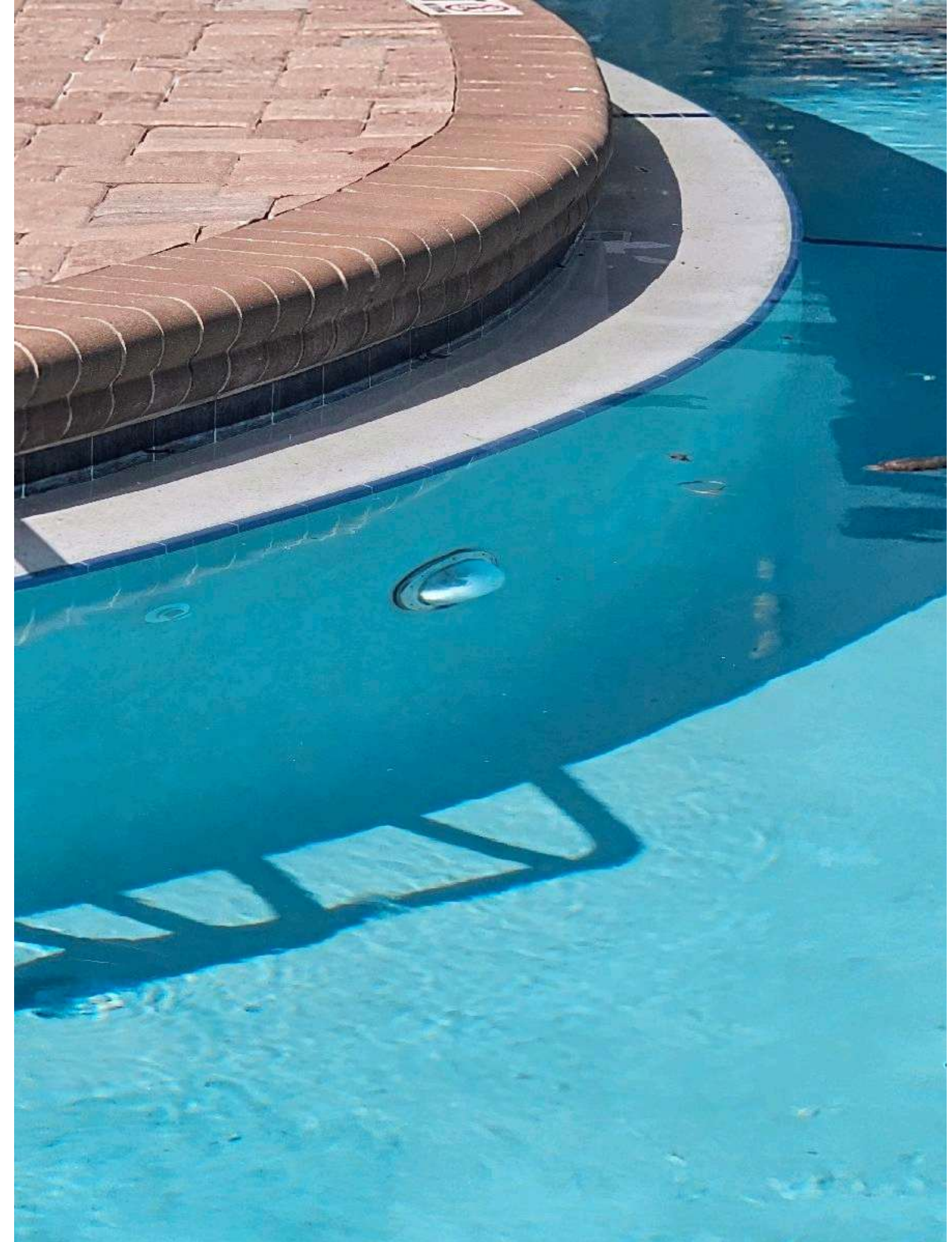



4740B Allen Rd PMB
Zephyrhills, FL 33541

www.cooperpoolsinc.com

EIN 27-1602937
License # CPC1459240

Wilderness Lake Preserve
21320 Wilderness Lake Boulevard
Land O' Lakes FL 34637

PLEASE PAY BY	AMOUNT	INVOICE DATE
06/14/2026	\$7,861.60	05/15/2026

INVOICE NO. 760

Order No.:
Quote No.:
Job No.: 1356
Site Address: 21320 Wilderness Lake
Boulevard
Land O' Lakes FL 34637

Remove & Install 5 White Pool Lights

Commercial Installation / Repairs

Item	Quantity	Unit Price	Total
150' Pentair IB Pool Light White 300W 12V	5.00	\$1,356.32	\$6,781.60
Commercial installation / Labor			\$1,080.00
Sub-Total ex Tax			\$7,861.60
Tax			\$0.00
Total			\$7,861.60

Sub-Total ex Tax	\$7,861.60
Tax	\$0.00
Total inc Tax	\$7,861.60
Amount Applied	\$0.00
Balance Due	\$7,861.60

How To Pay

INVOICE NO. 760

Credit Card (MasterCard or Visa)
Pay Online cooperpoolsinc.simprosuite.com/payment/
Please call 844-766-5256 to pay over the phone.

Direct Deposit
Bank **PNC Bank**
Acc. Name **6768**
Routing Number **267084199**
Acc. No. **1241206768**

DUE DATE:	06/14/2026	AMOUNT DUE:	\$7,861.60
------------------	-------------------	--------------------	-------------------

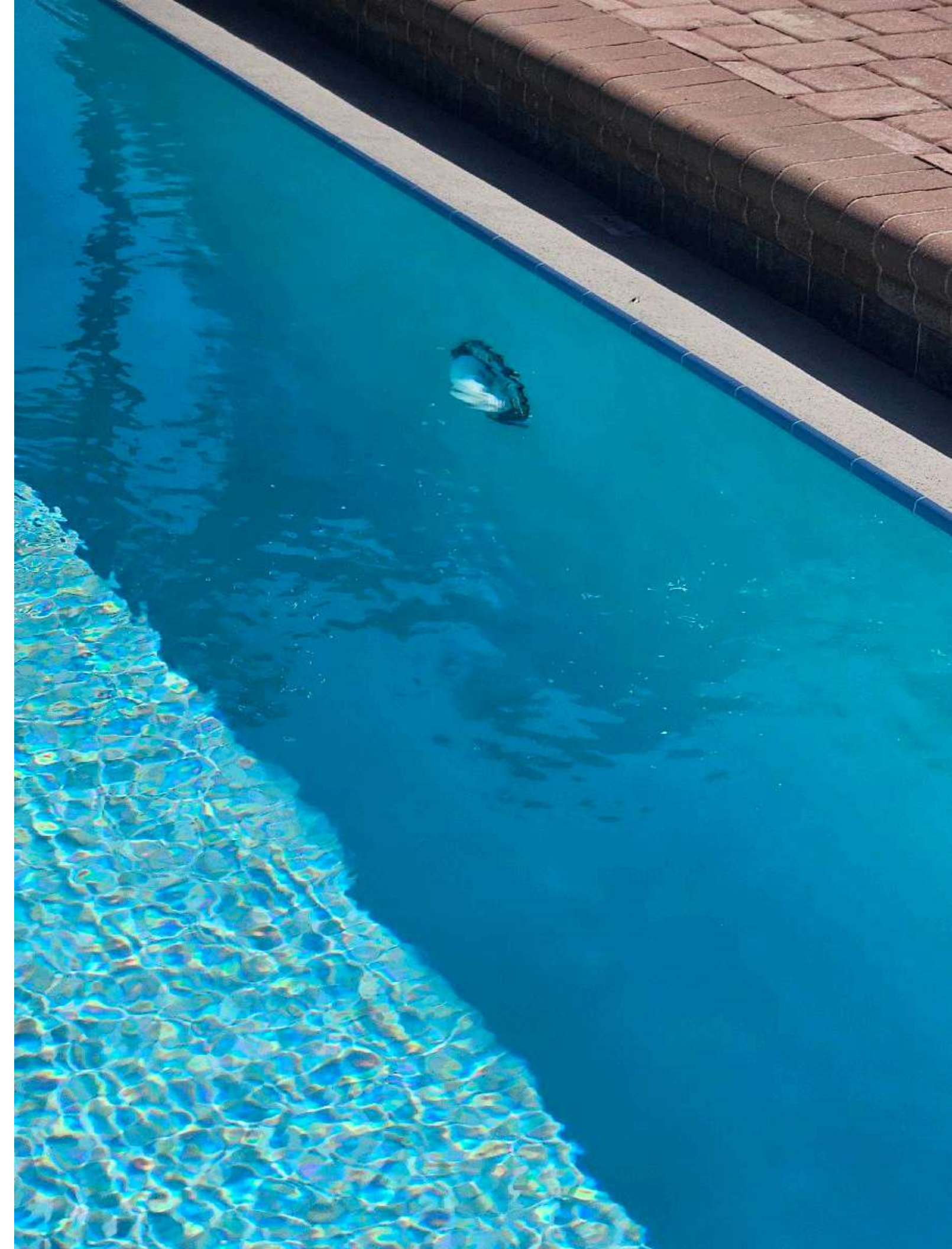

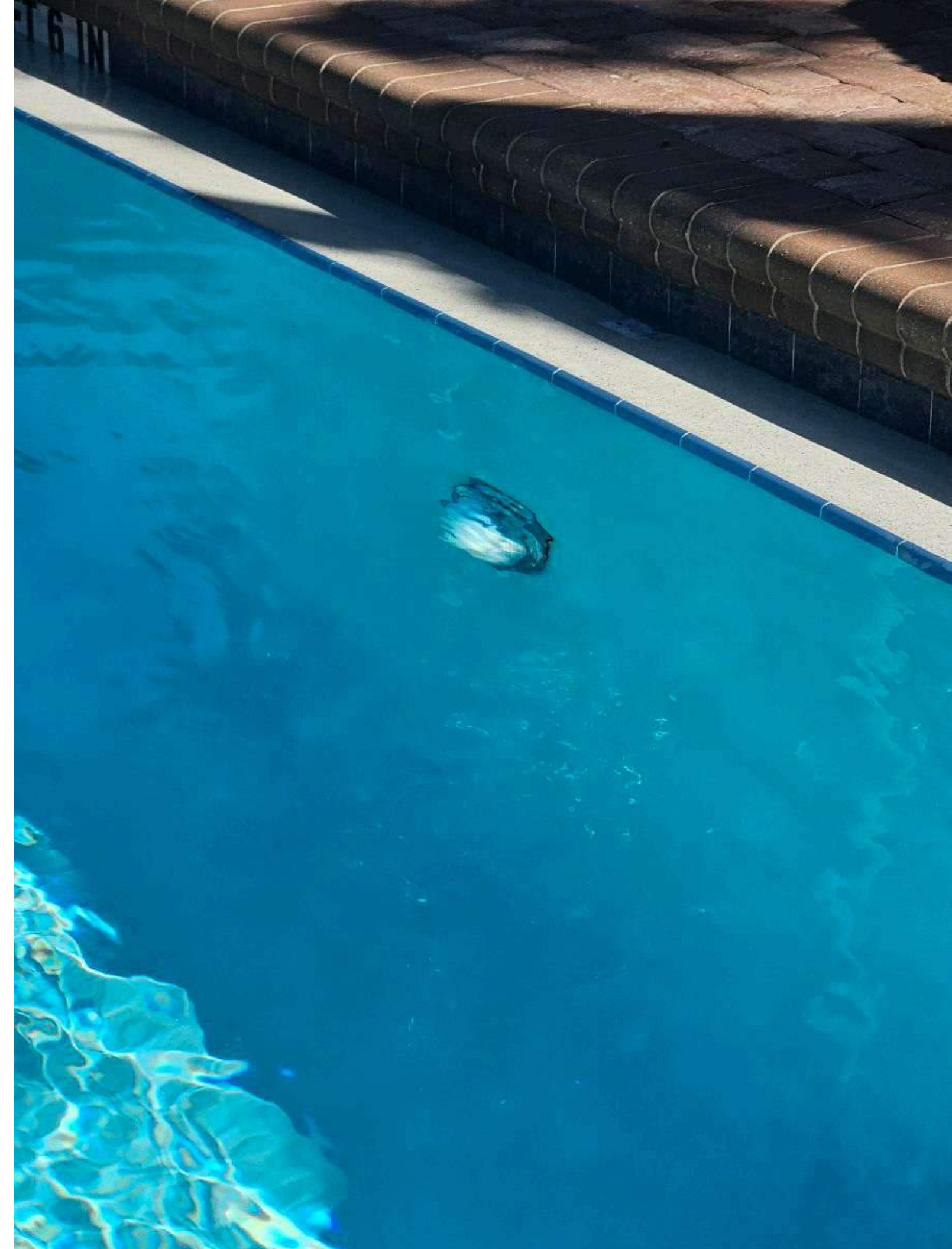

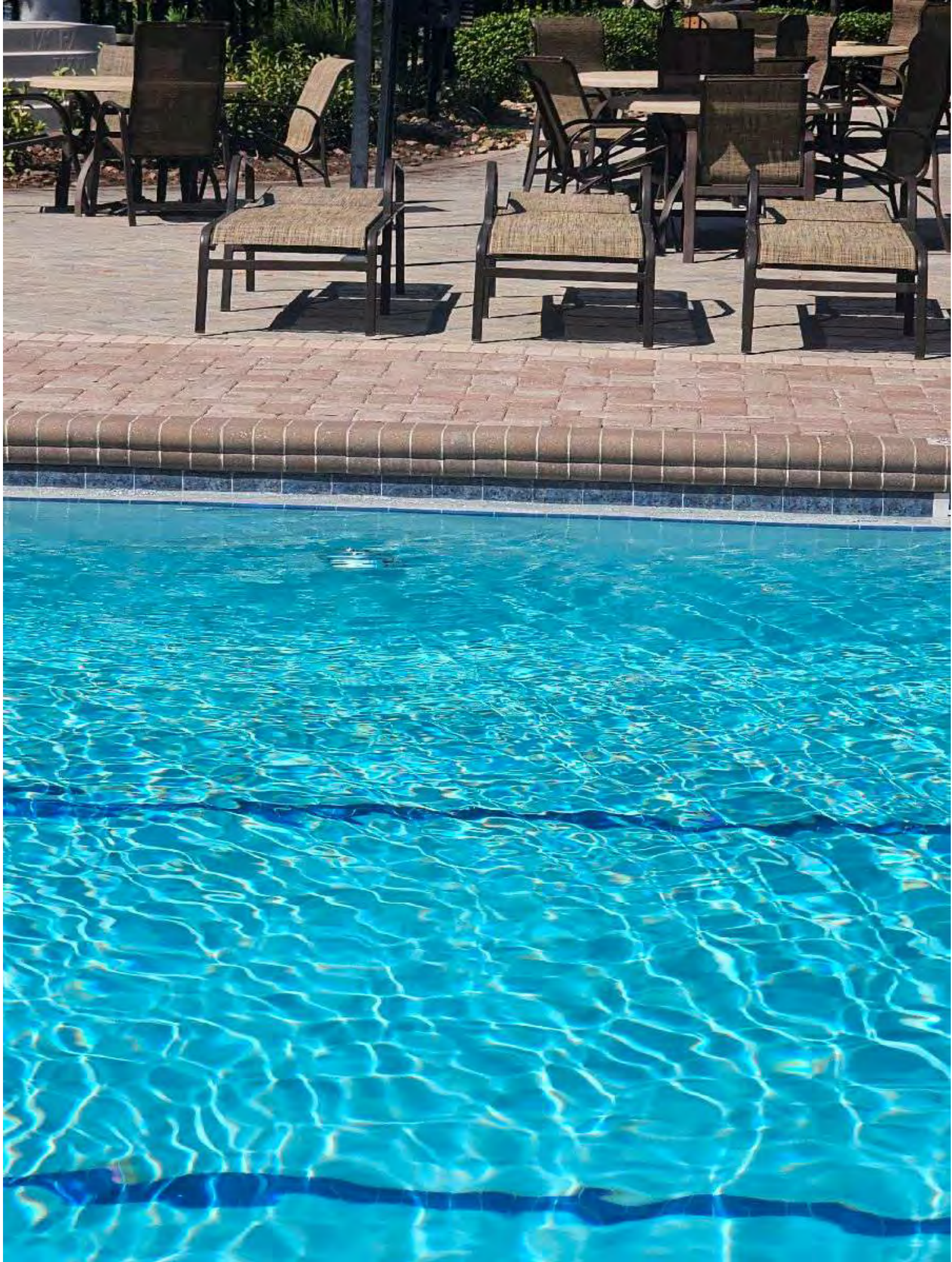

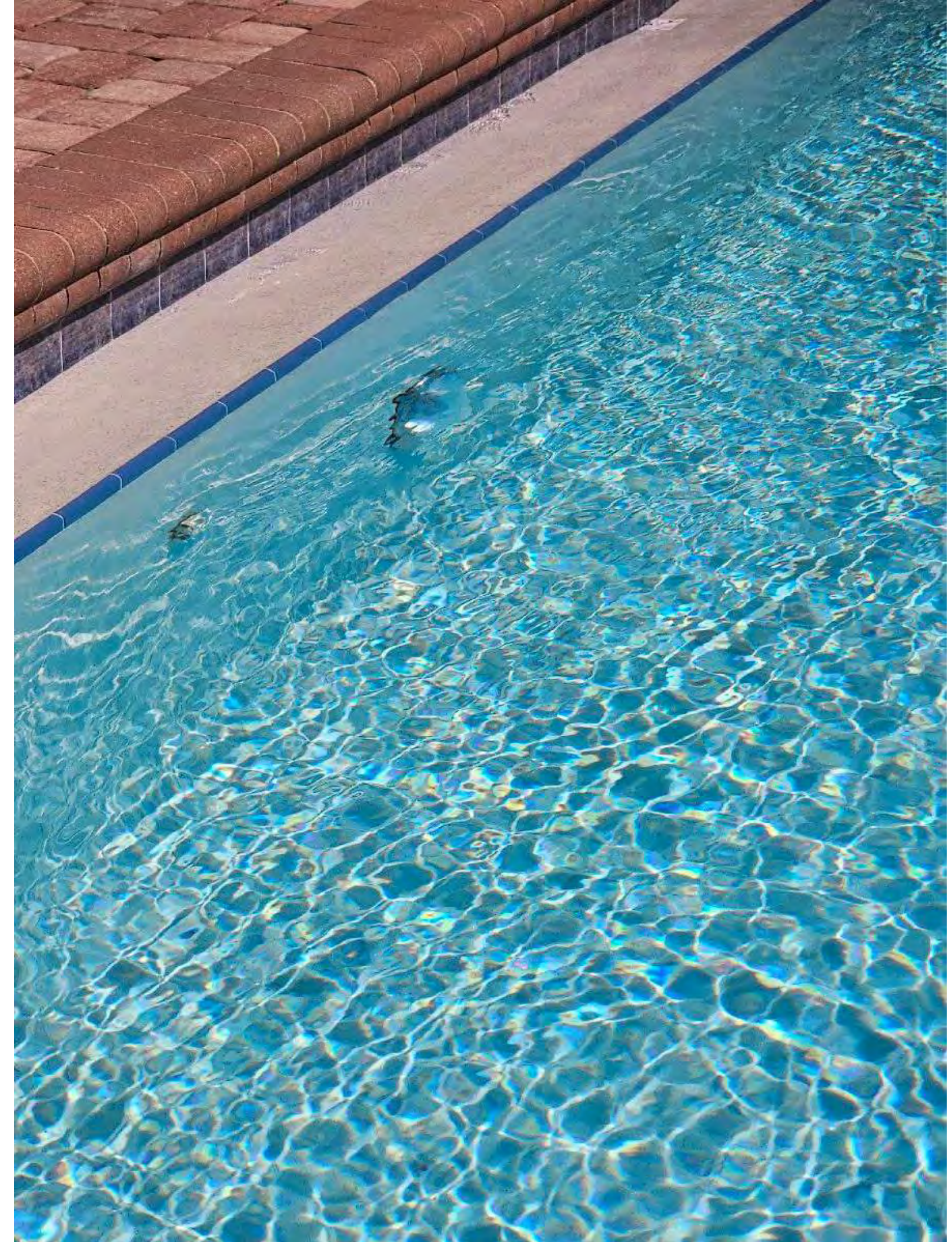

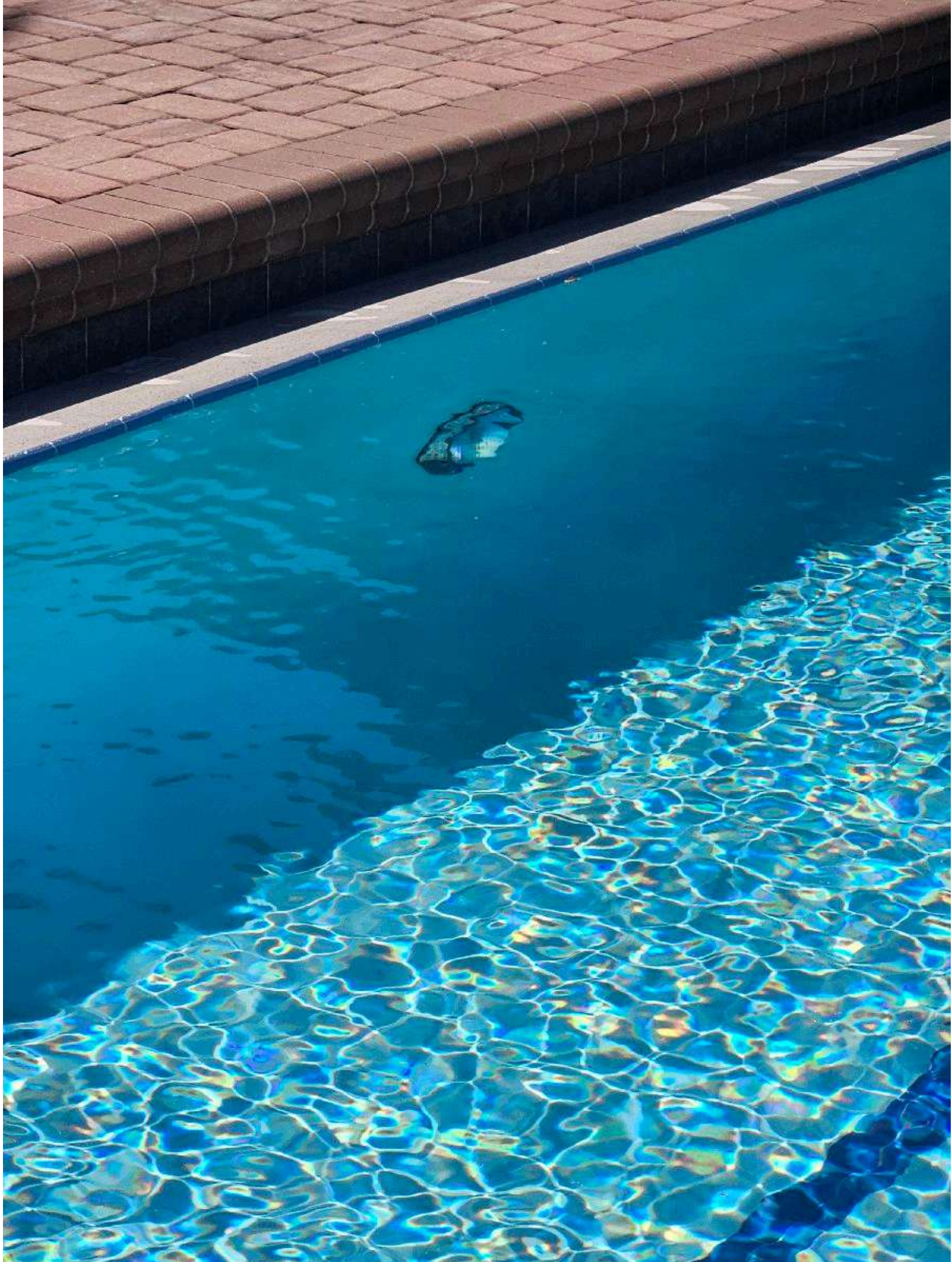



Fitness Logic

380 Scarlet Blvd

Phone #
727-784-4964

Fax #
727-784-0223

E-mail
fitlogic@aol.com

Invoice

Date	Invoice #
5/14/2026	129836

Bill To
Preserve at Wilderness Lake 21320 Wilderness Lake Boulevard Land O' Lakes, FL 34637

Location/Contact/Phone
Preserve at Wilderness Lake 21320 Wilderness Lake Boulevard Land O' Lakes, FL 34637 813-995-2437

P.O. Number	Terms	Rep	Work Order #	Completed
	Net 10	JRZ	19817	5/13/2026

Item Code	Description	Quantity	Price Each	Amount
Parts	Pedal wheels	2	99.99	199.98
Shipping	Shipping charges are estimated and subject to change. Standard Shipping: 7-10 business days	1	26.00	26.00
Labor	Replace (2) Pedal wheels on Precor Elliptical. Serial # A485L27220024 Model # A459L20225215	1	125.00	125.00

Thank you for your business. Invoices over 30 Days will incur 1.5% Interest per month	Subtotal	\$350.98
	Sales Tax (0.0%)	\$0.00
	Total	\$350.98



www.ghsenvironmental.com
 P.O. Box 55802
 St Petersburg, FL 33732

Invoice

Date: 5/13/2026
 Invoice #: 2026-362

To:

The Preserve at Wilderness Lake CDD
 5844 Old Pasco, Suite 100
 Wesley Chapel, FL 33544

Project: WLP Services

Proposal #: 25-227

P.O. #:

Due Date	Service Date:
6/12/2026	April 2026

Task #	Description	Project Compl...	Amount
Task 1	Monthly Aquatic Weed Control Program	58.33%	2,875.00
Task 2	Communication and Field Reviews with WLP Staff / CDD	58.34%	166.67
Task 3	Private Resident Consultation	58.33%	65.00
Task 4	Wetland Nuisance/Exotic Species Reduction	58.33%	875.00
Task 6	Routine Wetland Buffer Maintenance	39.67%	2,200.00

PAYMENT DUE WITHIN 30 DAYS OF INVOICING DATE	Total	\$6,181.67
<p>Please make all checks payable to GHS Environmental There will be a 10% charge per month on any payments received after the initial 30 days. If you have any questions concerning this invoice please contact us at 727-667-6786. THANK YOU FOR YOUR BUSINESS!</p>	Payments/Credits	\$0.00
	Balance Due	\$6,181.67

Straley Robin Vericker

1510 W. Cleveland Street

Tampa, FL 33606

Telephone (813) 223-9400

Federal Tax Id. - 20-1778458

The Preserve at Wilderness Lake CDD
c/o Vesta District Services
250 International Pkwy, Ste. 208
Lake Mary, FL 32746

May 12, 2026

Client: 001029

Matter: 000001

Invoice #: 28327

Page: 1

RE: General Matters

For Professional Services Rendered Through April 30, 2026

SERVICES

Date	Person	Description of Services	Hours	Amount
4/8/2026	CAW	REVIEW AGENDA AND PREPARE FOR APRIL BOARD MEETING; EMAIL CORRESPONDENCE WITH DISTRICT MANAGER REGARDING MEETING.	0.4	\$122.00
4/10/2026	CAW	PREPARE FOR AND ATTEND APRIL BOARD MEETING VIA PHONE.	1.5	\$457.50
4/14/2026	CAW	REVIEW AND DISTRIBUTE LETTER FROM RESIDENT AT 7405 NIGHT HERON DRIVE; EMAIL CORRESPONDENCE WITH DISTRICT MANAGER REGARDING SAME.	0.3	\$91.50
4/22/2026	CAW	REVIEW RESOLUTION APPROVING PROPOSED 2026/2027 BUDGET AND SETTING A PUBLIC HEARING.	0.2	\$61.00
4/23/2026	AM	UPDATE PUBLICATION NOTICE FOR GENERAL ELECTION WITH DISTRICTS PREFERRED NEWSPAPER.	0.1	\$17.50
4/28/2026	CAW	REVIEW EMAIL CORRESPONDENCE REGARDING DISTRICT INCIDENT REPORTS.	0.2	\$61.00
Total Professional Services			2.7	\$810.50

May 12, 2026

Client: 001029

Matter: 000001

Invoice #: 28327

Page: 2

Total Services	\$810.50	
Total Disbursements	\$0.00	
Total Current Charges		\$810.50
Previous Balance		\$3,728.78
<i>Less Payments</i>		<i>(\$3,728.78)</i>
PAY THIS AMOUNT		\$810.50

Please Include Invoice Number on all Correspondence

INVOICE

Cool Coast Heating & Cooling,
Inc.
7050 15th St E #30
Sarasota, FL 34243

office@coolcoast.net
+9264710
coolcoast.net



The Preserve at Wilderness Lake CDD/21320

Bill to

The Preserve at Wilderness Lake CDD
21320 Wilderness Lake Blvd
Land O' Lakes, FL 34637

Ship to

The Preserve at Wilderness Lake CDD
21320 Wilderness Lake Blvd
Land O' Lakes, FL 34637

Invoice details

Technician: Elton

Invoice no.: 1351274
Terms: Net 30
Invoice date: 05/13/2026
Due date: 06/12/2026

#	Date	Product or service	Description	Qty	Rate	Amount
1.	05/13/2026	Service Call	CALL/DIAGNOSTICS -Rec room unit not cooling -Tech arrived and inspected unit -Found system 2 off due to float switch being tripped -Secondary drain pan full of water - clear pan and drain line blockage	1	\$289.00	\$289.00
2.	05/13/2026	Level 2	EXTENSIVE DRAIN LINE: -Had to blow line out w/ nitrogen to clear -Vacuum and backflushed drain line -Cleared excess water from secondary drain pan (Approx. 5gal) -Cleaned float switch and cleaned build up from around fob -Chemically treated drain line and pan -Tested system for proper drainage -System draining and running properly at this time	1	\$189.00	\$189.00
3.	05/13/2026	Fuel Surcharge	Fuel Surcharge	1	\$10.00	\$10.00
4.	05/13/2026	Processing Fee	*If paying w/ CC a %3.5 processing fee will be applied (not shown in totals) **Amex is %4.5	488	\$0.035	\$17.08

Total **\$505.08**

Ways to pay



Thank you for your business! We accept ACH transfers and checks.
To pay with a credit card, please contact our office at (941) 926-4710.

Note to customer

TERMS:

CASH/CHECK PRICE. 50% DEPOSIT. BALANCE DUE UPON COMPLETION. Add 3.5% for credit card processing.

- All work is to be completed in a timely and professional manner.
- Any alteration from above specifications will be addressed and agreed upon before alteration takes place as extra costs may incur.
- Pricing subject to change within 30 days. Payment due upon completion or as specified. Amount unpaid within terms are subject to a 1.5% monthly finance charge.
- Purchaser agrees to pay all costs of collections. 15% restocking fee for all returned/canceled parts and/or equipment.

**NOTE: Any returned payments will result in a minimum fee of \$40 and all bank fees associated with the returned payment.

[View and pay](#)

INVOICE

PSA Horticultural
8431 Prestwick Pl
Trinity, FL 34655

tom@psagrounds.com
+1 (727) 505-1532



Bill to

The Preserve at Wilderness Lake CDD c/o
Vesta Property Services
250 International Pkwy., Ste. 208
Lake Mary, FL 32746

Ship to

The Preserve at Wilderness Lake CDD c/o
Vesta Property Services
250 International Pkwy., Ste. 208
Lake Mary, FL 32746

Invoice details

Invoice no.: 1694
Terms: Net 30
Invoice date: 05/14/2026
Due date: 06/13/2026

#	Date	Product or service	Description	Qty	Rate	Amount
1.	05/14/2026	Preserve at Wilderness Lake CDD monthly landscape inspection	May 2026 Landscape Inspection	1	\$1,100.00	\$1,100.00

Total **\$1,100.00**

Ways to pay



Note to customer

We truly appreciate your business!

PSA Services:
Specification Development
Landscape Inspections
Special Project Consulting

[View and pay](#)

INVOICE

RedTree Landscape Systems
5532 Auld Lane
Holiday, FL 34690

service@redtreelandscape,systems
+1 (888) 733-8799
redtreelandscapesystems.com



Bill to

The Preserve at Wilderness Lake CDD
250 International Parkway
Suite 208
Lake Mary, FL 32746 USA

Ship to

The Preserve at Wilderness Lake CDD
21320 Wilderness Lake Blvd
Land O' Lakes, FL 34637 USA

Invoice details

Invoice no.: 34158
Terms: Net 45
Invoice date: 05/12/2026
Due date: 06/26/2026

#	Date	Product or service	Description	Qty	Rate	Amount
1.			Irrigation repairs were performed as follows on 4.15.26 Lodge Timer: Repairs to zone 11.			
2.		Sales	maxi jet	7	\$3.14	\$21.98
3.		Sales	drip pipe	6	\$1.00	\$6.00
4.		Sales	drip tee	1	\$1.00	\$1.00
5.		Sales	labor-technician	4	\$65.00	\$260.00
					Total	\$288.98

INVOICE

RedTree Landscape Systems

5532 Auld Lane
Holiday, FL 34690

service@redtreelandscape,systems

+1 (888) 733-8799

redtreelandscapesystems.com



Bill to

The Preserve at Wilderness Lake CDD
250 International Parkway
Suite 208
Lake Mary, FL 32746 USA

Ship to

The Preserve at Wilderness Lake CDD
21320 Wilderness Lake Blvd
Land O' Lakes, FL 34637 USA

Invoice details

Invoice no.: 34157

Terms: Net 45

Invoice date: 05/12/2026

Due date: 06/26/2026

#	Date	Product or service	Description	Qty	Rate	Amount
1.			Irrigation repairs were performed as follows on 4.15.26 Neighborhood Park Timer: Replaced broken solenoids and rotor on zones 3 & 4.			
2.		Sales	4" rotor	1	\$25.00	\$25.00
3.		Sales	solenoid	2	\$60.00	\$120.00
4.		Sales	labor-technician	1	\$65.00	\$65.00
					Total	\$210.00

INVOICE

Inteligy Tampa Bay LLC
3501 Bessie Coleman Blvd Unit
23702
Tampa, FL 33623-9030

jennifer.picciurro@inteligy.com
+1 (813) 769-4695
www.inteligy.com



Bill to

Tish Dobson
The Preserve at Wilderness Lake CDD
21320 Wilderness Lake Blvd.
Land O' Lakes, FL 34637

Invoice details

Invoice no.: 24743
Terms: Due on receipt
Invoice date: 05/15/2026

#	Product or service	Description	Qty	Rate	Amount
1.	Flat Rate Hosted Service	Flat Rate Hosted Services	1	\$300.00	\$300.00
2.	T-38 Faxing	T-38 Faxing Service	1	\$30.00	\$30.00
				Total	\$330.00

Ways to pay



View and pay



A Total Solution, Inc.
3487 Keystone Road
Tarpon Springs, FL 34688

Phone: (727) 942-1993
www.atotalsolution.com

Bill to
Wilderness Lake Preserve
C/o Vesta District Services
250 International Pkwy., Ste208
Lake Mary, FL 32746

Ship to
Wilderness Lake Preserve
Wilderness Lake Preserve
21320 Wilderness Lake Blvd
Land O Lakes, FL 33543

Work Order Description
Semi Annual Fire Sprinkler Inspection

Work Summary
Semi-annual Fire Sprinkler Inspection completed. No deficiencies found.

Work Order #: 12791 Transaction Date: 5/7/2026 Invoice Due Date: 6/1/2026

Invoice #: i10178

Task: Semi-Annual Wet System Insp

Description	Quantity
Compliance Engine Upload Fee	1
Semi-Annual Inspection of Fire Sprinkler System and a copy of the inspection report to be secured in the facility's fire alarm log book.	1

Subtotal: \$37.00

Tax: \$0.00

Total: \$37.00

Payments: \$0.00

Balance Due: \$37.00

E-mail: accountsreceivable@atotalsolution.com



A Total Solution, Inc.
3487 Keystone Road
Tarpon Springs, FL 34688

Phone: (727) 942-1993
www.atotalsolution.com

Bill to
Wilderness Lake Preserve
C/o Vesta District Services
250 International Pkwy., Ste208
Lake Mary, FL 32746

Ship to
Wilderness Lake Preserve
Wilderness Lake Preserve
21320 Wilderness Lake Blvd
Land O Lakes, FL 33543

Work Order Description
Semi Fire Alarm Inspection

Work Summary
Semi-annual Fire Alarm Inspection completed. No deficiencies noted.

Work Order #: 12820 Transaction Date: 5/7/2026 Invoice Due Date: 6/1/2026

Invoice #: i10205

Task: Semi-Annual Fire System & Devices

Description	Quantity
Semi-Annual inspection of Fire Alarm System and a copy of the inspection report to be secured in the facility's fire alarm log book.	1
Compliance Engine Upload Fee	1

Subtotal: \$37.00

Tax: \$0.00

Total: \$37.00

Payments: \$0.00

Balance Due: \$37.00

E-mail: accountsreceivable@atotalsolution.com

INVOICE

RedTree Landscape Systems

5532 Auld Lane
Holiday, FL 34690

service@redtreelandscape,systems

+1 (888) 733-8799

redtreelandscapesystems.com



Bill to

The Preserve at Wilderness Lake CDD
250 International Parkway
Suite 208
Lake Mary, FL 32746 USA

Ship to

The Preserve at Wilderness Lake CDD
21320 Wilderness Lake Blvd
Land O' Lakes, FL 34637 USA

Invoice details

Invoice no.: 34256

Terms: Net 45

Invoice date: 05/19/2026

Due date: 07/03/2026

#	Date	Product or service	Description	Qty	Rate	Amount
1.		Sales	FLUSH CUT AND INSTALLATION FROM APPROVED PROPOSAL: Scope of Work: *Flush cut a declining Ligustrum tree. *Installation of (1) 30-gallon Bracken Browns Magnolia tree on the other side of the fence. *Installation of (3) 3-gallon Pink Muhly Grass in the area bed.	1	\$984.00	\$984.00
					Total	\$984.00

INVOICE

RedTree Landscape Systems
5532 Auld Lane
Holiday, FL 34690

service@redtreelandscape,systems
+1 (888) 733-8799
redtreelandscapesystems.com



Bill to

The Preserve at Wilderness Lake CDD
250 International Parkway
Suite 208
Lake Mary, FL 32746 USA

Ship to

The Preserve at Wilderness Lake CDD
21320 Wilderness Lake Blvd
Land O' Lakes, FL 34637 USA

Invoice details

Invoice no.: 34255
Terms: Net 45
Invoice date: 05/19/2026
Due date: 07/03/2026

#	Date	Product or service	Description	Qty	Rate	Amount
1.		Sales	PLAYGROUND MULCH INSTALLATION FROM APPROVED PROPOSAL: Scope of Work: *Install (85) cubic yards of certified playground mulch.	1	\$7,225.00	\$7,225.00
					Total	\$7,225.00

INVOICE

RedTree Landscape Systems

5532 Auld Lane
Holiday, FL 34690

service@redtreelandscape,systems
+1 (888) 733-8799
redtreelandscapesystems.com



Bill to

The Preserve at Wilderness Lake CDD
250 International Parkway
Suite 208
Lake Mary, FL 32746 USA

Ship to

The Preserve at Wilderness Lake CDD
21320 Wilderness Lake Blvd
Land O' Lakes, FL 34637 USA

Invoice details

Invoice no.: 34257
Terms: Net 45
Invoice date: 05/19/2026
Due date: 07/03/2026

#	Date	Product or service	Description	Qty	Rate	Amount
1.		Sales	VIBURNUM ODORATISSIMUM INSTALLATION FROM APPROVED PROPOSAL: Scope of Work: *Removal of the existing Pineapple Guava hedge. *Installation of (12) 3-gallon Viburnum Odoratissimum.	1	\$390.00	\$390.00
					Total	\$390.00

INVOICE

RedTree Landscape Systems
5532 Auld Lane
Holiday, FL 34690

service@redtreelandscape,systems
+1 (888) 733-8799
redtreelandscapesystems.com



Bill to

The Preserve at Wilderness Lake CDD
250 International Parkway
Suite 208
Lake Mary, FL 32746 USA

Ship to

The Preserve at Wilderness Lake CDD
21320 Wilderness Lake Blvd
Land O' Lakes, FL 34637 USA

Invoice details

Invoice no.: 34258
Terms: Net 45
Invoice date: 05/19/2026
Due date: 07/03/2026

#	Date	Product or service	Description	Qty	Rate	Amount
1.		Sales	VIBURNUM ODORATISSIMUM INSTALLATION FROM APPROVED PROPOSAL: Scope of Work: *Installation of (25) 3-gallon Viburnum Odoratissimum.	1	\$500.00	\$500.00
					Total	\$500.00

INVOICE

RedTree Landscape Systems
5532 Auld Lane
Holiday, FL 34690

service@redtreelandscape,systems
+1 (888) 733-8799
redtreelandscapesystems.com



Bill to

The Preserve at Wilderness Lake CDD
250 International Parkway
Suite 208
Lake Mary, FL 32746 USA

Ship to

The Preserve at Wilderness Lake CDD
21320 Wilderness Lake Blvd
Land O' Lakes, FL 34637 USA

Invoice details

Invoice no.: 34259
Terms: Net 45
Invoice date: 05/19/2026
Due date: 07/03/2026

#	Date	Product or service	Description	Qty	Rate	Amount
1.		Sales	FOXTAIL PALM INSTALLATION FROM APPROVED PROPOSAL: Scope of Work: *Installation of (1) 30-gallon triple trunk Foxtail Palm tree, between the rocks.	1	\$545.00	\$545.00
					Total	\$545.00

INVOICE

RedTree Landscape Systems

5532 Auld Lane
Holiday, FL 34690

service@redtreelandscape,systems
+1 (888) 733-8799
redtreelandscapesystems.com



Bill to

The Preserve at Wilderness Lake CDD
250 International Parkway
Suite 208
Lake Mary, FL 32746 USA

Ship to

The Preserve at Wilderness Lake CDD
21320 Wilderness Lake Blvd
Land O' Lakes, FL 34637 USA

Invoice details

Invoice no.: 34260
Terms: Net 45
Invoice date: 05/19/2026
Due date: 07/03/2026

#	Date	Product or service	Description	Qty	Rate	Amount
1.		Sales	LOROPETALUM INSTALLATION FROM APPROVED PROPOSAL - 7117 TIMBER RIDGE WAY: Scope of Work: *Removal of dead plant material. *Install (5) 3-gallon Loropetalum.	1	\$100.00	\$100.00
					Total	\$100.00

State Wildlife Trapper
2103 W Rio Vista Ave
Tampa, FL 33603 US
trapperjerry@gmail.com



INVOICE

BILL TO

Preserve at Wilderness Lakes
CDD
C/O Vesta District Services
250 International Pkwy.
Suite 208
Lake Mary, Florida 32746

INVOICE # 2149

DATE 05/18/2026

DUE DATE 06/02/2026

TERMS Net 15

ACTIVITY	QTY	RATE	AMOUNT
State Wildlife Service Service for May 2026	1	1,200.00	1,200.00

4 TRAPS/ 5 cameras are currently in use.

LTD: Hogs Removed: 223
29 piglets
YTD: Hogs Removed: 3
MTD: Hogs Removed: 1

Note:

We are doing everything possible to eliminate the hog population on this property.

Please make your check payable to Jerry Richardson, State Wildlife Trapper.
Thank you for doing business with us.

Make all checks payable to: Jerry Richardson

A late fee of 15% late fee will be applied if not paid within 10 days from date.

If you have any questions concerning this invoice, please contact: Jerry Richardson, Phone 813-390-9578; email - trapperjerry@gmail.com

A 30 day notice is required to terminate trapping service in writing.
Termination fees may apply.

SUBTOTAL	1,200.00
TAX	0.00
TOTAL	1,200.00
BALANCE DUE	\$1,200.00



INVOICE

INV-000193

Balance Due
\$2,100.00

Electro Sanitation Services

1750 Paladino Court
Odessa Florida 33556
U.S.A
electrosanitationservices@gmail.com

Wilderness Lake Preserve c/o Tish

23120 Wilderness Lake Blvd.
Land O Lakes
34637 Fl

Invoice Date : 17 May 2026

Terms : Due on Receipt

Due Date : 17 May 2026

#	Description	Qty	Rate	Amount
1	Weekly Cleaning @\$525/week 4/1-4/30	1.00	2,100.00	2,100.00
			Sub Total	2,100.00
			Total	\$2,100.00
			Balance Due	\$2,100.00

We appreciate your business!



INVOICE

INV-000194

Balance Due
\$399.81

Electro Sanitation Services

1750 Paladino Court
Odessa Florida 33556
U.S.A
electrosanitationservices@gmail.com

Wilderness Lake Preserve c/o Tish

23120 Wilderness Lake Blvd.
Land O Lakes
34637 Fl

Invoice Date : 17 May 2026

Terms : Due on Receipt

Due Date : 17 May 2026

#	Description	Qty	Rate	Amount
1	13 gallon White trash bags	1.00	23.95	23.95
2	Mini Jumbo Toilet Paper	1.00	49.99	49.99
3	Multi-fold Paper Towel	2.00	39.99	79.98
4	Tork Paper Towels	1.00	69.99	69.99
5	33g trash bags	1.00	26.99	26.99
6	Floor chemical	2.00	11.98	23.96
7	Gym Disinfectant Wipes	1.00	124.95	124.95
			Sub Total	399.81
			Total	\$399.81
			Balance Due	\$399.81

We appreciate your business!



4740B Allen Rd PMB
Zephyrhills, FL 33541

www.cooperpoolsinc.com

EIN 27-1602937
License # CPC1459240

Wilderness Lake Preserve
21320 Wilderness Lake Boulevard
Land O' Lakes FL 34637

PLEASE PAY BY	AMOUNT	INVOICE DATE
06/14/2026	\$420.00	05/15/2026

INVOICE NO. 768

Order No.: 938
Quote No.: 938
Job No.: 1381
Site Address: 21320 Wilderness Lake
 Boulevard
 Land O' Lakes FL 34637

AMP Draw was good, capacitor needs replaced

Commercial Installation / Repairs

Item	Quantity	Unit Price	Total
Replace Capacitor at Spa, AMP draw was good	1.00	\$420.00	\$420.00
Sub-Total ex Tax			\$420.00
Tax			\$0.00
Total			\$420.00

Sub-Total ex Tax	\$420.00
Tax	\$0.00
Total inc Tax	\$420.00
Amount Applied	\$0.00
Balance Due	\$420.00

How To Pay

INVOICE NO. 768



Credit Card (MasterCard or Visa)

Pay Online cooperpoolsinc.simprosuite.com/payment/
 Please call 844-766-5256 to pay over the phone.



Direct Deposit

Bank **PNC Bank**
 Acc. Name **6768**
 Routing Number **267084199**
 Acc. No. **1241206768**

DUE DATE:	06/14/2026	AMOUNT DUE:	\$420.00
------------------	-------------------	--------------------	-----------------

PRIMO BRANDS

Account Number: 000624023
 Invoice Number: 30000624023
 Activity From: 04/09/26 - 05/08/26
 Billing Date: 05/12/26
 Billing Address: THE PRESERVE AT WILDERNESS LAKE
 21320 WILDERNESS LAKE BLVD
 WILDERNESS LODGE
 LAND O LAKES FL 34537

Previous Balance	\$47.98
Payments / Credits	\$47.98
Current Activity from 04/09/26 - 05/08/26	\$47.98
<hr/>	
Total Account Balance as of 05/12/26	\$47.98

ReadyRefresh.com

News for You

Exciting new products and flavors have arrived! Explore Saratoga Collections Mango Dragon fruit, and Splash Refreshers new sparkling flavor, Acai Grape. Try our new Pure Life Baby water in 8oz bottles, perfect for formula and little ones. Add to your next order.

Date	Ticket #	Qty	Description	Unit Price	Amount
4/24	0537540		PREVIOUS BALANCE		47.98
			PAYMENT THANK YOU		-17.98
4/26	EC910542	1	ADMINISTRATIVE FEE RENT (04/26 05/25)		6.00
					17.98

Product, rental, and delivery prices are subject to change and may vary over time. Please refer to our terms and conditions for details. Thank you for being a valued customer!

Total Account Balance as of 05/12/26 \$47.98

Details based on invoice and other relevant information

Page 1 of 1

PO Box 30063
 College Station TX 77842

ACCOUNT NUMBER - 000624023 INVOICE NUMBER - 30000624023

Scan for a safe and
 secure payment



Amount Enclosed: \$

50100006240234 0004798 00047983 5

Please send payment to:

Primo Brands™
 Blue-Tip™ Brands, Inc.
 P.O. Box 856680
 Louisville, KY 40285-6680



PRIMO BRANDS



ADDRESS SERVICE REQUESTED
 THE PRESERVE AT WILDERNESS LAKE
 AP
 250 INTERNATIONAL PKWY SUITE 206
 STE 200
 LAKE MARY FL 32748-5062





10-S Tennis Supply & Dinkshot Pickleball
 1400 NW 13th Avenue
 Pompano Beach, FL 33069
 Toll-Free: (800) 247-3907
 Local: (954) 969-5440
 www.10-S.com / www.dinkshot.com

Invoice

#175674

Date: 5/18/2026

Bill To

Tish Dobson
 Vesta Property Services
 250 International Pkwy, Suite 208
 Lake Mary FL 32746
 United States

Ship To

The Preserve at Wilderness Lake
 21320 Wilderness Lake Blvd
 Land O'Lakes FL 34637
 United States

Terms	Due Date	PO #	Sales Rep	Ship Via
Due on receipt CC or Check	5/28/2026	Tish Dobson	Kimberly Valencia	Best Way

Quantity	Item	Options	Customer Description	Rate	Amount
44.17	EXT1006-G 10-S DuraPro Extreme 6 (Finished Height 5' 9.5")	Color: Green	1 @ 6'H x 44'2"L, Green, with Standard Half-Moon Vents **Estimated Lead Time - 3 weeks from order date. **Free Shipping **Installation Not Included **Custom Made to Order - No Returns	\$6.95	\$306.98

Subtotal	\$306.98
Shipping Costs (Best Way)	\$0.00
Tax (0%)	\$0.00
Total	\$306.98
Amount Paid	\$0.00
Amount Due	\$306.98



175674

DP Pet Products, LLC
dba ProPet Distributors
5340 Young Pine Rd, Suite 8
Orlando, FL 32829
407-240-0953
sales@propetdistributors.com



DATE	INVOICE #
3/12/2026	2003522

Salesperson:

Bill To:

The Preserve at Wilderness Lake CDD
 Community Development District
 21320 Wilderness Lake Blvd
 Land O Lakes, FL 34637-7879

Ship To:

The Preserve at Wilderness Lake CDD
 21320 Wilderness Lake Blvd
 Land O Lakes, FL 34637

TRACKING NO
889554151596; 889554151600; 889554

P.O. NUMBER	TERMS	DUE DATE	REP	SHIP	VIA	F.O.B.
031126CB	Net 30	4/11/2026	HSE	3/12/2026	FED EX	Orlando,FL

QUANTITY	ITEM CODE	DESCRIPTION	RATE	AMOUNT
3	1402-30	DOGIPOT SMART Litter Pick Up Bags, 200 Opaque Green, 8" x 13" bags per boxed roll - 30 Roll Case	265.74	797.22
2	1404-4	4 PAK - DOGIPOT SMART Liner Trash Bags, 50 count box, heavy duty 1.5 Mil., drawtape, individually-dispensed bags	98.67	197.34
<p><i>To Pay Your Invoice By Credit Card</i> CLICK HERE</p>				

TERMS: A late charge of 1.5% per month will be added on all overdue accounts. Fed TID# 87-3648516



Net Invoice:	994.56
Freight:	165.60
Sales Tax:	0.00
Invoice Total:	1,160.16
Less Deposit:	0.00
Less Payment:	0.00
Invoice Balance:	1,160.16

Thank You for Your Business!



Fitness Logic

380 Scarlet Blvd

Phone #
727-784-4964

Fax #
727-784-0223

E-mail
fitlogic@aol.com

Invoice

Date	Invoice #
5/22/2026	130004

Bill To
Preserve at Wilderness Lake 21320 Wilderness Lake Boulevard Land O' Lakes, FL 34637

Location/Contact/Phone
Preserve at Wilderness Lake 21320 Wilderness Lake Boulevard Land O' Lakes, FL 34637 813-995-2437

P.O. Number	Terms	Rep	Work Order #	Completed
	Net 10	BB	18997	5/21/2026

Item Code	Description	Quantity	Price Each	Amount
Maintenance	Performed Monthly General Maintenance and cleaning of all equipment - Labor Only Maintenance completion during May	1	125.00	125.00

Thank you for your business. Invoices over 30 Days will incur 1.5% Interest per month	Subtotal	\$125.00
	Sales Tax (0.0%)	\$0.00
	Total	\$125.00



05/26/2026

Tish Dobson
Preserve at Wilderness Lake CDD
21320 Wilderness Lake Blvd.
Land O' Lakes, FL 34639

Customer No. MPLCUS113675

Dear Tish Dobson,

Attached below is your new MPLC Certificate of License. Your Blanket License® has automatically renewed in accordance with our underlying agreement. The license fee is \$4,242.70. An invoice is enclosed for your review and payment.

MPLC's Blanket License remains a simple and affordable way to publicly show movies, TV programs, and other content that is intended for personal, private use. Whether streamed, downloaded, broadcasted or shown via your cable TV, DVD or Blu-ray, MPLC's Blanket License helps you ensure copyright compliance in accordance with the US Copyright Act.

Thank you for continuing to support the creative community. Your commitment to compliance helps ensure the future of the entertainment we know and love. If you have any questions, please contact our Member Services Department at (866) 552-MPLC (6752) or online at <https://us.mplc.com/customer-support/>.

Sincerely,

Member Services
info@mplc.com

License Number: 504477145



MPLC Blanket License Certificate

Be it known to Preserve at Wilderness Lake CDD has obtained from MPLC the right to publicly perform, as defined in the U.S. Copyright Act, motion pictures, TV programs and other audio-visual content originally intended for personal use only, via any means including but not limited to DVD, streaming and download, pursuant to the terms and conditions of the Umbrella License Agreement between parties.

The most recent terms and conditions may be found at www.mplc.org.

This Certificate of License expires on: 07/25/2027



Motion Picture Licensing Corporation
 5140 W. Goldleaf Circle, Suite 103
 Los Angeles, CA 90056
 Tel: 866-552-MPLC (6752)
 www.mplc.org

05/26/2026

Invoice No. 504477145

BILL TO: Preserve at Wilderness Lake CDD
 21320 Wilderness Lake Blvd.
 Land O' Lakes, FL
 34639

REMIT TO: Motion Picture Licensing Corporation
 PO Box 80144
 City of Industry, CA 91716-8144

PO No.

CUSTOMER SERVICE: 866-552-MPLC (6752)

QUANTITY	DESCRIPTION	AMOUNT
1	MPLC Blanket License covering the term: 07/26/2026 to 07/25/2027	\$4,242.70
TERMS: PAYABLE 30 DAYS FROM DATE OF INVOICE		
Total		\$4,242.70



[Click here to pay by credit card via Stripe](https://us.mplc.com/pay-an-invoice/) or visit: <https://us.mplc.com/pay-an-invoice/>



Please include Invoice Number on check, payable to MPLC.

NOTE NEW Banking Information: (Please include your invoice number as your payment reference)



Bank: Citibank N.A.
Bank Address: 1 Penns Way, New Castle, Delaware
Routing #/ABA: 031100209
Account Name: Motion Picture Licensing Corporation
Account Address: 5140 W. Goldleaf Circle, Ste. 103, Los Angeles, CA 90056
Account #: 54189195

DETACH AND RETURN BOTTOM PORTION WITH PAYMENT

For contact, address, or delivery method change requests, please visit: mplc.org/currentmembers

PIN # (enter #'s only)	Invoice No	Date	Amount	Amount Due	Paid Amount
MPLCUS113675	504477145	05/26/2026	\$4,242.70	\$4,242.70	\$0.00



PO BOX 66970
 Los Angeles, CA 90066-6970

BILL TO:
 Tish Dobson
 Preserve at Wilderness Lake CDD
 21320 Wilderness Lake Blvd.
 Land O' Lakes, FL 34639

PLEASE REMIT CHECK PAYMENT TO:

Motion Picture Licensing Corporation
 PO Box 80144
 City of Industry, CA 91716-8144



A Total Solution, Inc.
 3487 Keystone Road
 Tarpon Springs, FL 34688

Phone: (727) 942-1993
 www.atotalsolution.com

Bill to
Wilderness Lake Preserve
 C/o Vesta District Services
 250 International Pkwy., Ste208
 Lake Mary, FL 32746

Ship to
Wilderness Lake Preserve
 Wilderness Lake Preserve
 21320 Wilderness Lake Blvd
 Land O Lakes, FL 33543

Work Order Description
 Security Systems Service/Repairs
 Security cameras are sending runaway signals
 Tisha Dobson
 813-7584841

Work Summary
 5/13/26

Upon arrival, tech confirmed with Arcadian that this was not a runaway signal issue. The customer's account is limited to 1,000 events per month, and that limit was exceeded, which generated the invoice.

The main issue appears to be the current schedule programmed with Arcadian, which starts around 9:00–9:30 PM, while approved activities such as the gym and tennis courts may remain open until 10:00–10:30 PM. This is likely causing excessive activity events after hours.

An email was sent to Tisha requesting the correct monitoring schedule so it can be updated. Tech also contacted Arcadian, to verify why Tisha has not been receiving notification calls or texts regarding these events but still waiting for a response.

Once the schedule is corrected, the number of events should decrease significantly, and at this time tech does not believe a higher event plan is necessary.

Work Order #: 13083 Transaction Date: 5/13/2026 Invoice Due Date: 6/12/2026

Invoice #: i10612

Task: SEC-Service

Description	Quantity
Excessive Signals	1

Subtotal: \$223.00
 Tax: \$0.00
 Total: \$223.00

E-mail: accountsreceivable@atotalsolution.com



A Total Solution, Inc.
SECURITY AND FIRE PROTECTION

A Total Solution, Inc.
3487 Keystone Road
Tarpon Springs, FL 34688

Phone: (727) 942-1993
www.atotalsolution.com

Payments:	\$0.00
Balance Due:	\$223.00



INVOICE

Date of Issue: 5/28/26

10751 Maple Creek Dr. Suite 102, Trinity, FL 34655
 Phone: (727) 376-8770 | <https://granthemond.com>

INVOICE ID: 469531-1074

ACCOUNT NO.: 412288

Billed To:

Ms. Tish Dobson
 Wilderness Lake Preserve Lodge
 21320 Wilderness Lake Blvd
 Land O' Lakes, FL 34637

Event Details:

Pool Party
 Community Celebration
 Saturday, June 6, 2026
 Wilderness Lake Preserve
 1:00 PM - 3:00 PM (2 hours)

Balance Due:

\$416.50

List of Services

PACKAGE:

Hours of Service	Description	Price
2	DJ/MC services and dancefloor lighting to enhance the party atmosphere.	\$595.00

ADD-ONS:

Quantity	Description	Price

Total Price: \$595.00

Payments Received: (\$178.50)

Payment Schedule

PAYMENT	AMOUNT DUE	MAKE PAYABLE TO	DUE DATE
Deposit	\$178.50	Grant Hemond and Associates, Inc. PAID 3/31/26	3/29/2026
2nd Scheduled Payment	\$0.00	Grant Hemond and Associates, Inc.	
3rd Scheduled Payment	\$0.00	Grant Hemond and Associates, Inc.	
Final Balance Due	\$416.50	Your DJ - Cody Thompson	6/6/2026



10751 Maple Creek Dr. Suite 102, Trinity, FL 34655
 Phone: (727) 376-8770 | <https://granthemond.com>

INVOICE

Date of Issue: 5/28/26

INVOICE ID: 469532-1075

ACCOUNT NO.: 412288

Billed To:

Ms. Tish Dobson
 Wilderness Lake Preserve Lodge
 21320 Wilderness Lake Blvd
 Land O' Lakes, FL 34637

Event Details:

Independence Day BBQ
 Community Celebration
 Saturday, July 4, 2026
 Wilderness Lake Preserve
 1:00 PM - 3:00 PM (2 hours)

Balance Due:

\$346.50

List of Services

PACKAGE:

<i>Hours of Service</i>	<i>Description</i>	<i>Price</i>
2	DJ/MC services and dancefloor lighting to enhance the party atmosphere.	\$495.00

ADD-ONS:

<i>Quantity</i>	<i>Description</i>	<i>Price</i>

Total Price: \$495.00

Payments Received: (\$148.50)

Payment Schedule

PAYMENT	AMOUNT DUE	MAKE PAYABLE TO	DUE DATE
Deposit	\$148.50	Grant Hemond and Associates, Inc. PAID 3/31/26	3/29/2026
2nd Scheduled Payment	\$0.00	Grant Hemond and Associates, Inc.	
3rd Scheduled Payment	\$0.00	Grant Hemond and Associates, Inc.	
Final Balance Due	\$346.50	Your DJ - ***GHA DJ TBD***	7/4/2026

EXHIBIT 10



Cooper Pools Inc
 4740B Allen Rd PMB
 Zephyrhills, FL 33541

info@cooperpoolsinc.com
 www.cooperpoolsinc.com
 License No. CPC1459240

QUOTE No. 1039

Order No. 1039
 Valid for 30 days

Wilderness Lake Preserve

21320 Wilderness Lake Boulevard
 Land O' Lakes, FL, 34637

Site: 21320 Wilderness Lake
 Boulevard Land O' Lakes

Site Contact:

Salesperson: Andrew Burkett

Date: 06/12/2026

New Inline Thermometer

14648 - Commercial Installation / Repairs

Item	Quantity	Unit Price	Total
L1DW 30-130°F NYLON WELL INLINE THERMOMETER	1.00	\$122.22	\$122.22
Commercial installation / Labor	1.00 hrs	\$180.00	\$180.00
Sub-Total ex Tax			\$302.22
Tax			\$0.00
Total inc Tax			\$302.22



Cooper Pools Inc
 4740B Allen Rd PMB
 Zephyrhills, FL 33541

info@cooperpoolsinc.com
 www.cooperpoolsinc.com
 License No. CPC1459240

QUOTE No. 1054

Order No. 1054
 Valid for 30 days

Wilderness Lake Preserve

21320 Wilderness Lake Boulevard
 Land O' Lakes, FL, 34637

Site: 21320 Wilderness Lake
 Boulevard Land O' Lakes

Site Contact:

Salesperson: Theresa Bonnell

Date: 06/15/2026

Installation of new filter grids

14663 - Commercial Installation / Repairs

Item	Quantity	Unit Price	Total
19" DE Spin Grid Filter Disc	52.00	\$50.00	\$2,600.00
Commercial installation / Labor	2.50 hrs	\$180.00	\$450.00
Sub-Total ex Tax			\$3,050.00
Tax			\$0.00
Total inc Tax			\$3,050.00

EXHIBIT 11

RESOLUTION 2026-05

A RESOLUTION OF THE BOARD OF SUPERVISORS OF THE PRESERVE AT WILDERNESS LAKE COMMUNITY DEVELOPMENT DISTRICT DESIGNATING CERTAIN OFFICERS OF THE DISTRICT, AND PROVIDING FOR AN EFFECTIVE DATE

WHEREAS, the Preserve at Wilderness Lake Community Development District (“District”) is a local unit of special-purpose government created and existing pursuant to Chapter 190, Florida Statutes; and

WHEREAS, the Board of Supervisors of the District desires to designate certain Officers of the District.

NOW, THEREFORE, BE IT RESOLVED BY THE BOARD OF SUPERVISORS OF THE PRESERVE AT WILDERNESS LAKE COMMUNITY DEVELOPMENT DISTRICT:

SECTION 1. _____ is appointed Chairman.

SECTION 2. _____ is appointed Vice Chairman.

SECTION 3. Ellen Dobson is appointed Secretary.
_____ is appointed Assistant Secretary.
_____ is appointed Assistant Secretary.
_____ is appointed Assistant Secretary.
Jacquelyn Leger is appointed Assistant Secretary.
Christine Richie is appointed Treasurer.
Patricia Kehr is appointed Assistant Treasurer.
Scott Smith is appointed Assistant Treasurer.

SECTION 4. This Resolution shall become effective immediately upon its adoption.

PASSED AND ADOPTED this 1st day of July, 2026.

ATTEST:

PRESERVE AT WILDERNESS LAKE COMMUNITY DEVELOPMENT DISTRICT

Secretary/Assistant Secretary

Chairperson/Vice Chairperson, Board of Supervisors

EXHIBIT 12

RESOLUTION 2026-06

A RESOLUTION BY THE BOARD OF SUPERVISORS OF THE PRESERVE AT WILDERNESS LAKE COMMUNITY DEVELOPMENT DISTRICT DESIGNATING SIGNATORIES FOR THE DISTRICT'S OPERATING BANK ACCOUNT(S); AND PROVIDING AN EFFECTIVE DATE.

WHEREAS, the Preserve at Wilderness Lake Community Development District (the "District") is a local unit of special-purpose government created and existing pursuant to Chapter 190, *Florida Statutes*, being situated entirely within Pasco County, Florida;

WHEREAS, pursuant to Chapter 190, Florida Statutes, the funds of the District shall be disbursed by the Treasurer and by other such person(s) as may be authorized by the Board; and

WHEREAS, the Board has previously established a local operating bank account for the District; and

WHEREAS, the Board has previously designated authorized signatories on the bank account; and

WHEREAS, the Board desires to rescind and repeal the prior designation and designate new signatories on the account.

NOW BE IT THEREFORE RESOLVED BY THE BOARD OF SUPERVISORS OF THE PRESERVE AT WILDERNESS LAKE COMMUNITY DEVELOPMENT DISTRICT THAT:

SECTION 1. Vesta District Services is directed to maintain a local bank account for the District.

SECTION 2. Christine Richie, Treasurer, Patricia Kehr, Assistant Treasurer, and Scott Smith, Assistant Treasurer, shall be appointed as signors on the account.

SECTION 3. Christine Richie, Treasurer and Patricia Kehr, Assistant Treasurer, and Scott Smith, Assistant Treasurer, are authorized to open and close accounts and transfer the funds if needed as set forth herein or as otherwise directed by the Board.

SECTION 4. All previous signers on the District's accounts shall be automatically removed effective as of July 1, 2026.

SECTION 5. This Resolution shall take effect on July 1, 2026, and shall remain in effect unless rescinded or repealed.

PASSED AND ADOPTED this 1st day of July, 2026.

ATTEST:

**PRESERVE AT WILDERNESS LAKE
COMMUNITY DEVELOPMENT
DISTRICT**

Secretary/Assistant Secretary

Chair, Board of Supervisors

EXHIBIT 13

Jonathan J. Ellis, Esq.
Shareholder
Board Certified Specialist, Condominium and Planned
Development Law
Phone: 813.954.8454 Fax: 813.286.7683
jellis@beckerlawyers.com

Becker

1511 N. Westshore Blvd.
Suite 1000
Tampa, FL 33607

June 17, 2026

Via Regular U.S. Mail
and Email: tdobson@vestapropertyservices.com

Tish Dobson, Manager
Preserve at Wilderness Lake Community Development District
250 International Parkway, Suite 208
Lake Mary, FL 32746

Re: November 1, 2018 Irrigation and Maintenance Cost Sharing Agreement

Dear Ms. Dobson:

Please consider this correspondence as a follow up to our June 2, 2026 correspondence in the above-referenced matter. The Wilderness Lake Preserve Homeowners' Association, Inc. (the "Association") is currently in receipt of your June 9, 2026, email correspondence regarding repair costs arising out of Nature's Ridge, Lakewood Retreat, and Deerfield's irrigation systems. Specifically, in your email, you indicate "once the repairs are completed, we [the District] will issue an invoice for reimbursement."

The Association has reviewed the parties' November 18, 2023, Irrigation and Maintenance Cost Sharing Agreement ("Agreement"). Paragraph 3 of the Agreement states as follows:

3. **Cost Sharing.** The parties acknowledge and agree that the District shall pay for routine operation and maintenance of The Preserve Community Irrigation System. The Association shall be responsible for any costs beyond routine operation and maintenance activities such as major irrigation line repairs, replacements or re-configurations in the gated common areas.

Pursuant to the Agreement, maintenance relating to broken nozzles, broken drip lines, and clogged Maxijet nozzles should fall within the District's obligation to pay for "routine operations and maintenance." As a result, the Association requests you confirm that this is an expense borne by the District and that the Association will not receive an invoice for reimbursement.

Preserve at Wilderness Lake Community Development District

June 17, 2026

Page 2

Should you have questions, or would like to discuss this matter, please feel free to contact me.

Sincerely,

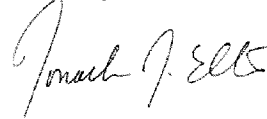

Jonathan J. Ellis

JJE/lb

c: Wilderness Lake Preserve Homeowners' Association, Inc.

Straley, Robin and Vericker
1510 W. Cleveland St.
Tampa, FL 33606

EXHIBIT 14



Price Quotation

SPECIALTY SURFACES, LLC.

3899 Mannix Dr. Suite 424
 Naples, FL 34114-5411
 Phone 239-352-7151
 Fax 239-352-7153

Date: 06/10/26
 Quote Expiration Date: 09/08/26

Sales Rep: Nikki Barney
 nbarney@specialtysurfacesllc.com
 Cell: 407-925-7873

specialtysurfacesllc.com

Contact Name: Tish Dobson Customer Name: Wilderness Lakes Preserve Street Address: 21320 Wilderness Lake Blvd City, ST. & Zip Land o Lakes FL 33607 Office: 813-995-2437 Cell: Email: tdobson@wplodge.com	Site Contact: 0 Job Name: Local Repairs (Labor only) of Rubber Deck Street Address: City, ST. & Zip Office: Cell: Email:
---	--

Installation Product Description	Critical Fall Height	Total System Height (inches)	Quantity / Square Footage	NOTES	Amount
Local Repairs of Existing Rubber Deck on Splash pad	N/A	0.375		approximately 7 small areas Rubber granules provided by Wilderness Lodge	1,350.00
ADD Option: Deep Clean and Roll Coat 2 part urethane binder on all				Add \$ 3,150 to total below.	

Terms: 50% Due upon acceptance / 50% to be paid upon completion **TOTAL: 1,350.00**

Price quoted includes all materials, shipping and installation - Any difference in final SF will be reflected in the final price.
 Price does not include Custom Design Work, Prevailing Wage Rates and Field Security if required unless noted above.
 Trash and / or Demolition remains will be bagged and disposed of in a customer supplied dumpster unless otherwise agreed on.
 Department of Health Variance AND FEES may be required and is the sole responsibility of the Owner or General Contractor.
 Price is not inclusive of on site storage or container fees unless otherwise noted above.
 Pebble Flex is only installed on flat surface, it will terminate at the tangent point of the radius.
 Sales Tax is NOT included unless noted above.
 The price reflected in this quote is valid for 60 days from date of this quote as noted above.
 All Permits and/or fees are the sole responsibility of the Owner or General Contractor.
 Customer is responsible to provide an adequate dumpster on site if required.

EXHIBIT 15

EXHIBIT 15A



Advanced Recreational Concepts, LLC

3127 Skyway Circle # 101
Melbourne, FL 32934

Phone: 321-775-0605 / Fax: 321-242-2216

Proposal

Organization **Wilderness Lake Preserve CDD**
21320 Wilderness Lake Blvd
Lakeland, FL 34637

Prepared For **Tish Dobson**
Ship To **Oakhurst Park**
TBD
Land O Lakes, FL 34637

Date **4/30/2026**
Quotation # **27947**
Prepared By **Matt Gagnon**
Payment Terms **Net 30**
Prices Valid Until **5/30/2026**
Project Name **Pavilion**
Customer Phone
County **Pasco**

Product ID	Description	Qty	U/M	Price	Total
	PROPOSAL BASED ON SUPPLY & DELIVERY. INSTALLATION SEPARATE ON PSS # 27222				0.00
	Model #: RHS 1212 Rectangular Hip Shelter 12' x 12' with 8' Eave	1		18,820.00	18,820.00T
	Freight	1		4,935.00	4,935.00
	Florida Signed and Sealed Drawings (3 Sets) CALCULATIONS provided.	1		1,000.00	1,000.00

100% Financing Available – Flexible Terms
Ask Your ARC Sales Representative For More Information

Subtotal \$24,755.00
Sales Tax (0.0%) \$0.00
Total \$24,755.00

Signature _____ Print Name/Title _____ Date _____ P.O. # _____

Upon acceptance of this proposal please sign above and initial the 'ARC Site Preparation Check List' and the 'ARC General Terms and Conditions' exhibits attached. Please return initialed copies to ARC.



3127 Skyway Circle # 101
 Melbourne, FL 32934
 Phone 1-321-775-0600 Fax 1-321-242-2216
 Toll Free - 888-653-7529

PROPOSAL

Date: 4/30/2026

Proposal # 27222

Prepared for: T. Dobson

Payment Terms: Net 30

Customer Phone:

Proposal Valid Until: 5/30/2026

Customer Fax:

Organization: Wilderness Lake Preserve CDD
 21320 Wilderness Lake Blvd
 Lakeland, FL 34637

Project: Pavilion
 Ship To: Oakhurst Park
 TBD
 Land O Lakes, FL 34637

Sales Rep M T G

Scope of Services:

DESCRIPTION
INSTALLATION IS BASED ON ARC PROPOSAL # 27947
Installation of: - (1) 12' x 12' Hip Shelter
(Price includes concrete for footers and rental equipment)
TOTAL: \$13,895.00
Installation of 16' x 16' Concrete Slab Approx. 256 Sq Ft
TOTAL: \$5,120.00
Removal and Disposal of: - Existing Pavilion and Footers - Existing 16' x 16' Concrete Slab
(Price includes rental equipment)
TOTAL: \$8,545.00
Permitting and Administration Fees
TOTAL: \$1,500.00

Subtotal \$29,060.00

Sales Tax (0.00) \$0.00

TOTAL \$29,060.00

Signature: _____ ... Print Name/Title: _____ Date _____ P.O. # _____

The above quotation is based upon site access for heavy equipment and soil conditions of 2000 PSI. If during excavation of foundations necessary per manufactureres specifications conditions exceed normal, our contractor shall notify the owner immediately. This shall include all types of rock, vegetation and any unforeseen hazards. There will be additional charges incurred to clear the area and or the abutement hole so that installation can be completed.

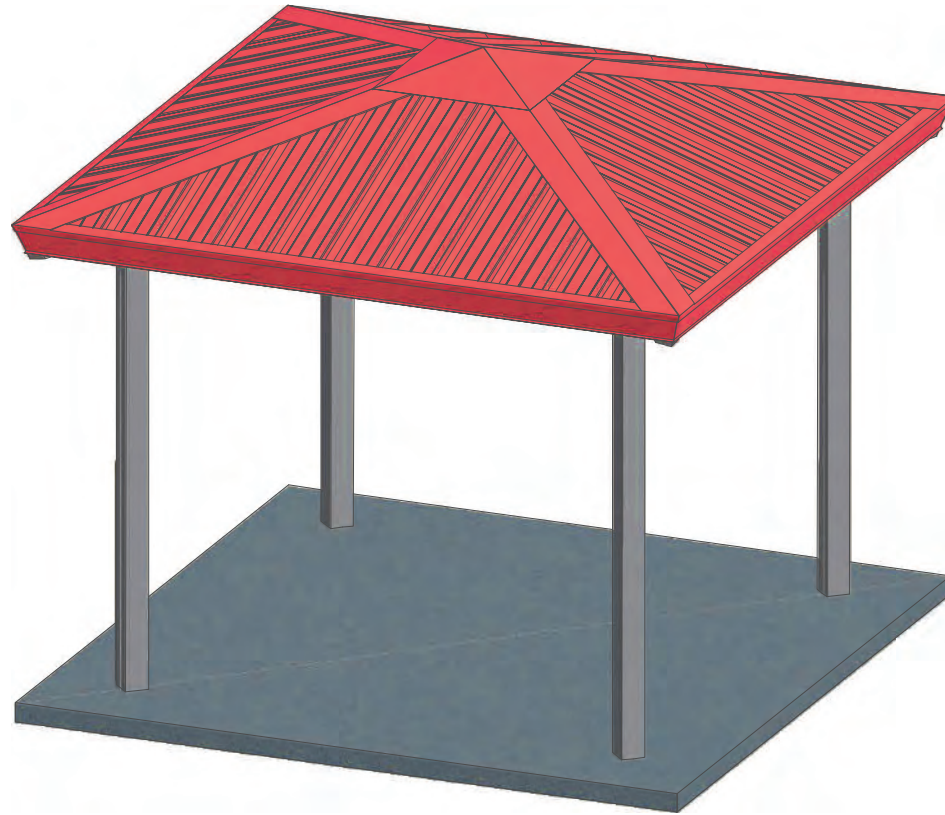

P.O. BOX 145

WEST OLIVE, MI 49460

800-552-9495

CEDAR FOREST PRODUCTS WWW.CEDARFORESTPRODUCTS.COM

DESCRIPTION:	MODEL #:	DATE:	DESIGNER:	REV:
12'x 12' Rect Hip Shelter	RHS1212	3/16/2022	JES	0

SCALE: NTS

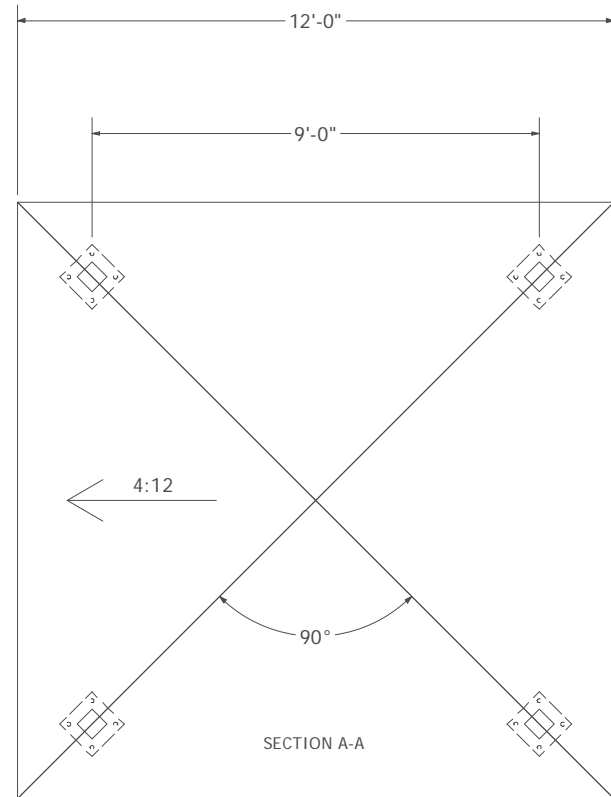
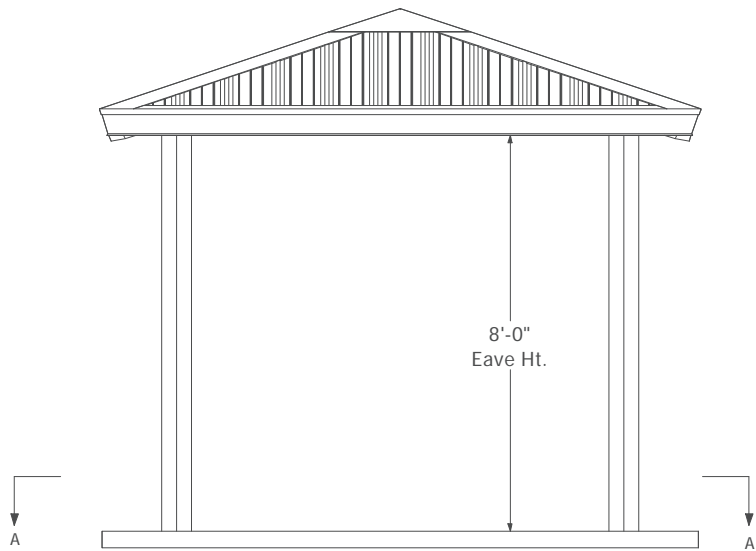

P.O. BOX 145

WEST OLIVE, MI 49460

800-552-9495

CEDAR FOREST PRODUCTS WWW.CEDARFORESTPRODUCTS.COM

PRELIMINARY LAYOUT
NOT FOR CONSTRUCTION

DESCRIPTION:	MODEL #:	DATE:	DESIGNER:	REV:
12'x 12' Rect Hip Shelter	RHS1212	3/16/2022	JES	0

PRELIMINARY MEDIUM FOOTING

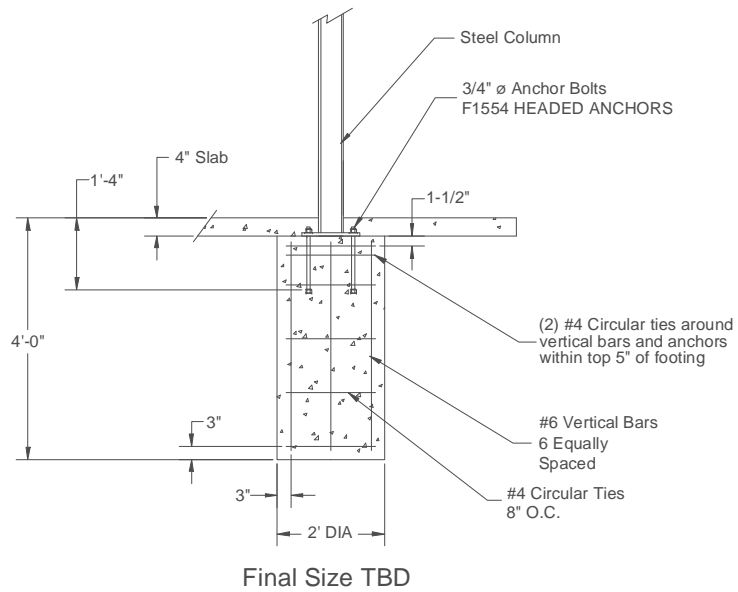

PRELIMINARY LARGE FOOTING

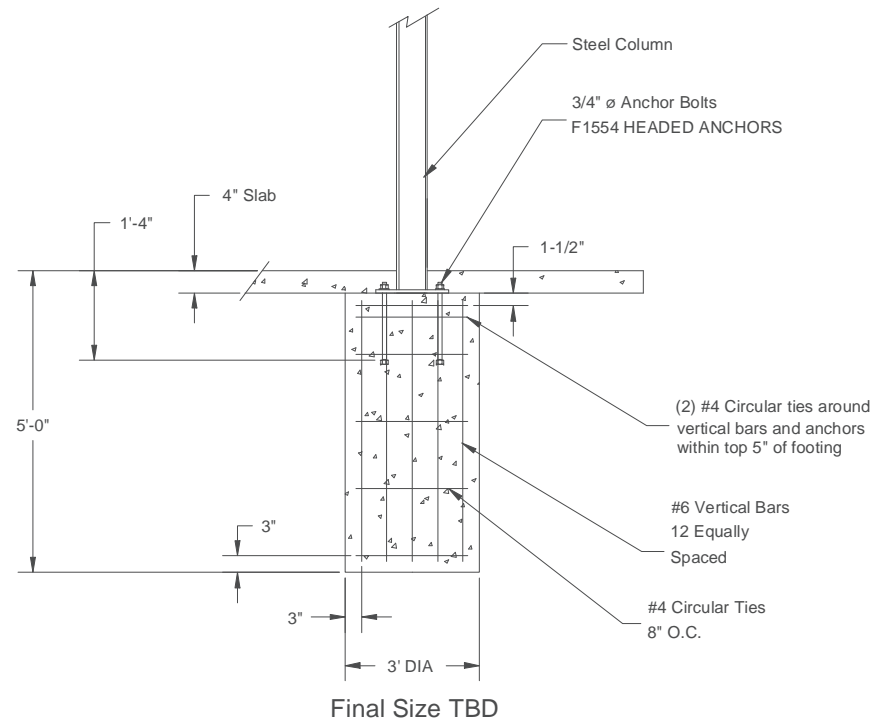

P.O. BOX 145

WEST OLIVE, MI 49460

800-552-9495

CEDAR FOREST PRODUCTS WWW.CEDARFORESTPRODUCTS.COM

PRELIMINARY LAYOUT
NOT FOR CONSTRUCTION

DESCRIPTION:	MODEL #:	DATE:	DESIGNER:	REV:
12'x 12' Rect Hip Shelter	RHS1212	3/16/2022	JES	0

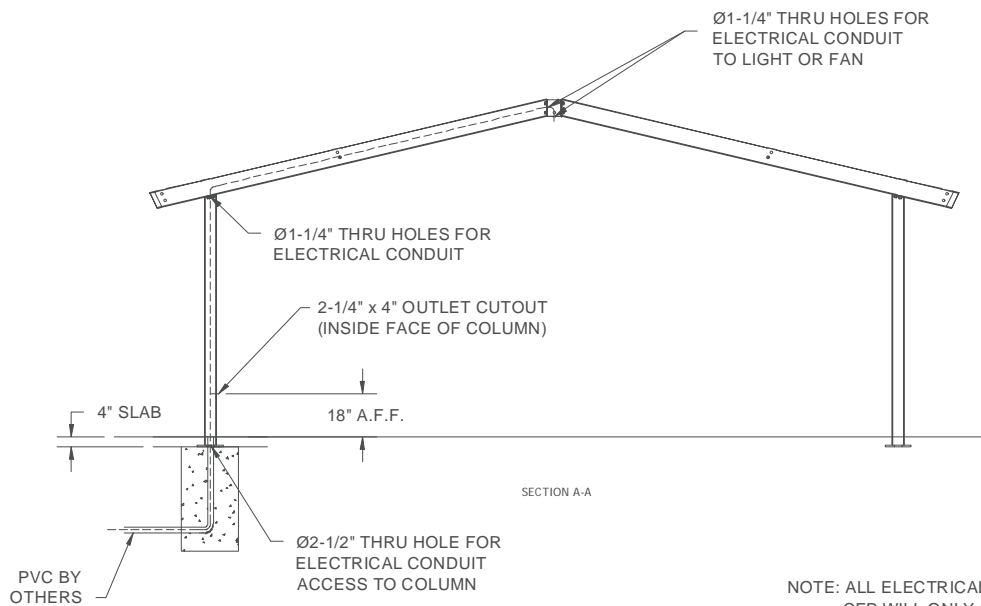
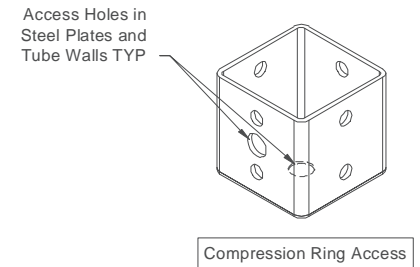
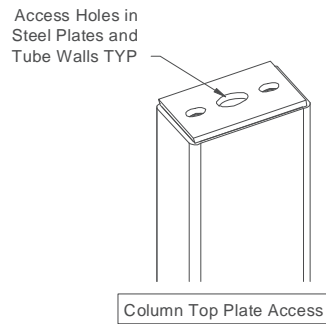
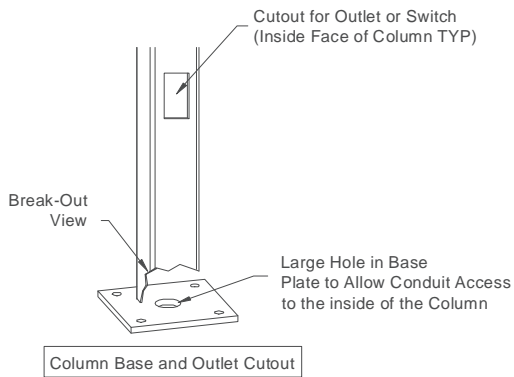

NOTE: ALL ELECTRICAL COMPONENTS BY OTHERS
CFP WILL ONLY SUPPLY THE CUTOUTS/HOLES IN THE STEEL

PRELIMINARY LAYOUT
NOT FOR CONSTRUCTION



P.O. BOX 145

WEST OLIVE, MI 49460

800-552-9495

CEDAR FOREST PRODUCTS WWW.CEDARFORESTPRODUCTS.COM

DESCRIPTION:	MODEL #:	DATE:	DESIGNER:	REV:
12'x 12' Rect Hip Shelter	RHS1212	3/16/2022	JES	0

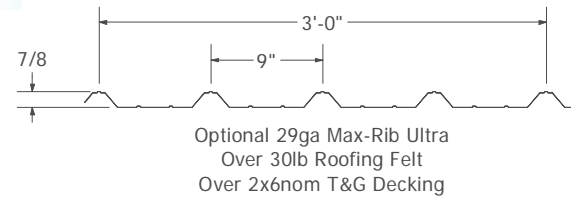
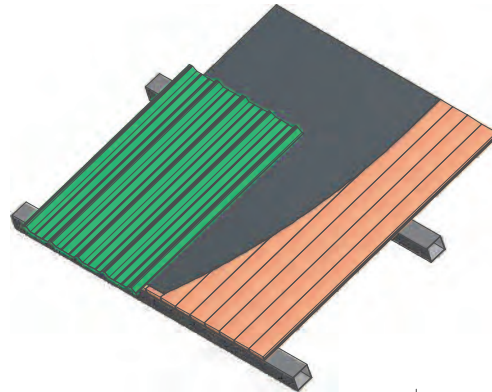
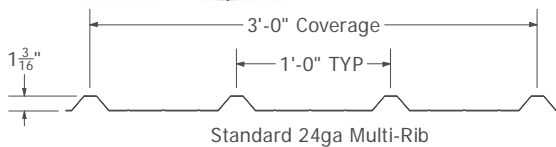
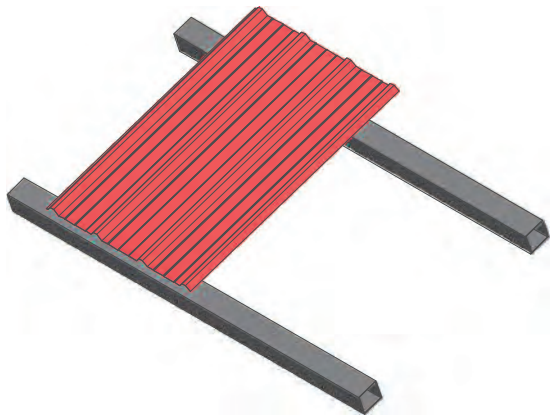

*Layouts are to Show
the Optional Roofing,
Not for Installation Practices*

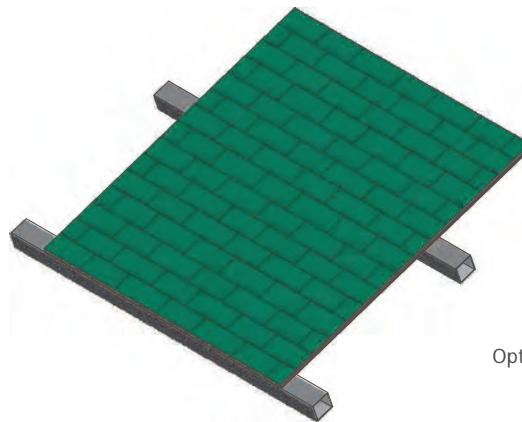
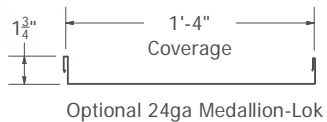
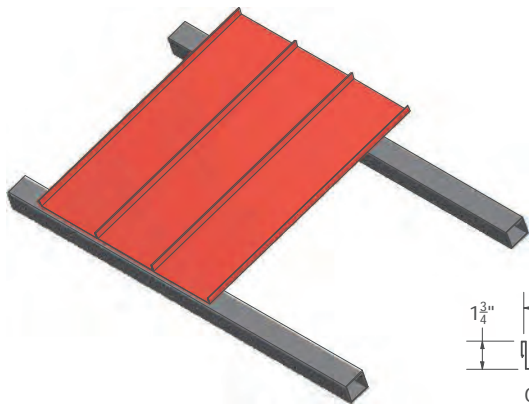

Optional Asphalt or Cedar Shingles
Over 30lb Roofing Felt
Over 2x6nom T&G Decking



P.O. BOX 145
WEST OLIVE, MI 49460
800-552-9495
WWW.CEDARFORESTPRODUCTS.COM

PRELIMINARY LAYOUT
NOT FOR CONSTRUCTION

DESCRIPTION:	MODEL #:	DATE:	DESIGNER:	REV:
12'x 12' Rect Hip Shelter	RHS1212	3/16/2022	JES	0

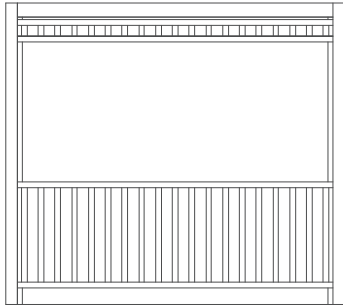

HP-1

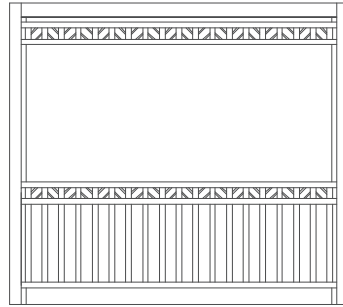

HP-2

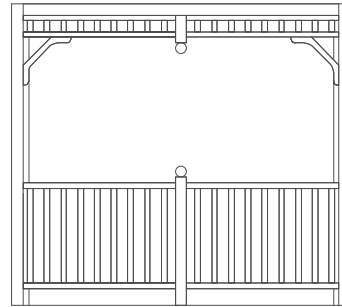

HP-3

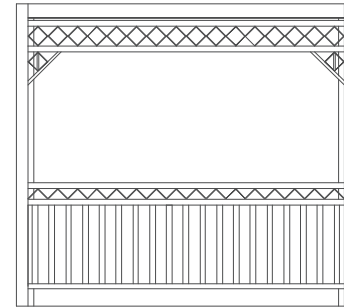

HP-4

OPTIONAL PATTERNS

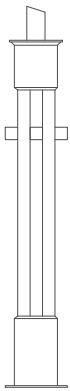

Optional Quad Column

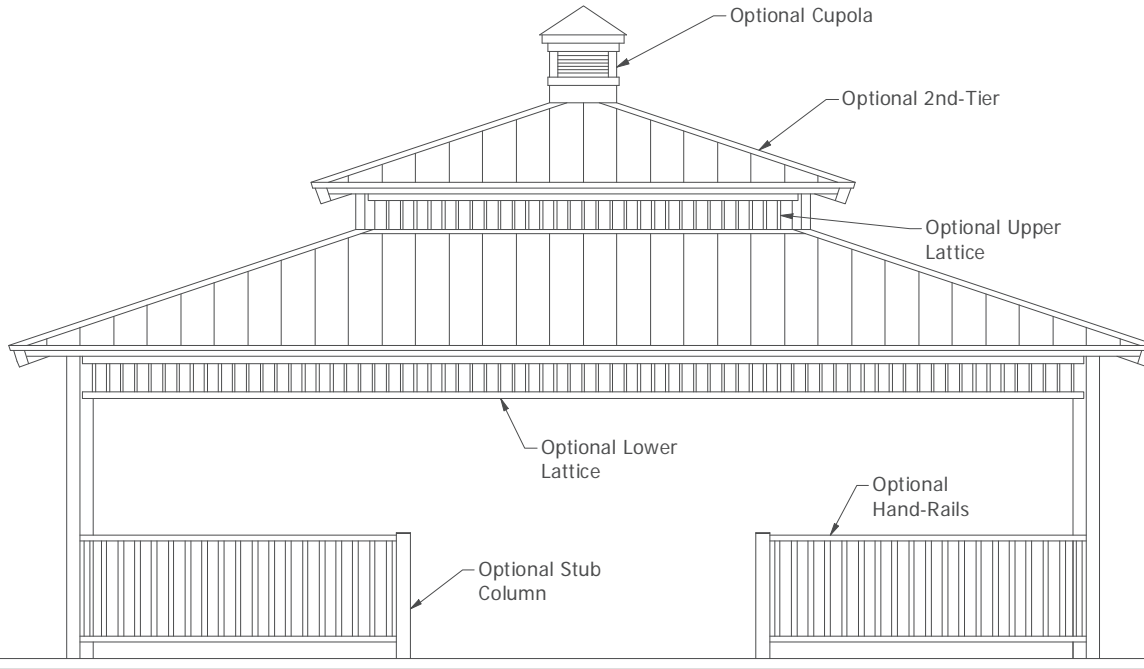

Optional Round Column
Shown w/Optional Bands



CEDAR FOREST PRODUCTS WWW.CEDARFORESTPRODUCTS.COM

P.O. BOX 145

WEST OLIVE, MI 49460

800-552-9495

PRELIMINARY LAYOUT

NOT FOR CONSTRUCTION

DESCRIPTION:	MODEL #:	DATE:	DESIGNER:	REV:
12'x 12' Rect Hip Shelter	RHS1212	3/16/2022	JES	0

EXHIBIT 15B

Project Innovations Inc
712 Wesley Ave Building A
Tarpon Springs FL 34689
727-460-8449

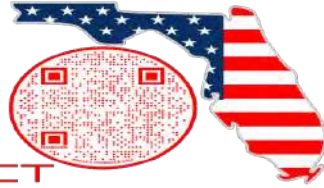

PROJECT INNOVATIONS INC
 PLAY FOR A DAY LEARN FOR A LIFETIME

Date: June 2, 2026

Bill To:
Wilderness lake
21320 Wilderness lake Blvd
Land O Lakes FL 34637

Ship To:
Same

ProjectInnovationsFlorida@gmail.com

Contact #1: <u>Tish Dobson</u>	Phone: <u>813-995-2437</u>	Email: _____
Contact #2: _____	Mobile: _____	Email: _____

Qty.	Item #	Description/Colors/Mounting/Etc...	MSRP	Total
1	CUSTOM	Custom Size Pavillion 11 X 11 Steel Square Shelter Installed FL Certified Drawings Frame Powder Coated Brown Roof 24 ga Mega Rib Green Color Eave 8' Roof Pitch 4:12 Concrete Embeddment w/ Anchor 18' X 18' Slab @ 4" Thick	\$ 50,500.00	\$ 50,500.00
1	PERMIT	Permit cost TBD to be reimbursed		

Not responsible for irrigation lines or any sod replacement	REFERENCE #	Sub Total \$ 50,500.00
--	--------------------	-------------------------------

Order Approved By (signature): _____
 Date: _____

Total \$50,500.00

Quote is valid for 30 days on all equipment and install. Quote is valid for 10 days on all freight. Quote excludes site preparation. The customer is responsible for locating all underground phone & utility lines 72 hours prior to the installation date by calling 811. By initialing, customer acknowledges that any damage done as a result of not locating these lines will be the customers liability. (Initial) _____

Without FULL installation, customer is responsible for arranging for the off-loading of equipment & check-in. If during installation, large rocks or concrete are found additional costs for removal will occur. Additional expenses must be approved by both parties. All customers are required to pay local and state taxes. If a customer has tax exempt status, Project Innovations Inc must retain a copy of 501(C)(3) or other proof of tax exempt status.

PRELIMINARY DRAWING – NOT FOR CONSTRUCTION

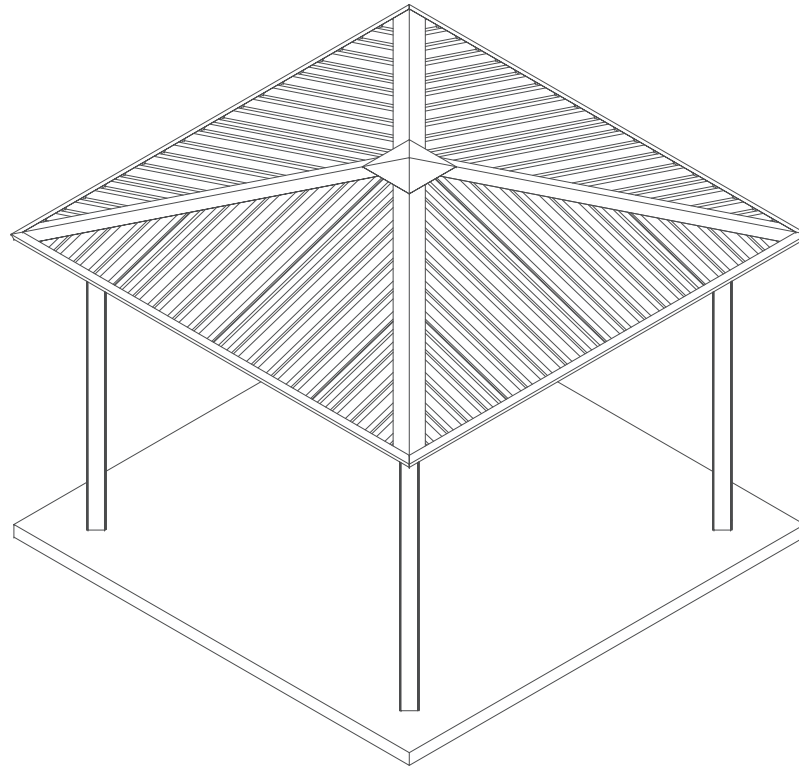
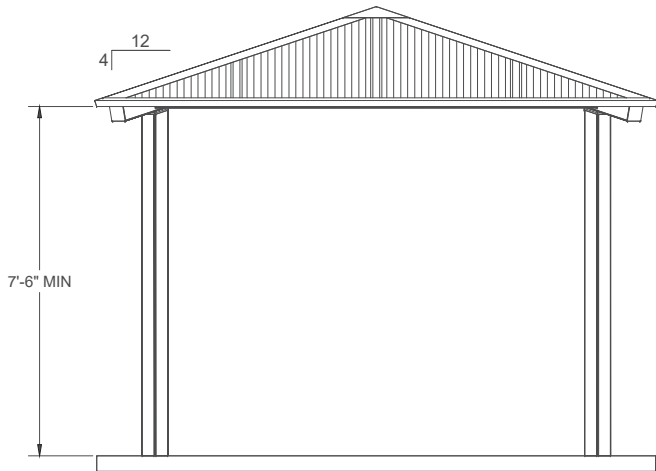
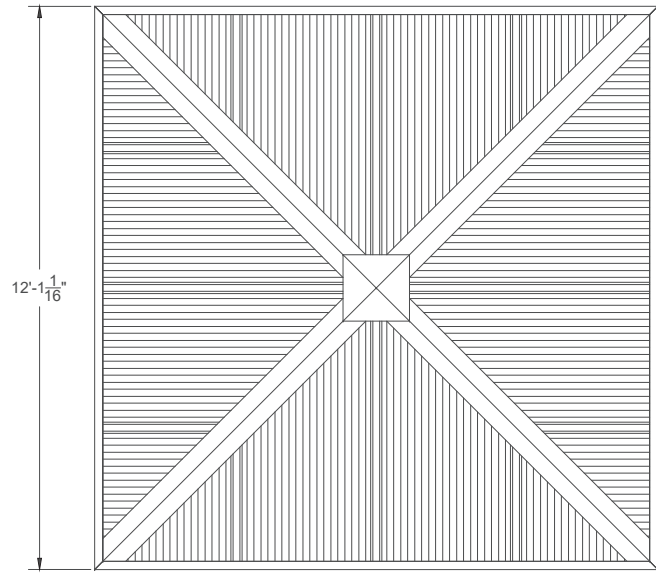

THIS PRINT IS THE PROPERTY OF RCP SHELTERS AND IS NOT TO BE COPIED OR REPRODUCED WITHOUT THEIR EXPRESSED WRITTEN PERMISSION.

TS-SQ12-04

RCP SHELTERS, INC.

2100 SE RAYS WAY STUART, FL 34994 PO BOX 25 STUART, FL 34995-0025

- SHELTERS ■ PAVILIONS ■ CONCESSIONS ■ KIOSKS ■ FABRIC SHADE
 - RESTROOMS ■ BANDSHELLS ■ MINI-SHELTERS ■ DUGOUTS ■ FABRIC SAIL
- Phone 800-525-0207 Fax 772-288-0207
 Email info@rcpselters.com
 www.rcpselters.com



PROJ. NO.	
DRAWN	
CHKD	
REV.1	
REV.2	
REV.3	
REV.4	
REV.5	
CAD NO.	
SEC. JOB NO.	
SHEET NO.	

PRELIMINARY DRAWING – NOT FOR CONSTRUCTION

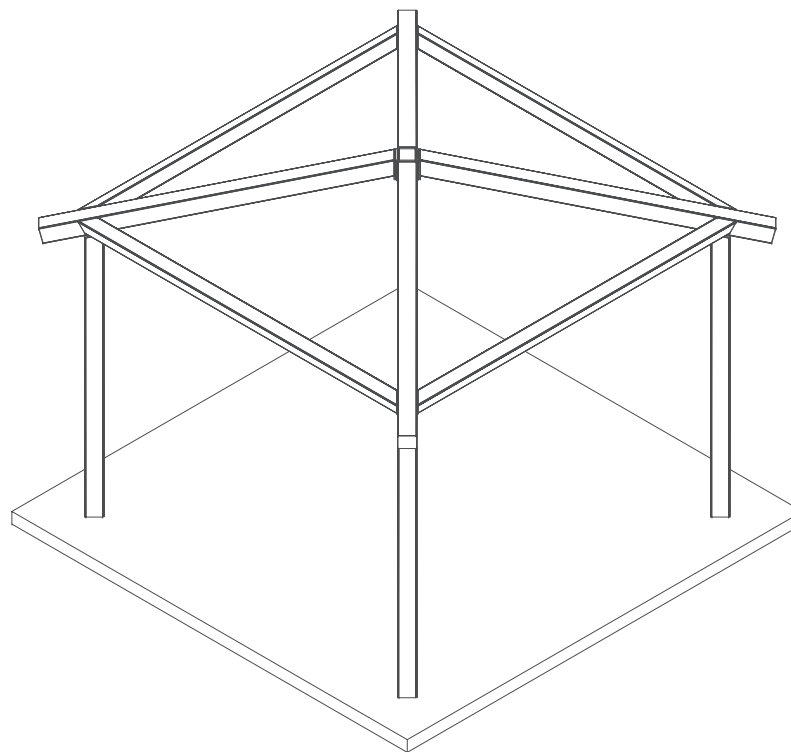
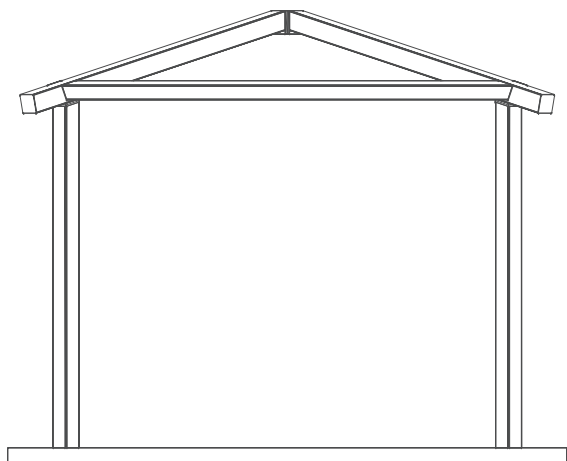
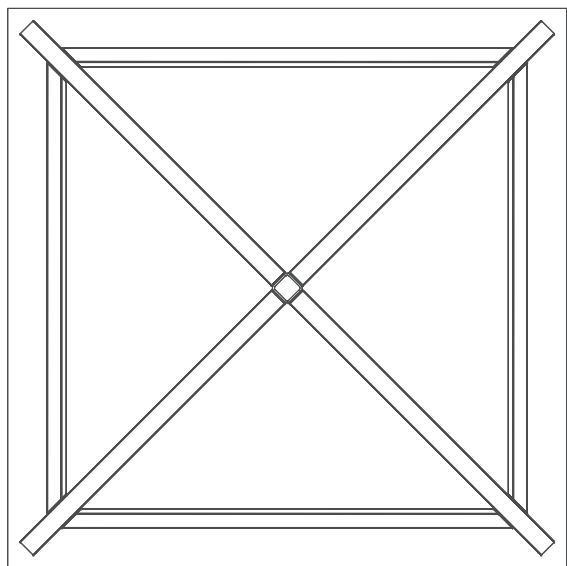

THIS PRINT IS THE PROPERTY OF RCP SHELTERS AND IS NOT TO BE COPIED OR REPRODUCED WITHOUT THEIR EXPRESSED WRITTEN PERMISSION.

TS-SQ12-04

RCP SHELTERS, INC.

2100 SE RAYS WAY, STUART, FL 34994 PO BOX 25 STUART, FL 34995-0025

- SHELTERS ■ PAVILIONS ■ CONCESSIONS ■ KIOSKS ■ FABRIC SHADE
- RESTROOMS ■ BANDSHELLS ■ MINI-SHELTERS ■ DUGOUTS ■ FABRIC SAIL

Phone 800-525-0207 Fax 772-288-0207

www.rcpselters.com Email info@rcpselters.com

NUMBERS OF PURLINS MAY VARY DEPENDENT UPON DESIGN, COLORS, SIZES AND SPACING OF PURLINS TO BE DETERMINED DURING FINAL DESIGN.



PROJ. NO.	
DRAWN	
CHKD	
REV.1	
REV.2	
REV.3	
REV.4	
REV.5	
CAD NO.	
EEC JOB NO.	
SHEET NO.	

PRELIMINARY DRAWING – NOT FOR CONSTRUCTION

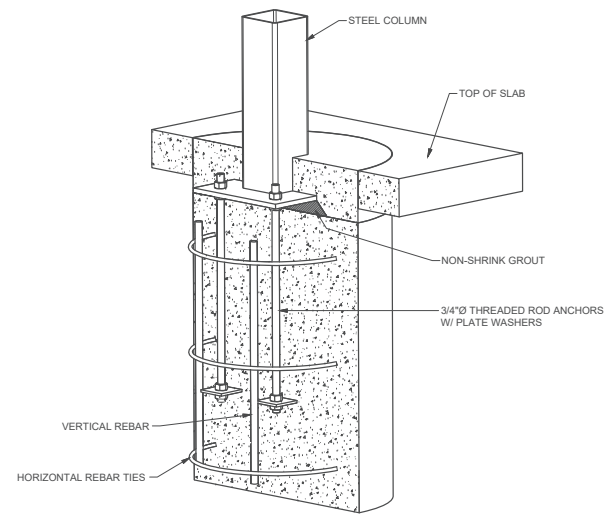
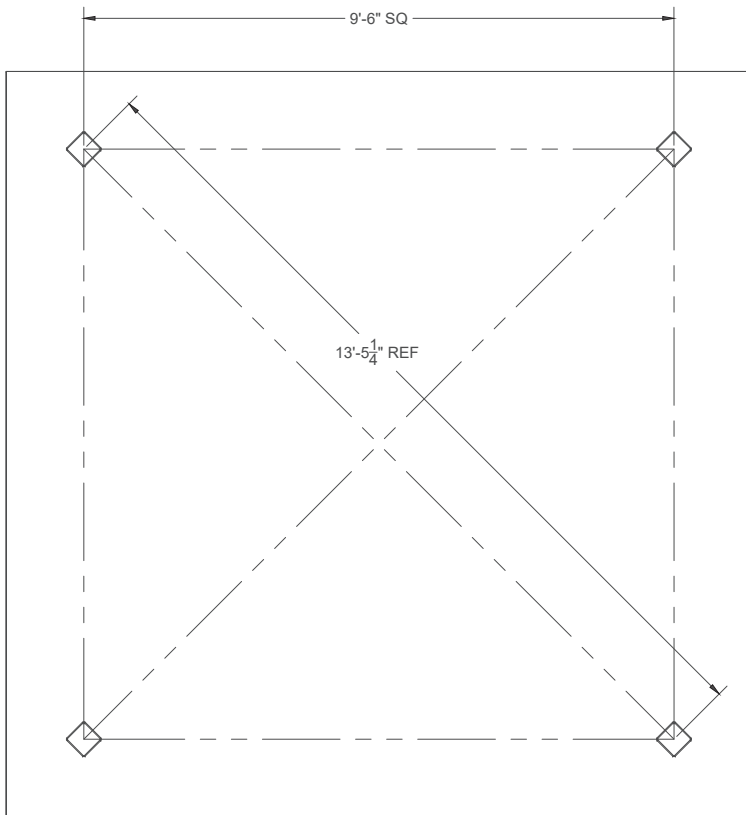

STEEL COLUMN PIER DETAIL

TYPICAL PIER DIAMETER IS BETWEEN 2'-0" AND 3'-0"
 TYPICAL PIER DEPTH IS BETWEEN 3'-6" AND 5'-6"
 ACTUAL DESIGN WILL VARY DUE TO BUILDING CODE REQUIREMENTS AND MAY BE SUBSTANTIALLY LARGER.

THIS PRINT IS THE PROPERTY OF RCP SHELTERS AND IS NOT TO BE COPIED OR REPRODUCED WITHOUT THEIR EXPRESSED WRITTEN PERMISSION.

TS-SQ12-04

RCP SHELTERS, INC.
 2100 SE RAYS WAY, STUART, FL 34994 PO BOX 25 STUART, FL 34995-0025
 SHELTERS ■ PAVILIONS ■ CONCESSIONS ■ KIOSKS ■ FABRIC SHADE
 RESTROOMS ■ BANDSHELLS ■ MINI-SHELTERS ■ DUGOUTS ■ FABRIC SAIL
 Phone 800-525-0207 Fax 772-288-0207
 www.rcpselters.com Email info@rcpselters.com



PROJ. NO.	
DRAWN	
CHKD	
REV.1	
REV.2	
REV.3	
REV.4	
REV.5	
CAD. NO.	
EEC. JOB NO.	
SHEET NO.	

PRELIMINARY DRAWING – NOT FOR CONSTRUCTION



THIS PRINT IS THE PROPERTY OF RCP SHELTERS AND IS NOT TO BE COPIED OR REPRODUCED WITHOUT THEIR EXPRESSED WRITTEN PERMISSION.

TS-SQ12-04

RCP SHELTERS, INC.

2100 SE RAYS WAY STUART, FL 34994 PO BOX 25 STUART, FL 34995-0025

- SHELTERS ■ PAVILIONS ■ CONCESSIONS ■ KIOSKS ■ FABRIC SHADE
- RESTROOMS ■ BANDSHELLS ■ MINI-SHELTERS ■ DUGOUTS ■ FABRIC SAIL

Phone 800-525-0207 Fax 772-288-0207
 Email info@rcpselters.com

www.rcpselters.com



PROJ. NO.	
DRAWN	
CHKD.	
REV.1	
REV.2	
REV.3	
REV.4	
REV.5	
CAD. NO.	
EEC. JOB NO.	
SHEET NO.	

EXHIBIT 16

Site Masters of Florida, LLC
5551 Bloomfield Blvd.
Lakeland, FL 33810
Phone: (813) 917-9567
Email: tim.sitemastersofflorida@yahoo.com

PROPOSAL

Wilderness Lake Preserve CDD

Oakhurst Park - Pavillion Slab

6/24/2026

Demolish and remove 16' x 16' x 4" concrete slab

Sub-total \$1,400

Construct 16' x 16' x 4" concrete slab w/ thickened edge

- Thickened edge will be 12" wide x 10" thick (incl. 4" slab)
and will have 2 (parallel) - #4 steel bars for reinforcement

Sub-total \$5,120

TOTAL \$6,520

NOTES:

- all concrete debris and excess soil will be removed
- scope does not include any irrigation or landscaping/sod
- scope does not include any electrical conduits, etc.

EXHIBIT 17

EXHIBIT 17A



QUOTE #776

SENT ON:

Jun 24, 2026

RECIPIENT:

Wilderness Lake Preserve

21320 Wilderness Lake Boulevard
Land O' Lakes, Florida 34637

SENDER:

Coastal Courts

2164 Platinum Road
Unit B
Apopka, Florida 32703

Phone: 407-822-9955

Email: estimating@coastalcourts.com

Website: www.coastalcourts.com

Product/Service	Description	Qty.	Unit Price	Total
Resurface half basketball court 42 x 50	<ul style="list-style-type: none"> - Power wash and/or machine sand the court(s) to eliminate dirt, mildew, minor imperfections, and raised crack edges. - Clean out the wider structural cracks and fill any cracks exceeding 1/16th of an inch with an acrylic patch mix. - Flood the court(s) and patch all areas retaining water to a tolerance of 1/8 inch after one hour of drainage. - Squeegee one coat of sand-filled acrylic resurfacer over the entire surface. - Squeegee two coats of sand-filled acrylic color over the entire surface, with colors to be selected. - Stripe one half basketball court, ensuring all game lines are 2 inches wide, utilizing textured line paint in accordance with ASBA standards. 	1	\$6,343.00	\$6,343.00
Fiberglass Overlay	Furnish and install 1.8oz fiberglass membrane over the entire court surface. This will create a layer over the existing surface preventing the return premature cracks. *Additional coat of resurfacer is included.	1	\$1,320.00	\$1,320.00

Not included

Total **\$6,343.00**



QUOTE #776

SENT ON:

Jun 24, 2026

Images

View online <https://l.jbbr.io/OUd73ys>



Reviews

Catherine Tagliareni



I cannot say enough great things about Coastal Courts. From start to finish, every single person I worked with was professional, kind, knowledgeable, and incredibly thorough. They were accommodating throughout the entire process and always took the time to make sure every detail was handled correctly. Their pricing was lower than their competitors', and the quality of their work exceeded my expectations. They didn't just improve my court — they made it look and perform better than when it was originally installed. The attention to detail and pr...

Tee Wells



Very responsive and very professional. Outstanding work. Really helped with strategizing what I need and what I didn't need.

Rebecca Rutledge



I am a Property Manager and used Coastal Courts to redo a tennis court in one of my Associations. They were AMAZING!! The end result brought back life to years of deterioration, and the entire community and Board of Directors is very pleased with how it turned out. Rob and Nick are wonderful to work with. Midway through the project we had to adjust the plan, and they came in with their expertise and guidance that really did make a huge difference. I HIGHLY recommend this company and will be using them in the future for any other projects I may ...



QUOTE #776

SENT ON:

Jun 24, 2026

CONDITION OF SALE:

- This quote is valid for the next 30 days, after which values may be subject to change.
- Permits are not included.
- All labor is open shop, court must be accessible with heavy equipment, customer must provide a water source to flood court(s) and mix materials.
- Work can only be completed under acceptable weather conditions. Customer must turn off all sprinklers systems that may cause water to fall upon court(s).
- Coastal Courts is not responsible for damage to vegetation, driveways, sidewalks, curbs, or irrigation systems.
- Coastal Courts guarantees workmanship and material for one year after completion date. This guarantee excludes normal wear and tear, physical abuse or neglect, and any other condition beyond our control such as subbase settling, structural cracks, hydrostatic pressure, water vapor pressure bubbles, and intrusion of weeds or insects. Please note: As asphalt sport court age and weathers, it oxidizes, shrinks, and hardens, making it less flexible and more prone for cracks to reappear and new cracks to form. Coastal Courts does not warranty any new appearing or existing cracks reappearing. Cracks develop on sports courts for several reasons, below are the most common:
 - * Asphalt expands and contracts with temperature fluctuations, causing new cracks to appear and old cracks to reappear, most common in colder months.
 - * Loss of oils in asphalt causing the asphalt to dry out and be less flexible
 - * Changes in base stability, causing a crack reflecting through the surface.

PAYMENT TERMS

1. New Construction and Reconstruction Projects:

A 35% deposit is required to secure materials and schedule the project. A 35% progress payment will be due upon substantial completion of the asphalt or concrete and or fence phase, and the remaining 30% final payment will be due upon project completion.

2. Resurfacing Projects:

A 50% deposit is required prior to scheduling and mobilization. The remaining 50% balance will be due upon completion of the resurfacing work.

Please Note: All deposits are non-refundable once materials have been ordered or work has commenced. Payment must be made according to the schedule above to avoid project delays.

Signature: _____ Date: _____

EXHIBIT 17B



FLORIDA COURTS, INC.
6820 HUDSON AVE.
HUDSON, FL 34667
727-861-0004

www.floridacourtsinc.com

PROPOSAL B
PAGE 1 OF 3

AGREEMENT

DATE: 6/20/26

CONTACT: Tish Dobson (General Manager) ph# 813-995-2437
Email: manager@wplodge.com

LOCATION: Wilderness Lake Preserve - 21320 Wilderness Lake Blvd. - Land O Lakes, FL 34637

CONDITIONS: Resurface 1 half basketball court with a 4 coat system Size: 50' x 42'

NOTE: The \$4,800. price below is the cost if resurfacing the court at the same time as the tennis courts. If this is to be resurfaced at another time, the cost will be \$9,600.

1. Florida Courts will first **pressure wash any mildew off** the court to provide a proper base for adhesion of resurfacing materials.
2. Florida Courts will **flood the court** and check for puddles where standing water covers 1/8" in depth (thickness of a nickel) after the surface has been able to dry, under sunny conditions, for 1 hour. We will then **patch these areas with Acrylic Patch Binder cement mix to reduce the amount of standing water.** Water that does not cover a nickel after an hour is in tolerance.
3. Florida Courts will fill any existing cracks with **crack filler.** **We will then apply a 12" wide strip of fiberglass mesh covering the length of each existing crack.** *This will help the existing cracks from reappearing for a longer duration.*
4. Florida courts will resurface the existing court area using **Sport Master** specifications and materials with a **4 coat color system,** in the colors chosen by the client, (no additional charge for two-tone). **2 coats of Acrylic Resurfacer, fortified with sand,** will first be applied to prepare the court surface for the following color coats. This will be followed by the application of **2 coats of Color Concentrate, fortified with sand,** to provide uniformity & depth of color.
5. Florida Courts will **re-stripe all game lines with 1 coat of Stripe Right Primer and 1 coat of heavy bodied Textured T/C White Line Paint.**
6. Florida Courts agrees to provide all tools, materials, labor and supervision to complete the above work For a sum of **\$4,800.** Payment schedule as follows: 50% (\$2,400.) due before work is to begin, 50% (\$2,400.) due upon completion.
7. Client agrees to **provide water and electricity** for construction purposes.

WARRANTY:

Florida Courts guarantees workmanship and materials against defects for a period of one year, save normal wear and tear. This guarantee excludes normal wear and tear, abuse or neglect, including (but not limited to) acts of God or nature and/or any other conditions beyond our control; such as sub-base "settling", structural or shrinkage cracks, cracks of any kind, growth of mushrooms and or tree roots under the asphalt, fading of paint, hydrostatic pressure bubbles, intrusion of ants, grass or weeds, graffiti or other acts of vandalism, damage from roller blades, skateboards, bicycles, maintenance equipment and/or related fluids and/or other such implements and/or apparatus.

CONDITION OF SALE:

The Purchaser and Seller or its assigns agree to the purchase and sale of before described property on the following conditions:

- 1) That Purchaser will pay to Seller or its assigns the Total Contract Price in accordance with the terms set forth.
- 2) That if the Purchaser shall default in the payment of any installment or violate any of the provisions of this Contract the Seller or its assigns shall have the right to declare due the whole amount unpaid and without notice or demand, legal process, liability for trespass or damages, and without prejudice to other action, enter the premises where said property may be repossess and remove same.
- 3) That there are no agreements or warranties in connection with this transaction which are not expressly set forth in this Contract.
- 4) Buyer hereby assigns without recourse Florida Courts, Inc. the right and interests of the material and equipment in the above Contract and in the property described therein until paid in full.

IN WITNESS WHERE OF, the parties here to have executed this Contract by their proper officers or duly authorized agents on the day and year first above written.

The parties agree that in the event that payment is not made as provided herein, Contractor may terminate this contract, refuse to complete any work remaining pursuant to the contract, and any alternate proposals, amendments, changes, or modifications thereto, and sue for the payment due, plus any work performed by the contractor up until the date of termination, including a reasonable profit and overhead, court costs, attorney's fees (including attorney's fees incurred in arbitration and administrative proceedings and all state and federal actions and appeals), and interest at the rate of 1½% per month, 18% per year.

In the event of litigation of this contract, venue of same shall lie in Pasco County, Florida and the prevailing party shall be entitled to an award of reasonable attorney's fees and costs from the non-prevailing party. Insurance Certificates and Licenses Provided upon request *any changes or additions to standard coverage at additional cost.

PAGE 3 OF 3

*** Please note: a Start date cannot be scheduled without our receipt of a fully executed signed contract.**

ACCEPTED BY _____
CLIENT SIGNATURE

DATE ACCEPTED: _____

PRINT NAME _____

GREGORY A. VIRCHAU
PRESIDENT
FLORIDA COURTS, INC.

Please email or mail signed agreement to:

Email: floridacourts@verizon.net

**Florida Courts, Inc.
6820 Hudson Avenue
Hudson, Fl. 34667**

EXHIBIT 17C



1400 N.W. 13th Avenue
Pompano Beach, FL 33069

Job #24105

May 28, 2026

PROPOSAL

Billing:

Preserve at Wilderness Lakes
21320 Wilderness Lake Blvd
Land O Lakes, FL 34637

Job Address / Shipping:

Preserve at Wilderness Lakes
21320 Wilderness Lake Blvd
Land O Lakes, FL 34637

Contact: Tish Dobson
Telephone: 813-995-2437
E-mail: tdobson@vestapropertyservices.com

Dear Tish:

Thank you for taking the time to allow me an overview of your project needs. Tennis Holdings Acquisition, LLC dba Fast-Dry Courts proposes to provide the scope of work described as Resurface two (2) asphalt tennis courts, in one battery, measuring 120' x 120'. Saw cut and remove +/- 20 linear feet of isolated root intrusion in the northwest and southeast corners of the courts (per diagram) and patch with cold mix asphalt; fiberglass new-to-old asphalt seams; pressure clean to remove mildew and flood entire surface; patch low areas greater than +/- 1/8" and cracks wider than +/- 1/16"; **apply fiberglass membrane over entire court surface to help conceal existing cracking and retard future cracking**; apply **4-coat acrylic color system***, including 2 coats of acrylic resurfacer, 2 coats of acrylic court paint and playing lines to USTA specifications, with four (4) sets of blended pickleball lines (one set centered on each side of the tennis net of each court); repaint net posts (black) and install two (2) new Six Star II nets with center straps for the total cost of **\$22,970.00**. *NOTE: Owner is highly encouraged to install root barrier outside the court in the two (2) areas where root damage has occurred. A 1-year workmanship guarantee is offered with this work, and any guarantee in-line with cracks, hydrostatic pressure, and sub-base settling are excluded.*

**** Some competitors may advise applying 3-coat acrylic color system, utilizing only one (1) coat of acrylic resurfacer. An additional coat of acrylic resurfacer adds long term value and extends the life span of your court by filling cracks, providing a smoother surface, and better concealing corrective work, especially fiberglass membrane.***



www.fast-dry.com & www.10-s.com

National: (800) 432-2994 - Local: (954) 979-3111 - Fax: (954) 978-8479
CONSTRUCTION <> RESURFACING <> MAINTENANCE <> SUPPLY



A basic approach to resurfacing your court would be to simply apply either of the scopes listed above. However, here at FDC, we approach each job with the intent of adding value to our customers. After evaluating the court and the number of cracks that are visible, **we highly recommend that you also apply 1 coat of Laykold's Basecoat, an acrylic based emulsion blended with fibers and fillers, and mixed with Portland cement and sand, to use for smoothing rough pavements and filling in cracks, thus adding value.** This application is **\$4,900.00** in addition to the scope above, and it will help extend the lifespan of your court. *A 1-year workmanship guarantee is offered with this work, and any guarantee in-line with cracks, hydrostatic pressure, and sub-base settling are excluded.*

BASKETBALL

Resurface one (1) asphalt basketball court measuring 42' x 50'. Pressure clean to remove mildew and flood entire surface; patch low areas greater than +/- 1/8" and cracks wider than +/- 1/16"; **apply 4-coat acrylic color system**, including 2 coats of acrylic resurfacer, 2 coats of acrylic court paint and high school regulation basketball playing lines for the total cost of **\$5,700.00**.

A basic approach to resurfacing your court would be to simply apply the scope listed above. However, here at FDC, we approach each job with the intent of adding value to our customers. After evaluating the court and the number of cracks that are visible, **we recommend that you also apply a fiberglass membrane over entire asphalt surface to help conceal existing cracking and retard future cracking, thus adding value.** This application will also include an additional tack coat of acrylic resurfacer. This application is **\$1,600.00** in addition to the scope above, and it will help extend the lifespan of your court. In support, most resurfacing jobs are scoped this way. Should you wish, we will replace one (1) backboard with a new and more modern First Team 36" x 60" acrylic backboard with backboard braces and clamps, and heavy-duty flex rim for the additional cost of **\$2,995.00**.

Fast-Dry Courts has a proven 46-year track record of exceeding customer expectations. As a family-owned and operated company, we have completed over 16,000 projects with professionalism, quality, and performance. Our commitment to quality and professionalism has led the American Sports Builders Association (ASBA) to recognize Fast-Dry Courts for excellence in tennis court construction for an unprecedented 28 years. It also is what allowed us to become the official contractor of the Miami Open, since its move to Hard Rock Stadium in 2019. Furthermore, over 69% of our projects last year came from existing customers or referrals. Fast-Dry Courts is a licensed General Contractor, bondable and insured up to \$3,000,000.00, with all Project Managers having at least 18 years of experience.

Should you wish to move forward, a formal agreement and a deposit will be required prior to job scheduling, material ordering, and commencement. This proposal reflects preliminary budget estimates only and is valid for thirty (30) days unless extended in writing by Fast-Dry Courts. Terms are subject to change pending final design, engineering, and an executed agreement. If you have any further questions, please call me at (800) 432-2994.

Sincerely,

Fast-Dry Courts
Gerry Montovani
Account Executive

www.fast-dry.com & www.10-s.com

National: (800) 432-2994 - Local: (954) 979-3111 - Fax: (954) 978-8479
CONSTRUCTION <> RESURFACING <> MAINTENANCE <> SUPPLY

EXHIBIT 17D



QUOTE #775

SENT ON:

Jun 24, 2026

RECIPIENT:

Wilderness Lake Preserve

21320 Wilderness Lake Boulevard
Land O' Lakes, Florida 34637

SENDER:

Coastal Courts

2164 Platinum Road
Unit B
Apopka, Florida 32703

Phone: 407-822-9955

Email: estimating@coastalcourts.com

Website: www.coastalcourts.com

Product/Service	Description	Qty.	Unit Price	Total
Resurface double tennis court	<ul style="list-style-type: none"> - Power wash and/or machine sand the court(s) to eliminate dirt, mildew, minor imperfections, and raised crack edges. - Saw cut and remove approximately 20 square feet of damaged asphalt due to root intrusion. Patch with asphalt and compact. - Clean out the wider structural cracks and fill any cracks exceeding 1/16th of an inch with an acrylic patch mix. - Flood the court(s) and patch all areas retaining water to a tolerance of 1/8 inch after one hour of drainage. - Squeegee one coat of sand-filled acrylic resurfacer over the entire surface. - Squeegee two coats of sand-filled acrylic color over the entire surface, with colors to be selected. - Stripe 2ea tennis courts, ensuring all game lines are 2 inches wide, utilizing textured line paint in accordance with ASBA standards. - Stripe 4ea pickleball courts, all game lines will be 2" wide, using textured line paint according to ASBA regulations. Customer must use portable pickleball nets with this layout. - Hang 2ea new signature tennis net double top: 3.5mm braided w/ top 7 rows doubled, double-layered 51oz vinyl white head band. 	1	\$19,736.00	\$19,736.00



QUOTE #775

SENT ON:

Jun 24, 2026

Product/Service	Description	Qty.	Unit Price	Total
				Not included
Fiberglass Overlay option	Furnish and install 1.8oz fiberglass membrane over the entire court surface. This will create a layer over the existing surface preventing the return premature cracks. *Additional coat of resurfacer is included. Fiberglass mesh is a woven fabric made from glass fibers that provides high tensile strength and flexibility, making it ideal for reinforcing tennis court surfaces	1	\$7,800.00	\$7,800.00

Total **\$19,736.00**

Images

View online <https://l.jbbr.io/TAs81fH>

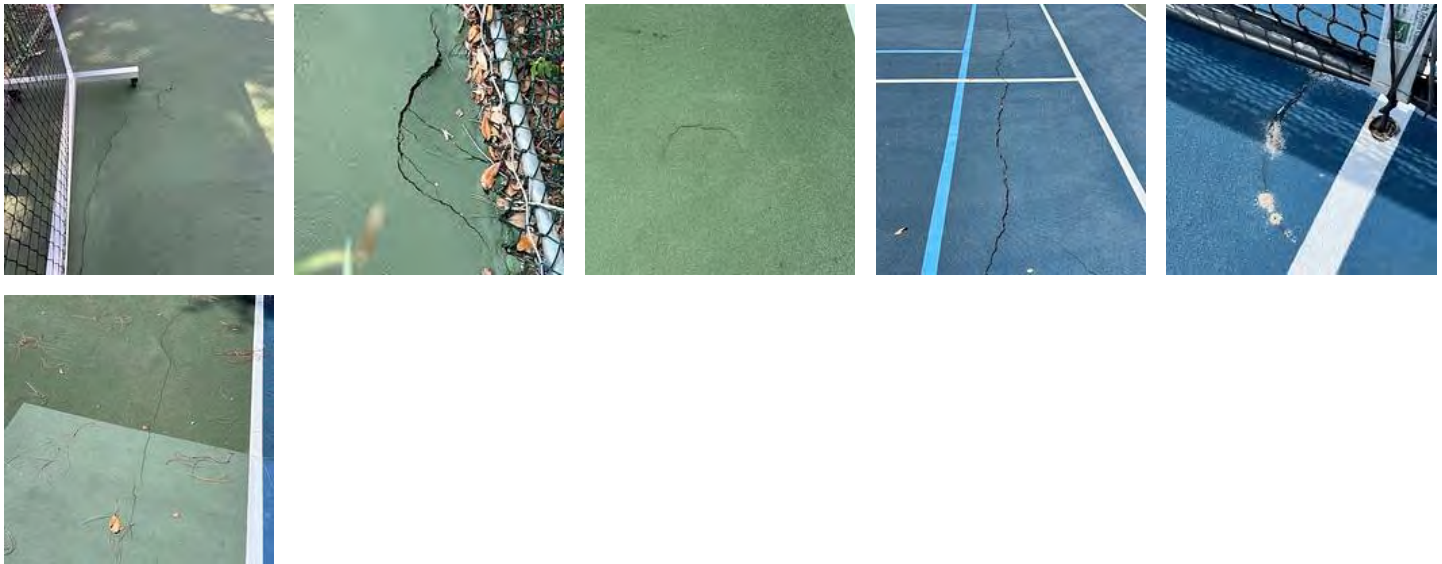



QUOTE #775

SENT ON:

Jun 24, 2026

Reviews

Catherine Tagliareni



I cannot say enough great things about Coastal Courts. From start to finish, every single person I worked with was professional, kind, knowledgeable, and incredibly thorough. They were accommodating throughout the entire process and always took the time to make sure every detail was handled correctly. Their pricing was lower than their competitors', and the quality of their work exceeded my expectations. They didn't just improve my court — they made it look and perform better than when it was originally installed. The attention to detail and pr...

Tee Wells



Very responsive and very professional. Outstanding work. Really helped with strategizing what I need and what I didn't need.

Rebecca Rutledge



I am a Property Manager and used Coastal Courts to redo a tennis court in one of my Associations. They were AMAZING!! The end result brought back life to years of deterioration, and the entire community and Board of Directors is very pleased with how it turned out. Rob and Nick are wonderful to work with. Midway through the project we had to adjust the plan, and they came in with their expertise and guidance that really did make a huge difference. I HIGHLY recommend this company and will be using them in the future for any other projects I may ...

CONDITION OF SALE:

- This quote is valid for the next 30 days, after which values may be subject to change.
- Permits are not included.
- All labor is open shop, court must be accessible with heavy equipment, customer must provide a water source to flood court(s) and mix materials.
- Work can only be completed under acceptable weather conditions. Customer must turn off all sprinklers systems that may cause water to fall upon court(s).
- Coastal Courts is not responsible for damage to vegetation, driveways, sidewalks, curbs, or irrigation systems.
- Coastal Courts guarantees workmanship and material for one year after completion date. This guarantee excludes normal wear and tear, physical abuse or neglect, and any other condition beyond our control such as subbase settling, structural cracks, hydrostatic pressure, water vapor pressure bubbles, and intrusion of weeds or insects. Please note: As asphalt sport court age and weathers, it oxidizes, shrinks, and hardens, making it less flexible and more prone for cracks to reappear and new cracks to form. Coastal Courts does not warranty any new appearing or existing cracks reappearing. Cracks develop on sports courts for several reasons, below are the most common:
 - * Asphalt expands and contracts with temperature fluctuations, causing new cracks to appear and old cracks to reappear, most common in colder months.
 - * Loss of oils in asphalt causing the asphalt to dry out and be less flexible
 - * Changes in base stability, causing a crack reflecting through the surface.

PAYMENT TERMS

1. New Construction and Reconstruction Projects:

A 35% deposit is required to secure materials and schedule the project. A 35% progress payment will be due upon substantial completion of the asphalt or concrete and or fence phase, and the remaining 30% final payment will be due upon project completion.

2. Resurfacing Projects:

A 50% deposit is required prior to scheduling and mobilization. The remaining 50% balance will be due upon completion of



QUOTE #775

SENT ON:

Jun 24, 2026

the resurfacing work.

Please Note: All deposits are non-refundable once materials have been ordered or work has commenced. Payment must be made according to the schedule above to avoid project delays.

Signature: _____ **Date:** _____

EXHIBIT 17E



FLORIDA COURTS, INC.
6820 HUDSON AVE.
HUDSON, FL 34667
727-861-0004

www.floridacourtsinc.com

PROPOSAL A
PAGE 1 OF 3

AGREEMENT

DATE: 6/20/26

CONTACT: Tish Dobson (General Manager) ph# 813-995-2437
Email: manager@wplodge.com

LOCATION: Wilderness Lake Preserve - 21320 Wilderness Lake Blvd. - Land O Lakes, FL 34637

CONDITIONS: Resurface the 2 Tennis Court / 4 Pickleball Court & Sitting Area surface with a 5 coat system. Extensive crack repairs. (a 5 coat system will be needed to cover all the repairs).

1. Florida Courts will first **pressure wash any mildew off** the courts & sitting area to provide a proper base for adhesion of resurfacing materials.
2. Florida Courts will **flood the courts** and check for puddles where standing water covers 1/8" in depth (thickness of a nickel) after the surface has been able to dry, under sunny conditions, for 1 hour. We will then **patch these areas with Acrylic Patch Binder cement mix to reduce the amount of standing water.** Water that does not cover a nickel after an hour is in tolerance.
3. Florida Courts will fill any existing cracks with **crack filler. There is a total of 450 LN' of crack repair. We will apply Heavy Duty Crack Tape followed by a 12" wide strip of Fiberglass mesh to cover 200 LN' of the worst, strongest cracks (this should keep the worst cracks from wrinkling the fiberglass.) We will then apply just a 12" wide strip of fiberglass mesh covering the length of the rest of the cracks (250 LN').**
4. Florida courts will resurface the existing 2 court area & sitting area, using **Sport Master** specifications and materials, with a **5 coat color system**, in the colors chosen by the client, (no additional charge for two-tone). **3 coats of Acrylic Resurfacer, fortified with sand**, will first be applied to prepare the court surface for the following color coats. This will be followed by the application of **2 coats of Color Concentrate, fortified with sand**, to provide uniformity & depth of color.
5. Florida Courts will **re-stripe all tennis game lines with 1 coat of Stripe Right Primer and 1 coat of heavy bodied Textured T/C White Line Paint. We will re line 4 sets of pickleball game lines in the clients choice of color.** Florida Courts **will re-paint existing tennis net posts.**
6. Florida Courts agrees to provide all tools, materials, labor and supervision to complete the above work For a sum of **\$46,000.** Payment schedule as follows: 50% (\$23,000.) due before work is to begin, 50% (\$23,000.) due upon completion.
7. Client agrees to **provide water and electricity** for construction purposes.

WARRANTY:

Florida Courts guarantees workmanship and materials against defects for a period of one year, save normal wear and tear. This guarantee excludes normal wear and tear, pre existing structural damage, abuse or neglect, including (but not limited to) acts of God or nature and/or any other conditions beyond our control; such as sub-base "settling", structural or shrinkage cracks, cracks of any kind, growth of mushrooms and or tree roots under the asphalt, fading of paint, hydrostatic pressure bubbles, intrusion of ants, grass or weeds, graffiti or other acts of vandalism, damage from roller blades, skateboards, bicycles, maintenance equipment and/or related fluids and/or other such implements and/or apparatus.

CONDITION OF SALE:

The Purchaser and Seller or its assigns agree to the purchase and sale of before described property on the following conditions:

- 1) That Purchaser will pay to Seller or its assigns the Total Contract Price in accordance with the terms set forth.
- 2) That if the Purchaser shall default in the payment of any installment or violate any of the provisions of this Contract the Seller or its assigns shall have the right to declare due the whole amount unpaid and without notice or demand, legal process, liability for trespass or damages, and without prejudice to other action, enter the premises where said property may be repossess and remove same.
- 3) That there are no agreements or warranties in connection with this transaction which are not expressly set forth in this Contract.
- 4) Buyer hereby assigns without recourse Florida Courts, Inc. the right and interests of the material and equipment in the above Contract and in the property described therein until paid in full.

IN WITNESS WHERE OF, the parties here to have executed this Contract by their proper officers or duly authorized agents on the day and year first above written.

The parties agree that in the event that payment is not made as provided herein, Contractor may terminate this contract, refuse to complete any work remaining pursuant to the contract, and any alternate proposals, amendments, changes, or modifications thereto, and sue for the payment due, plus any work performed by the contractor up until the date of termination, including a reasonable profit and overhead, court costs, attorney's fees (including attorney's fees incurred in arbitration and administrative proceedings and all state and federal actions and appeals), and interest at the rate of 1½% per month, 18% per year.

In the event of litigation of this contract, venue of same shall lie in Pasco County, Florida and the prevailing party shall be entitled to an award of reasonable attorney's fees and costs from the non-prevailing party. Insurance Certificates and Licenses Provided upon request *any changes or additions to standard coverage at additional cost.

*** Please note: a Start date cannot be scheduled without our receipt of a fully executed signed contract.**

ACCEPTED BY _____
CLIENT SIGNATURE

DATE ACCEPTED: _____

PRINT NAME _____

GREGORY A. VIRCHAU
PRESIDENT
FLORIDA COURTS, INC.

Please email or mail signed agreement to:

Email: floridacourts@verizon.net

**Florida Courts, Inc.
6820 Hudson Avenue
Hudson, Fl. 34667**